

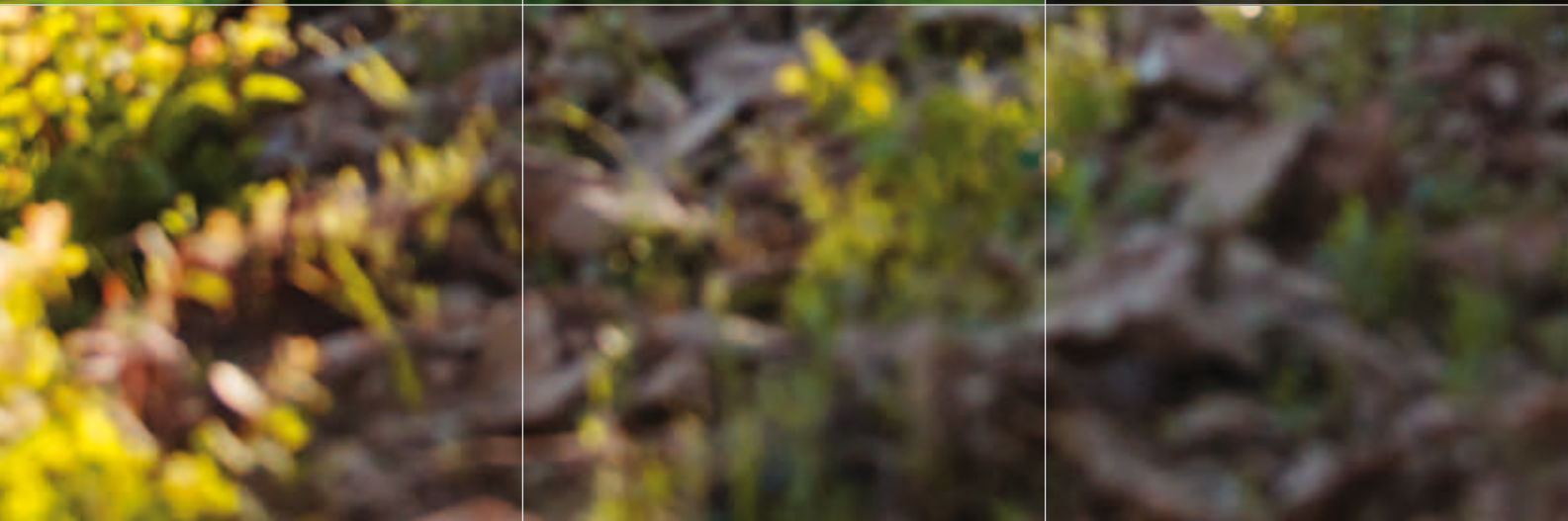

2013
BICYCLES

cannondale



CONTENT

MOUNTAIN

OVERMOUNTAIN	XC FULL SUSPENSION	XC RACE	TRAILS HARDTAILS
CLAYMORE 08	LEFTY / HEADSHOK 24	F29 CARBON 38	TRAIL SL 29ER 45
JEKYLL MX 10	SCALPEL 29ER CARBON 28	F29 42	TRAIL SL 47
JEKYLL CARBON 12	SCALPEL 29ER 32	F26 CARBON 43	
JEKYLL 13	RZ120 XLR 33	F26 44	
TRIGGER 29ER 16	RZ120 35		
TRIGGER CARBON 20	SCALPEL RACE 36		

ROAD

ELITE ROAD	PERFORMANCE ROAD	TRIATHLON / TIME TRIAL	CYCLOCROSS
SUPERSIX EVO 52	SYNAPSE HI-MOD 64	SLICE RS 70	SUPERX 75
SUPERSIX 58	SYNAPSE CARBON 67	SLICE 73	CAADX 78
CAAD10 60	SYNAPSE 69		
CAAD8 62			

URBAN

E-SERIES	STREET	RECREATION
E-SERIES WOMEN'S 82	BAD BOY 86	QUICK SPEED 92
E-SERIES MEN'S 83	BAD GIRL 90	QUICK CX 96
	HOOLIGAN 91	TESORO 98

WOMEN'S

OVERMOUNTAIN	TRAIL HARDTAILS	ELITE ROAD	PERFORMANCE ROAD
SCARLET 104	TRAIL SL 29ER WOMEN'S 108	SUPERSIX EVO WOMEN'S 110	SYNAPSE CARBON WOMEN'S 114
	TRAIL SL WOMEN'S 108	SUPERSIX WOMEN'S 112	SYNAPSE WOMEN'S 115
XC FULLSUSPENSION		CAAD10 WOMEN'S 113	
LEXI 106			TRIATHLON / TIME TRIAL
			SLICE WOMEN'S 116

KID'S

RACE 118
TRAIL 120

HELMETS

ROAD	MOUNTAIN
CYPHER 122	RYKER 123
TERAMO 123	

INFO

SPECIFICATIONS 124	DISTRIBUTORS 141
GEOMETRIES 134	





BENVENUTI NEL TEAM CANNONDALE.

> Siamo un gruppo di ciclisti, atleti, ingegneri, innovatori che passano le loro giornate concentrati su un solo obiettivo – creare la bici perfetta...per te.

Per ottenere questo risultato pedaliamo le nostre bici ogni giorno. Gareggiamo. Discutiamo con i nostri compagni di uscita, da quelli della sgambata del mercoledì sera a quelli che gareggiano al Tour o alla Megavalanche, fino a quelli fermi al semaforo durante gli spostamenti mattutini. Ascoltiamo, modifichiamo, proviamo e pedaliamo di nuovo.

Questo processo, questa passione per il ciclismo che è il cuore della cultura Cannondale, è il motore che ci spinge. È la fonte di ispirazione per incredibili nuove bici come la SuperSix EVO Nano – il telaio da corsa più avanzato mai prodotto, la Trigger – il nuovissimo membro della famiglia OverMountain, la lama affilata Slice RS da crono, le Quick Speed e Quick CX perfette machine per stare in forma e muoversi velocemente.

Quindi, sia che tu sia un garista di alto livello, un duro e appassionato mountain biker, un pendolare o un cacciatore di sentieri nel weekend, noi abbiamo la bici disegnata apposta per te – your perfect ride.

Benvenuto nel Team.





MOUNTAIN

CANNONDALE MOUNTAIN —

Nel difficile caos dello European Enduro Series, nella competizione a tutto gas del World Cup XC oppure sul veloce singletrack tecnico proprio dietro la nostra sede centrale nel Connecticut, la passione per i percorsi nodosi e fangosi ci spinge a creare mountain bike perfette per i tuoi percorsi e per la tua anima.



> OVERMOUNTAIN

CLAYMORE (BIG MOUNTAIN)

JEKYLL (ALL-MOUNTAIN)

JEKYLL MX (ENDURO)

TRIGGER 29'ER (CROSS-MOUNTAIN)

TRIGGER (CROSS-MOUNTAIN)

Non convenzionale, rompe ogni limite, a doppia corsa, doppia geometria, ridefinisce il concetto di "all" nel ciclismo all-mountain.

> CROSS COUNTRY

SCALPEL 29'ER CARBON

SCALPEL 29'ER

RZ ONE TWENTY

Leggere, reattive e versatili biciclette con doppia sospensione a media escursione. Studiate per la guida veloce su trail.

> XC RACE

SCALPEL RACE

F29 CARBON

F29

F26 CARBON

F26

Mountain bike ultra-leggere, orientate alla competizione per ciclisti che cercano il massimo dell'efficienza e della velocità.



> TRAIL HARDTAILS

TRAIL SL 29'ER

TRAIL SL

Mountain bike leggera, durature, ad alte prestazioni per un riding su trail a tutto tondo.



OVERMOUNTAIN

RIDEFINISCE IL CONCETTO DI "ALL" NELLA PRATICA DELL'ALL-MOUNTAIN

Che scegliate la Big-Mountain Claymore, le All-Mountain Jekyll e Scarlet, o le Cross-Mountain Trigger e Trigger 29'er, i leggeri telai OverMountain, robusti e ultra-reattivi con la possibilità di cambiare in corsa l'escursione, la risposta degli ammortizzatori e la geometria vi consentono di conquistare la montagna in ogni suo aspetto, meglio che mai.



> DOPPIO AMMORTIZZATORE FOX DYAD RT2

L'unico vero ammortizzatore 2-in-1 al mondo. Nascosti all'interno del DYAD ci sono due diversi ammortizzatori: uno ad escursione corta (Elevate) e uno ad escursione lunga (Flow), che consentono di cambiare al volo l'escursione, la curva di compressione e la geometria per le migliori prestazioni possibili attraverso il più ampio spettro di terreni.

ELEVATE: Come montare un ammortizzatore ad corta escursione sulla vostra bike. Escursione più corta fortemente progressiva che fornisce una grande trazione e la massima efficienza di pedalata. Idraulica dedicata, ottimizzata per la salita e per pedalare veloce.

FLOW: Come passare ad un ammortizzatore a molla a lunga escursione. Escursione più lunga, con progressione lineare che offre una sospensione morbida prevedibile per discese ad alta velocità. Idraulica dedicata, ottimizzata per il massimo della morbidezza e del controllo.

> GEOMETRIA A DOPPIA PERSONALITÀ

Le diverse parti di un percorso richiedono geometrie differenti. Le arrampicate e i terreni tecnicamente impegnativi richiedono una manovrabilità più agile e una posizione efficiente in sella, mentre le discese a tutta richiedono un baricentro più basso e una guida più stabile. Passando tra le due modalità di escursione dell'ammortizzatore DYAD la geometria della bicicletta cambia di conseguenza grazie a un diverso valore di sag.

ELEVATE: Nell'impostazione ad escursione più corta, il sag è inferiore, quindi il movimento centrale è più alto e gli angoli di sterzo e piantone sono più verticali, per una maggiore maneggevolezza e un'arrampicata più potente.

FLOW: Nell'impostazione ad escursione più lunga, l'ammortizzatore aumenta il sag e il movimento centrale ribassato e gli angoli più morbidi donano una grande stabilità alle alte velocità e in curva.

> ECS-TC

Enhanced Center-Stiffness, Torsion Control – L'ECS-TC è la chiave della guida incredibilmente reattiva dell'OverMountain. Una bicicletta è rigida solo quanto lo sono le sue parti più deboli, quindi abbiamo creato il sistema ECS-TC per rimuovere la flessione e il gioco dai link e dai perni che collegano il triangolo anteriore e lo snodo principale. Eliminando le flessioni indesiderate ne risulta una bici che risponde istantaneamente agli input da parte del rider per il massimo delle prestazioni e del controllo.

ASSI PASSANTI DA 15MM: Avendo il link dell'ammortizzatore e lo snodo principale bloccati direttamente su assi passanti oversize, l'asse stesso diventa un elemento strutturale per la prevenzione di una flessione torcente.

CUSCINETTI POSIZIONATI A DISTANZA: Tutti i link presentano i cuscinetti posizionati il più distanti possibile, per massimizzare la rigidità.

DOPPI CUSCINETTI SUGLI SNODI DEL CARRO: Collocando due cuscinetti fianco a fianco nei perni posteriori si elimina il gioco torcente nella sede dei cuscinetti per una reattività immediata.



BIG-MOUNTAIN > CLAYMORE

Rider amano i colpi forti e i grossi salti ma che desiderano andare oltre i semplici bike park e risalite furgonate.

TRAVEL: 180 / 110mm [R], 180mm [F]



ENDURO > JEKYLL MX

Racer Enduro/SuperD e duri rider all-mountain che hanno bisogno di avanzate possibilità discesistiche bilanciate con la capacità di salire fino in cima.

TRAVEL: 150 / 90mm [R], 160mm [F]



ALL-MOUNTAIN > JEKYLL

Per rider tecnicamente aggressivi che amano le arrampicate rapide e le discese ancora più veloci su una vasta gamma di tipologie di terreno.

TRAVEL: 150 / 90mm [R], 160mm [F]



CROSS-MOUNTAIN > TRIGGER 29'ER

Per veloci e versatili trail riders che cercano la massima velocità su difficili e tecnici terreni.

TRAVEL: 130 / 80mm [R], 130mm [F]



CROSS-MOUNTAIN > TRIGGER

Rider veloci e fluidi, che cercano una miscela agile di velocità cross-country e capacità all-mountain.

TRAVEL: 120 / 70mm [R], 130mm [F]



CLAYMORE

> SIATE LA VOSTRA SEGGIOVIA.

La Big-Mountain Claymore porta una versatilità e una guidabilità senza precedenti nella categoria long-travel. Azionando una levetta si trasforma da un cavallo da battaglia con corsa da 180 mm in un'efficiente trail bike per climbing con corsa di 110 mm. La scelta perfetta per i bike park, le risalite furgonate e per sentieri di esplorazione che nessuna seggiovia servirà mai.



CLAYMORE 1

FRAME	CLAYMORE, 180/110MM, SMARTFORMED ALLOY
SUSPENSION F/R	FOX 36 TALAS R 180MM, 20QR / FOX DYAD RT2 180/110MM
WHEELS	SUN RINGLE CHARGER PRO

TIRES	SCHWALBE HANS DAMPF TRAILSTAR, 2.35* TUBELESS READY
CRANKS	SRAM S1400, BB30, 36/22
DERAILLEUR R/F	SHIMANO XT SHADOW + / SRAM X7

MAGNESIUM WHITE, GLOSS (WHT)

SHIFTERS	SHIMANO XT
BRAKES	SHIMANO XT TRAIL, 203/180MM
SIZES	S, M, L

> REGOLABILITÀ SUPREMA

L'attacco dell'ammortizzatore a 2 posizioni vi consente di scegliere l'altezza iniziale del movimento centrale e gli angoli per adattarsi al vostro stile di guida e al terreno, in più la doppia modalità del DYAD, Elevate (110mm) e Flow (180mm), regola ulteriormente la geometria, l'escursione e la risposta degli ammortizzatori in corsa. È come avere due bike completamente differenti in una.

> ASSI PASSANTI ECS-TC

Una delle motivazioni chiave per l'incredibile reattività della Claymore è il sistema ad asse passante ECS-TC (Enhanced Center-Stiffness – Torsion Control). Il link dell'ammortizzatore e il forcellone sono connessi direttamente a massicci assi passanti da 15mm, eliminando così le flessioni e permettendo alla bici di rispondere istantaneamente ai comandi.

> DOPPI CUSCINETTI

Per incrementare ulteriormente la rigidità e la risposta, Claymore viene dotata di cuscinetti double-stacked sui perni posteriori. Collocando due cuscinetti fianco a fianco eliminiamo il gioco torsionale nei cuscinetti, irrigidendo il braccio oscillante e migliorando la sensibilità e il controllo.



CLAYMORE 2

FRAME	CLAYMORE, 180/110MM, SMARTFORMED ALLOY
SUSPENSION F/R	FOX 36 VAN R, 180MM, 20QR / FOX DYAD RT2 180/110MM
WHEELS	WTB ST I23 TCS W/ FORMULA HUBS

TIRES	WTB VIGILANTE TCS, 2.3", TUBELESS READY
CRANKS	TRUVATIV RUKTION, 34
DERAILLEUR R/F	SRAM X7 / X7

JET BLACK, GLOSS (BLK)

SHIFTERS	SRAM X7 / X7
BRAKES	AVID ELIXIR 5, 200/180MM
SIZES	S, M, L

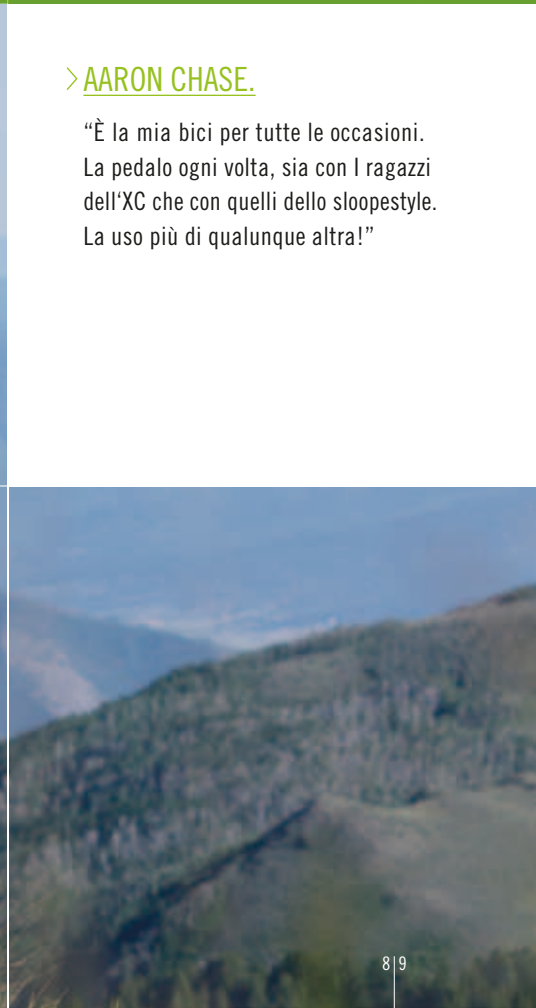

> AARON CHASE.

“È la mia bici per tutte le occasioni. La pedalo ogni volta, sia con i ragazzi dell'XC che con quelli dello sloopestyle. La uso più di qualunque altra!”

JEKYLL MX

> L'ARMA PER LA COMPETIZIONE ENDURO.

Se il vostro stile di guida e di gara mescola climbing e pedalata con tonnellate di discese a tutta birra, la Jekyll MX è la bici che fa per voi. Ispirata dalle configurazioni con cui corre il team OverMountain, la MX prende la reattività istantanea e la versatilità dalla doppia natura della Jekyll e la rende ancora più abile in DH con una specifica completa pronta per l'Enduro.



JEKYLL MX

FRAME	JEKYLL, 150/90MM, SMARTFORMED ALLOY
SUSPENSION F/R	FOX 36 FLOAT R, 160MM, 20QR / FOX DYAD RT2 150/90MM
WHEELS	WTB STRYKER TCS 123

TIRES	WTB VIGILANTE FRONT/ MOTO REAR, TCS, 2.3 , TUBELESS READY
CRANKS	SRAM S1400, BB30, 36/22
DERAILLEUR R/F	SHIMANO XT SHADOW + / SRAM X7

JET BLACK, GLOSS (BLK)

SHIFTERS	SHIMANO XT
BRAKES	SHIMANO XT TRAIL, 180/180MM
SIZES	S, M, L, XL

> DYAD RT2

I rider OverMountain utilizzano la modalità Elevate del DYAD per più che il semplice climbing. Passano a lei per efficienti partenze veloci, per andare a tavoletta abbassandosi e guadagnare tempo sulle sezioni di pedalata. Poi torna al FLOW per una discesa fluida a tutta birra.

> SPECIFICA ROBUSTA DA ENDURO

La specifica parti ispirata al team OverMountain include una robusta forcella FOX 36 con asse passante da 20mm, ruote resistenti WTB Stryker, guidacatena MRP e reggisella dropper RockShox così la MX è pronta a tutto.

> TELAIO IN LEGA SMARTFORMED

SmartForming è un mix sofisticato di idroformatura, sagomatura meccanica, stratificazione progressiva, saldatura liscia a doppio passaggio, forgiatura 3D e trattamento termico in piccoli lotti (un modo complicato di dire che è la struttura in alluminio più aggressiva del pianeta).



› BEN CRUZ.

“È veramente rigida. È precisa e controllabile, anche sui terreni più brutali.”

JEKYLL

> PEDALA OVUNQUE. CAVALCA QUALSIASI OSTACOLO.

La Jekyll è la All-Mountain più versatile in circolazione. Con la sua escursione regolabile in corsa da 90 mm a 150 mm e la geometria che cambia trasformandosi da agile trail-bike a stabile discesista muovendo una levetta, è la macchina perfetta per rider all-mountain tecnicamente aggressivi che scalano in fretta, ma che desiderano scendere persino più velocemente lungo tutti i terreni montani.



> DYAD RT2

La stessa tecnologia DYAD di due ammortizzatori in uno che troviamo nelle altre bici OverMountain, ma con corsa dell'ammortizzatore, volume delle camere e circuiti di smorzamento ottimizzati per la modalità Elevated 90 mm e Flow 150 mm della Jekyll.



> SISTEMA ECS-TC

Gli assi passanti da 15 mm in corrispondenza del link ammortizzatore e dello snodo principale, insieme ai doppi cuscinetti nei perni dei forcelini posteriori eliminano la flessione e garantiscono una robustezza centrale senza eguali, per un controllo e una reattività totali.



> TELAI ROBUSTI E LEGGERI

Che sia il leggero e incredibilmente resistente carbonio BallisTec o l'insuperabile tecnologia in alluminio della nostra lega SmartFormed, i telai Jekyll offrono una combinazione di peso leggero, durabilità e rigidità che vi consentono di galleggiare sulle salite e bruciare le discese.



JEKYLL CARBON 1

FRAME	JEKYLL, 150/90MM, BALLISTEC HI-MOD CARBON
SUSPENSION F/R	FOX 34 TALAS FIT, KASHIMA, 160MM, 15QR / FOX DYAD RT2 150/90MM
WHEELS	REYNOLDS CARBON AM

TIRES	SCHWALBE HANS DAMPF TRAILSTAR, 2.35" TUBELESS READY
CRANKS	SRAM S2210, BB30, 36/22
DERAILLEUR R/F	SHIMANO XTR SHADOW + / SRAM X0

JET BLACK W/ MAGNESIUM WHITE AND BERSERKER GREEN ACCENTS, GLOSS (BLK)

SHIFTERS	SHIMANO XT
BRAKES	SHIMANO XTR TRAIL, 180/180MM
SIZES	S, M, L, XL



JEKYLL CARBON 2

FRAME	JEKYLL, 150/90MM, BALLISTEC HI-MOD CARBON
SUSPENSION F/R	FOX 34 TALAS CTD, 160MM, 15QR / FOX DYAD RT2 150/90MM
WHEELS	MAVIC CROSSTRAIL

JET BLACK, W/ NEARLY BLACK AND I LOVE GOLD ACCENTS (MATTE) (BBQ)

TIRES	SCHWALBE HANS DAMPF TRAILSTAR, 2.35" TUBELESS READY
CRANKS	SRAM S2210, BB30, 36/22
DERAILLEUR R/F	SRAM X9 TYPE 2 / X7

ULTRA BLUE W/ MAGNESIUM WHITE AND 40 ORANGE ACCENTS, GLOSS (BLU)

SHIFTERS	SRAM X9
BRAKES	MAGURA MT4, 180/180MM
SIZES	S, M, L, XL



JEKYLL 3

FRAME	JEKYLL, 150/90MM, SMARTFORMED ALLOY
SUSPENSION F/R	FOX 32 FLOAT CTD, 150MM, 15QR / FOX DYAD RT2 150/90MM
WHEELS	SHIMANO MT68

TIRES	WTB VIGILANTE FRONT/ MOTO REAR, TCS, 2.3 , TUBELESS READY
CRANKS	SRAM S1400, BB30, 36/22
DERAILLEUR R/F	SHIMANO XT SHADOW + / SRAM X7

JET BLACK, MATTE (BBQ)

SHIFTERS	SHIMANO SLX
BRAKES	MAGURA MT2 W/BAT, 180/180MM
SIZES	S, M, L, XL



JEKYLL 4

FRAME	JEKYLL, 150MM, SMARTFORMED ALLOY
SUSPENSION F/R	ROCKSHOX SEKTOR TK, 150MM, 15QR / XFUSION P1-RL 150MM
WHEELS	WTB ST 119 TCS W/ FORMULA HUBS

TIRES	WTB VIGILANTE FRONT/ MOTO REAR, TCS, 2.3", TUBELESS READY
CRANKS	SRAM S1000, BB30, 44/33/22
DERAILLEUR R/F	SRAM X7/ SRAM X7

MAGNESIUM WHITE, GLOSS (WHT)

SHIFTERS	SRAM X5
BRAKES	MAGURA MT2, 180/180MM
SIZES	S, M, L, XL



> MARK WEIR.

“Sono più veloce ovunque sulla mia Jekyll, sia in salita che in discesa. È incredibile. È decisamente la bici costruita per il tipo di percorsi gi oggi.”

TRIGGER 29ER

> OVERMOUNTAIN. OVER ANYTHING.

Salire con una agile race-bike ultra-efficiente con escursione di 80 mm, scendere con una inarrestabile e precisa macchina da trail con ruote grosse e escursione di 130 mm. La Trigger 29'er combina le personalità doppia escursione/doppia personalità della OverMountain con la trascinante inerzia delle "big wheel" che travolge qualsiasi cosa. È un match perfetto.



> DYAD RT2

Mentre altre 29'er a escursione lunga sono forzate ad accettare un compromesso tra le necessità di salire e di scendere, l'ammortizzatore DYAD della Trigger 29'er le consente di modificare l'escursione, lo smorzamento e la geometria per adattarsi al terreno, in modo da risultare nettamente vincente sia nel climbing che nelle discese.



> SISTEMA ECS-TC

La rigidità è persino più importante sulle 29'er. La Trigger 29'er ha gli assi passanti ECS-TC oversize, bloccati sullo snodo principale e i pivot del ammortizzatore, e doppi cuscinetti in corrispondenza di ciascuna estremità dei foderi bassi per ridurre radicalmente la flessione e il gioco per il massimo in materia di reattività e controllo.



> GEOMETRIA IDEALE 29'ER

Il tubo reggisella curvato consente alla Trigger 29'er di presentare foderi alti incredibilmente corti per una manovrabilità e un'agilità fulminea, pur continuando ad ottenere un'escursione piena di 130 mm in modalità Flow.

LEFTY
 HYBRID



TRIGGER 29ER 1

FRAME	TRIGGER 29'ER, 130/80MM, SMARTFORMED ALLOY
SUSPENSION F/R	SUPERMAX CARBON PBR 130 29 / FOX DYAD RT2 130/80MM
WHEELS	STAN'S ZTR CREST 29'ER W/ LEFTY & SHIMANO HUBS

TIRES	SCHWALBE HANS DAMPE, 2.35" TUBELESS READY
CRANKS	SRAM S1400, BB30, 36/22 W/GUARD
DERAILLEUR R/F	SHIMANO XT SHADOW +/- SRAM X7

JET BLACK, MATTE (BBQ)

SHIFTERS	SHIMANO XT
BRAKES	SHIMANO XT TRAIL, 180/160MM
SIZES	S, M, L, X



TRIGGER 29ER 2

FRAME	TRIGGER 29"ER, 130/80MM, SMARTFORMED ALLOY
SUSPENSION F/R	FOX 34 FLOAT CTD FIT 29 130MM, 15QR / FOX DYAD RT2 130/80MM
WHEELS	WTB FREQUENCY RACE I23 29"ER TCS W/ FORMULA HUBS

TIRES	SCHWALBE HANS DAMPF, 2.35" TUBELESS READY
CRANKS	SRAM S1000, BB30, 36/22 W/GUARD
DERAILLEUR R/F	SRAM X9 TYPE 2/ X7

JET BLACK, MATTE (BBQ)

SHIFTERS	SRAM X7
BRAKES	MAGURA MT2 W/BAT, 180/160MM
SIZES	S, M, L, X



TRIGGER 29ER 3

FRAME	TRIGGER 29"ER, 130, SMARTFORMED ALLOY
SUSPENSION F/R	ROCKSHOX REVELATION RL 29, 130MM, 15QR / XFUSION P1-RL 130MM
WHEELS	WTB ST I23 29"ER TCS W/ FORMULA HUBS

TIRES	WTB WOLVERINE TCS, 2.25" TUBELESS READY
CRANKS	SRAM S1000, BB30, 36/22 W/GUARD
DERAILLEUR R/F	SHIMANO XT / SRAM X7

MAGNESIUM WHITE W/ JET BLACK AND ULTRA BLUE ACCENTS, GLOSS (BLU)

SHIFTERS	SHIMANO SLX
BRAKES	MAGURA MT2, 180/160MM
SIZES	S, M, L, X



TRIGGER

> LA VELOCITÀ DEL CROSS-COUNTRY INCONTRA LA CAPACITÀ DELL'ALL-MOUNTAIN: PREMI IL GRILLETTO.

La Cross-Mountain TRIGGER spazza via il confine tra cross-country e all-mountain. Corsa più breve con una geometria più orientata al fast-trail, Trigger porta la migliore tecnologia OverMountain a rider fluidi e rapidi il cui stile e terreno richiede meno corsa e aggressività della Jekyll.



> DYAD RT2

Un ammortizzatore DYAD più piccolo offre gli stessi benefici "due in uno" e prestazioni della Claymore e Jekyll, ma a misura della Trigger. Elevate (70 mm) offre un'efficienza di bike da gara, mentre Flow (120 mm) offre una sensazione all-mountain più morbida.



> SISTEMA ECS-TC

Gli assi passanti da 15 mm, bloccati, in corrispondenza del link ammortizzatore e dello snodo principale eliminano la flessione e garantiscono una robustezza centrale senza eguali, per un controllo totale.

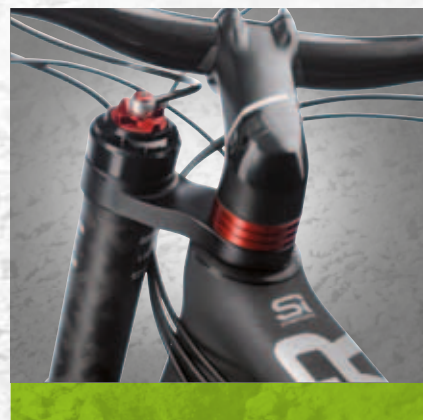

> SYSTEM INTEGRATION

Riusciamo ad ottenere incredibili risparmi di peso e la massima efficienza progettando componenti e telai che collaborano tra loro. La nostra forcella Lefty e lo stelo Si OPI offrono una rigidità insuperata e peso leggero per una bike con escursione lunga.



TRIGGER CARBON ULTIMATE

FRAME	TRIGGER, 120/70MM, BALLISTEC HI-MOD CARBON
SUSPENSION F/R	LEFTY CARBON XLR 130 26 / FOX DYAD RT2 120/70MM
WHEELS	ENVE COMPOSITES TWENTY6 AM W/LEFTY & DT SWISS 240

TIRES	SCHWALBE RACING RALPH EVO, 2.25" TUBELESS READY
CRANKS	CANNONDALE HOLLOWGRAM SI SL2, BB30, 38/24
DERAILLEUR R/F	SRAM XX / XO

EXPOSED CARBON W/ JET BLACK AND CHARCOAL GRAY ACCENTS (MATTE) (CRB)

SHIFTERS	SRAM XX
BRAKES	AVID XO CARBON, 180/160MM
SIZES	S, M, L, XL



TRIGGER CARBON 1

FRAME	TRIGGER, 120/70MM, BALLISTEC HI-MOD CARBON
SUSPENSION F/R	LEFTY CARBON XLR 130 26 / FOX DYAD RT2 120/70MM
WHEELS	REYNOLDS AM CARBON 26 W/ LEFTY

TIRES	SCHWALBE RACING RALPH EVO, 2.25" TUBELESS READY
CRANKS	SRAM S2210, BB30, 38/24 W/GUARD
DERAILLEUR R/F	SHIMANO XTR SHADOW+ / SRAM X0

EXPOSED CARBON W/ MAGNESIUM WHITE AND BERSERKER GREEN ACCENTS, GLOSS (BLK)

SHIFTERS	SHIMANO XT
BRAKES	SHIMANO XTR TRAIL, 180/160MM
SIZES	S, M, L, XL



TRIGGER CARBON 2

FRAME	TRIGGER, 120/70MM, BALLISTEC HI-MOD CARBON
SUSPENSION F/R	LEFTY PBR 130 26 / FOX DYAD RT2 120/70MM
WHEELS	MAVIC CROSSTRAIL W/ LEFTY

TIRES	SCHWALBE RACING RALPH PERFORMANCE, 2.25"
CRANKS	SRAM S1400, BB30, 38/24 W/GUARD
DERAILLEUR R/F	SRAM X9 TYPE 2/ X7

MAGNESIUM WHITE W/ JET BLACK AND ULTRA BLUE ACCENTS, GLOSS (BLU)

SHIFTERS	SRAM X9
BRAKES	MAGURA MT2 W/BAT, 180/160MM
SIZES	S, M, L, XL



> JEROME CLEMENTZ.

“3 parole per descrivere la Cannondale
Trigger: Efficiente, Regolabile e Divertente”



LEFTY

> PRESTAZIONI SUPERIORI GRAZIE AL DESIGN NON CONVENZIONALE.

La sospensione anteriore PIÙ LEGGERA/RIGIDA/ROBUSTA/MORBIDA —
Ora con TECNOLOGIA A CUSCINETTI AD AGHI IBRIDI SIGILLATI

> LA LEFTY È PIÙ LEGGERA

Il design minimalista a stelo singolo di Lefty le consente di essere più leggera rispetto alla maggior parte delle forcelle da gara XC più leggere della concorrenza.

> LA LEFTY È PIÙ RESISTENTE

Le doppie corone e la struttura oversize invertita di Lefty le danno una tale resistenza che persino la Lefty più leggera può presentare prestazioni superiori alle robuste forcelle all-mountain nei test distruttivi.

> LA LEFTY È PIÙ RIGIDA

La robusta struttura della Lefty, combinata al design “scatolare” dell’ammortizzatore e il cuscinetto di scorrimento inferiore la rendono più rigida a livello torsionale rispetto a qualsiasi forcella al mondo per un’estrema precisione dello sterzo.

> LA LEFTY È PIÙ LINEARE

Il fulcro della Lefty, ovvero la tecnologia con cuscinetti ad aghi ibridi brevettata di Cannondale, garantisce il libero movimento delle sospensioni, indipendentemente dal carico. Anche quando sottoposta alle forze di frenata, impatto e sterzata più intense, la ruota riesce a seguire il terreno in maniera fluida per il massimo controllo.

> LEFTY È SENZA PROBLEMI

Il nuovo design ibrido consente all’intera struttura della forcella di essere completamente sigillata contro gli elementi per una vita di servizio lunga ed è dotata di cuscinetti ad aghi auto-resettanti per eliminare la necessità di ricorrenti reset manuali.



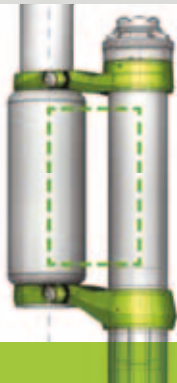

> DDESIGN INVERTITO A DOPPIA CORONA

Con il tubo della forcella più rigido e più grande sulla sommità dove può combattere con maggiore efficacia la flessione e aggiungere resistenza, e doppie corone che lo collegano saldamente al tubo sterzo, il design non convenzionale della Lefty è semplicemente il modo più leggero, rigido e resistente di realizzare una forcella.



> DESIGN "SQUARE IN SQUARE"

Le piste dei cuscinetti ad aghi creano un'interfaccia di tipo "a doppio quadrato concentrico" tra il fodero e lo stelo della forcella, impedendo ai due tubi di ruotare l'uno rispetto all'altro come invece succede con il design delle forcelle tradizionali. E' il motivo per cui Lefty e' cosi' incredibilmente rigida e precisa."



> SISTEMA CON CUSCINETTI AD AGHI IBRIDI

Cuscinetti ad aghi senza frizione offrono una sospensione di una morbidezza impareggiabile in tutte le condizioni di carico, mentre il cuscinetto di scorrimento inferiore fornisce un ulteriore supporto per una maggiore rigidità e precisione di sterzo mano a mano che la forcella avanza nell'escursione.



> SISTEMA DI SIGILLATURA DURATHON

Un vasto sistema di sigillatura interno ed esterno mantiene la roba buona all'interno e la schifezza fuori, consentendo di più che raddoppiare i tempi tra i servizi raccomandati rispetto alla nostra concorrenza.



SUPERMAX 29'ER

> LEFTY DIVENTA GRANDE.

La SuperMax tutta nuova prende tutto ciò che rende grande la Lefty e lo rende ancora più grande. Il risultato: una forcella rigida e forte come la maggior parte delle forcelle DH a doppia piastra, tuttavia più leggera della maggior parte delle forcelle all-mountain. Proprio quel che serve per 29' a escursione più lunga.



> MASSICCIAMENTE OVERSIZE

Lo stelo inferiore della SuperMax misura 36 mm di diametro, mentre l'enorme stelo superiore raggiunge i 46mm per la massima rigidità e precisione di sterzo.

> COMPATIBILE CON ATTACCHI MANUBRIO CORTI

Per accomodare le attuali impostazioni per il riding su trail, l'asse decentrato consente allo stelo della forcella di arretrare ulteriormente, creando uno spazio sufficiente per montare attacchi manubrio corti, anche da 50 mm.

> TAGLIE MULTIPLE

Per garantire che i rider riescano a ottenere la migliore calzata sulle 29'er a escursione lunga, la SuperMax viene proposta con diverse spaziatore tra le piastre per adattarsi a differenti lunghezze del tubo sterzo.

> MOZZO PIÙ LARGO

Il nuovo mozzo SuperMax Lefty è dotato di una maggiore distanza tra le flange che consente una migliore angolazione dei raggi per ruote più robuste e più rigide.

> LEFTY OPZIONI.



> SUPERMAX CARBON

- La forcella Lefty più rigida e robusta
- Fodero esterno in carbonio unidirezionale multistrato oversize
- Piastre in lega d'alluminio
- Stelo oversize in lega d'alluminio con asse ruota offset



> LEFTY CARBON

- Le forcella Lefty più leggera
- Fodero esterno in carbonio unidirezionale multistrato
- Piastre in lega d'alluminio
- Stelo/asse ruota in pezzo unico forgiato OPI



> LEFTY OPI ALLOY

- Leggera e resistente, con linee elegantemente raccordate
- Fodero in lega d'alluminio e piastre forgiate in pezzo unico con processo OPI di Cannondale
- Stelo/asse ruota in pezzo unico forgiato OPI



> XLR

- Bloccaggio remoto idraulico "Xloc"* sul manubrio con regolazione separata del ritorno
- Controllo forcella a portata di pollice

*Grazie ai nostri amici di RockShox



> PBR

- Bloccaggio a pulsante con regolazione del ritorno integrati sulla testa della forcella
- Facile da utilizzare (molto più facile da raggiungere di qualsiasi altro lockout posto sulla sommità della forcella)

> PROGRAMM 2013

	CORSA	RUOTA	PESO
SUPERMAX	130	29"	1850
LEFTY CARBON XLR	130	26"	1315
	120	26"	1320
	100	26"	1250
	100	29"	1332
	90	29"	1342
LEFTY XLR	130	26"	1435
	120	26"	1440
	100	26"	1394
	100	29"	1445
	90	29"	1455
LEFTY PBR	130	26"	1381
	120	26"	1391
	100	26"	1334
	100	29"	1408
	90	29"	1418

SCALPEL 29ER

> DISTINGUITI.

Questa 29'er a doppia sospensione, ultraleggera e super maneggevole attacca senza il minimo sforzo serpentine, sentieri tortuosi e sfreccia sui rettilinei. Con la sua forcella Lefty ultra precisa e una geometria da 29'er corsaiola e reattiva, la Scalpel 29'er fonde l'inarrestabile inerzia delle 29'er con la velocità e l'agilità di una 26'er - esattamente quello che cercano i rider estremi su trail veloci, gli atleti marathon e i racer XC.



> STRUTTURA SUPERLEGGERA

I telai ultra-leggeri sono disponibili in versione in carbonio BallisTec oppure in lega SmartFormed. Aggiungi System Integration della forcella Lefty, attacco manubrio/canotto sterzo OPI e otterrai un peso complessivo che i nostri concorrenti possono solo sognarsi.



> CARATTERISTICHE DI POTENZIAMENTO DELLA RIGIDITÀ

Una coppia di link ammortizzatore robusti, in alluminio lavorato a macchina con assi passanti ECS-TC da 15 mm bloccati nel link dell'ammortizzatore e nello snodo principale per eliminare flessione e gioco, fornendo un'accelerazione scattante e un controllo preciso.



> FODERI ALTI ZERO-PIVOT

Mediante una stratificazione precisa del carbonio, i foderi bassi sono studiati per flettersi verticalmente pur rimanendo estremamente rigidi lateralmente e a livello torsionale per la migliore miscela di leggerezza e rigidità reattiva. Le Scalpel in lega vengono dotate di doppi cuscinetti ECS-TC, come la Jekyll, nei perni dei forcellini al posto dei foderi di Zero Pivot, per la massima rigidità.

LEFTY
 HYBRID



SCALPEL 29ER CARBON ULTIMATE

FRAME	SCALPEL 29'ER, 100MM, BALLISTEC HI-MOD CARBON
SUSPENSION F/R	LEFTY CARBON XLR 100 29/ FOX FACTORY CTD KASHIMA 100MM
WHEELS	ENVE TWENTY9 XC CARBON W/LEFTY & DT SWISS 240

TIRES	SCHWALBE RACING RALPH, 2.1" EVO TUBELESS READY
CRANKS	CANNONDALE HOLLOGRAM SI SL, 39/26
DERAILLEUR R/F	SHIMANO XTR SHADOW + / SRAM XX

EXPOSED CARBON, MATTE (CRB)

SHIFTERS	SHIMANO XTR
BRAKES	MAGRUA MT8 160/160MM
SIZES	S, M, L, X



SCALPEL 29ER CARBON 1

FRAME	SCALPEL 29'ER, 100MM, BALLISTEC HI-MOD CARBON
SUSPENSION F/R	LEFTY CARBON XLR 100 29 / SRAM XX W/ X-LOC 100MM
WHEELS	REYNOLDS XC CARBON 29'ER W/ LEFTY

TIRES	SCHWALBE RACING RALPH, 2.1" EVO TUBELESS READY
CRANKS	SRAM XO, BB30, 38/24
DERAILLEUR R/F	SRAM XO / SRAM XO

EXPOSED CARBON W/MAGNESIUM WHITE AND ULTRA BLUE (GLOSS) (BLK)

SHIFTERS	SRAM XO
BRAKES	AVID XO CARBON 180 / 180MM
SIZES	S, M, L, X



SCALPEL 29ER CARBON 2

FRAME	SCALPEL 29'ER, 100MM, BALLISTEC HI-MOD CARBON
SUSPENSION F/R	LEFTY XLR 100 29 / ROCKSHOX MONARCH RT3 100MM
WHEELS	STAN'S ZTR ARCH EX 29'ER W/ LEFTY & SUN RINGLE HUBS

TIRES	SCHWALBE RACING RALPH, 2.1" EVO TUBELESS READY
CRANKS	SRAM S2210, BB30, 38/24
DERAILLEUR R/F	SHIMANO XTR SHADOW + / SRAM X9

EXPOSED CARBON W/ MAGNESIUM WHITE AND BERSERKER GREEN ACCENTS, GLOSS (GRN)

SHIFTERS	SHIMANO XT
BRAKES	AVID ELIXIR 9 CARBON, 180/160MM
SIZES	S, M, L, X



> MANUEL FUMIC.

“Le gare XC sono, in sostanza, una miscela di sofferenza e divertimento. La Scalpel 29er rende la parte di sofferenza più facile ed è davvero costruita per la parte divertente”



SCALPEL 29ER 3

FRAME SCALPEL 29"ER, 100MM, SMARTFORMED ALLOY

SUSPENSION F/R LEFTY PBR 100 29 / FOX PERFORMANCE CTD 100MM

WHEELS WTB ST 119 W/ LEFTY & FORMULA HUBS

TIRES SCHWALBE RACING RALPH PERFORMANCE 2.25"

CRANKS SRAM S1000, BB30, 38/24

DERAILLEUR R/F SRAM X9 / X7

MAGNESIUM WHITE, GLOSS (WHT)

SHIFTERS SRAM X7

BRAKES AVID ELIXIR 5 180/160MM

SIZES S, M, L, X



SCALPEL 29ER 4

FRAME SCALPEL 29"ER, 100MM, SMARTFORMED ALLOY

SUSPENSION F/R ROCKSHOX RECON GOLD TK 29, 80MM / XFUSION E1 RL 100MM

WHEELS SUN RINGLE INFERNO25 W/ FORMULA HUBS

TIRES SCHWALBE RAPID ROB 2.25"

CRANKS FSA COMET, BB30, 42/32/24

DERAILLEUR R/F SHIMANO XT / SLX

JET BLACK, GLOSS (BLK)

SHIFTERS SHIMANO DEORE

BRAKES AVID ELIXIR 3, 180/160MM

SIZES S, M, L, X

RZ ONE TWENTY

➤ A PROVA DI QUALSIASI PERCORSO, PRONTA ALLA GARA.

Questo raffinato design single-pivot è il culmine di anni di esperienza nella doppia sospensione. Il telaio leggero e rigido e la sospensione morbida offrono una qualità di guida bilanciata, efficiente e divertente, rendendo la RZ la scelta perfetta per i racer del fine settimana e per rider su trail "all day". I modelli pronti per la competizione RZ One Twenty XLR sono dotati di specifica componentistica migliorata e una forcella Lefty con escursione di 120 mm.



LEFTY
HYBRID

RZ120 XLR 1

FRAME RZ ONE TWENTY, 120MM, SMARTFORMED ALLOY

SUSPENSION F/R LEFTY XLR 120 26 / ROCKSHOX MONARCH RT3

WHEELS SUN RINGLE BLACK FLAG PRO W/ LEFTY

TIRES SCHWALBE RACING RALPH PERFORMANCE, 2.25"

CRANKS SRAM S2210, BB30, 38/24

DERAILLEUR R/F SRAM XX / XO

JET BLACK W/MAGNESIUM WHITE, RACE RED ACCENTS, GLOSS (BLK)

SHIFTERS SRAM XO

BRAKES AVID ELIXIR 9 CARBON, 180/160MM

SIZES S,M,L,X

➤ ESCURSIONE A PIÙ STADI

Un ammortizzatore regolato in modo personalizzato, abbinato a uno swing link di precisione, fornisce 120 mm di corsa perfetta a più stadi, morbida all'inizio, lineare nella fase centrale per una pedalata efficiente e più stabile alla fine per evitare i finecorsa.

➤ MANOVRABILITÀ ECCELLENTE

Miscela perfetta di stabilità e agonismo, la geometria della RZ ti consente di sentirti perfettamente a tuo agio e mantenere il controllo indipendentemente da cosa tiene in serbo per te la montagna, rendendo questa bike da trail una perfetta macchina a tutto tondo.

➤ ALLUMINIO SMARTFORMED

Un complesso mix di idroformatura, sagomatura meccanica, spessore variabile, saldatura liscia a doppio passaggio e il tubo reggisella Backbone 3D OPI (One Piece Integration) forgiato, scatola del movimento centrale e link ammortizzatore offrono il massimo della resistenza e il minimo del peso.



RZ120 XLR 2

FRAME	RZ ONE TWENTY, 120MM, SMARTFORMED ALLOY
SUSPENSION F/R	LEFTY XLR 120 26 / FOX FLOAT CTD PERFORMANCE
WHEELS	STANS ZTR CREST 26 W/ LEFTY & SUN RINGLE HUBS

TIRES	SCHWALBE RACING RALPH PERFORMANCE, 2.25"
CRANKS	SRAM S2210, BB30, 44/33/22
DERAILLEUR R/F	SHIMANO XTR SHADOW+ / SRAM X9

JET BLACK W/ MAG WHITE, ULTRA BLUE, RACE RED ACCENTS, GLOSS (BLU)

SHIFTERS	SHIMANO XT
BRAKES	MAGURA MT4, 180/160MM
SIZES	S,M,L,X



RZ120 XLR 3

FRAME	RZ ONE TWENTY, 120MM, SMARTFORMED ALLOY
SUSPENSION F/R	LEFTY PBR 120 26/ FOX FLOAT CTD EVOLUTION
WHEELS	WTB FREQUENCY RACE 119 W/LEFTY & FORMULA HUBS

TIRES	SCHWALBE RACING RALPH PERFORMANCE, 2.25"
CRANKS	SRAM S1000, BB30, 44/33/22
DERAILLEUR R/F	SRAM X9 / X7

JET BLACK W/ CHARCOAL GRAY AND MAG WHITE ACCENTS, MATTE (BBQ)

SHIFTERS	SRAM X9
BRAKES	AVID ELIXIR 5, 180/160MM
SIZES	S,M,L,X



RZ120 1

FRAME	RZ ONE TWENTY, 120MM, SMARTFORMED ALLOY
SUSPENSION F/R	ROCKSHOX RECON GOLD TK, 120MM / ROCKSHOX MONARCH RL 120MM
WHEELS	MADDUX DC3.0 W/FORMULA HUBS

JET BLACK, GLOSS (BLK)	
TIRES	SCHWALBE RAPID ROB 2.25"
CRANKS	SRAM S800 3.2, 44/32/22
DERAILLEUR R/F	SRAM X7 /X5

JET BLACK, MATTE (BBQ)	
SHIFTERS	SRAM X5
BRAKES	AVID ELIXIR 3, 180/160MM
SIZES	S,M,L,X



RZ120 2

FRAME	RZ ONE TWENTY, 120MM SMARTFORMED ALLOY
SUSPENSION F/R	X-FUSION VELVET RL, 120MM / X-FUSION E1 RL 120MM
WHEELS	MADDUX DC3.0 W/FORMULA HUBS

MAGNESIUM WHITE, GLOSS (WHT)	
TIRES	SCHWALBE RAPID ROB 2.25"
CRANKS	SHIMANO M552 42/32/24
DERAILLEUR R/F	SHIMANO SLX / DEORE

JET BLACK, MATTE (BBQ)	
SHIFTERS	SHIMANO DEORE
BRAKES	AVID ELIXIR 1, 180/160MM
SIZES	S,M,L,X

SCALPEL RACE

> LA PIÙ POTENTE ARMA DA COMPETIZIONE CROSS-COUNTRY.

Concepita per i rider XC hardcore che vogliono una performance da doppia sospensione a un peso inferiore di quello della maggior parte delle hardtail. La combinazione di struttura in carbonio BallisTec, foderi Zero Pivot e componenti System Integration come la forcella Lefty e l'attacco/tubo sterzo OPI rendono la Scalpel la bici da gara a doppia sospensione più leggera, rigida e reattiva mai creata.



SCALPEL RACE 2

FRAME	SCALPEL, 80MM, BALLISTEC HI-MOD FULL CARBON, ZERO PIVOT
SUSPENSION F/R	LEFTY XLR 100 26 / ROCKSHOX MONARCH RL 80MM
WHEELS	MAVIC CROSSTRAIL W/ LEFTY

TIRES	SCHWALBE RACING RALPH EVO, 2.1" TUBELESS READY
CRANKS	SRAM S2210, BB30, 42/28
DERAILLEUR R/F	SRAM X0 / SRAM X9

EXPOSED CARBON W/ MAGNESIUM WHITE AND BERSERKER GREEN ACCENTS, GLOSS (GRN)

SHIFTERS	SRAM X9
BRAKES	AVID ELIXIR 9 CARBON 160/140MM
SIZES	S,M,L,X

> CARBONIO BALLISTEC

Grazie all'uso di fibre sviluppate nel settore militare per le armi balistiche, questa struttura in carbonio estremamente resistente consente di realizzare un telaio ultraleggero ma, in proporzione, più forte dell'acciaio.

> SISTEMA FODERI POSTERIORI ZERO PIVOT

Grazie alla sofisticata stratificazione del carbonio, i foderi bassi e quelli alti sono progettati per flettersi verticalmente, rimanendo invece molto rigidi lateralmente, per fornire 80 mm di corsa effettiva della ruota posteriore, eliminando al contempo il peso dei perni dei cuscinetti.

> SYSTEM INTEGRATION

Progettare la Scalpel Race attorno a componenti System Integration come le nostre forcelle Lefty e gli attacchi/tubi sterzo Si OPI consente ai nostri telai, già i più leggeri della categoria, a diventare bici complete incomparabilmente leggere.



LEFTY
 HYBRID

SCALPEL RACE 3

FRAME	SCALPEL, 80MM, BALLISTEC HI-MOD FULL CARBON, ZERO PIVOT
SUSPENSION F/R	LEFTY PBR 100 26 / FOX PERFORMANCE CTD
WHEELS	WTB PHASE 119

TIRES	SCHWALBE RACING RALPH 2.1" TUBELESS READY
CRANKS	SRAM S1400, BB30, 42/28
DERAILLEUR R/F	SHIMANO XT / SRAM X7

EXPOSED CARBON W/ MAGNESIUM WHITE AND BERSERKER GREEN ACCENTS, GLOSS (GRN)

SHIFTERS	SHIMANO SLX
BRAKES	AVID ELIXIR 7 160/140MM
SIZES	S,M,L,X



F29

> LA 29'ER PIÙ RAFFINATA.

Racer e puristi della hardtail ovunque hanno scoperto che la Cannondale F29s offre il massimo delle prestazioni 29'er. Con i loro telai ultraleggeri, ultra-rigidi, la tecnologia a micro-sospensione SPEED SAVE e la geometria da gara 29'er, le F29 combinano il peso leggero e l'agilità di bike con ruote 26" alla inarrestabile inerzia delle "big wheel".

DISPONIBILE IN 3 OPZIONI TELAIO:

Estremamente leggera Hi-MOD BallisTec Carbon, ultra-leggera BallisTec Carbon, o super-leggera SmartFormed Alloy



> REGGISELLA SAVE

Mediante l'uso di stratificazioni sofisticate del carbonio il nostro reggisella SAVE aggiunge al telaio oltre 20 mm di potenziamento del comfort, assorbimento e smorzamento degli urti. Questo si traduce in una minore fatica e un maggiore comfort, permettendoti di rimanere in sella più a lungo e di andare più veloce.



> LEFTY SYSTEM INTEGRATION

L'estrema leggerezza e precisione delle nostre forcelle Lefty è un vantaggio ancora maggiore sulle 29'er. La sua eccellente rigidità e la sua leggerezza fanno una differenza ancora maggiore sulle bici con le ruote più grandi. Se combinata con il superleggero attacco manubrio/canotto sterzo OPI e l'Hollowgram SL BB30, la System Integration di Cannondale consente di risparmiare centinaia di grammi.



> TECNOLOGIA DI ELIMINAZIONE DELLE VIBRAZIONI SPEED SAVE

I foderi posteriori SPEED SAVE creano un micro sistema di sospensione messo a punto per il riding consentendo alla ruota posteriore di seguire il terreno, migliorando il controllo, la trazione e la manovrabilità. Questo consente alla bici di correre più veloce, accelerare meglio e curvare più intensamente.



LEFTY
HYBRID

F29 CARBON ULTIMATE

FRAME	F29, BALLISTEC HI-MOD CARBON, SPEED SAVE
SUSPENSION F/R	LEFTY CARBON XLR 90 29
WHEELS	ENVE TWENTY9 XC CARBON W/LEFTY & DT SWISS 240

TIRES	SCHWALBE RACING RALPH, 2.1" EVO TUBELESS READY
CRANKS	CANNONDALE HOLLOGRAM SI SL, 39/26
DERAILLEUR R/F	SRAM XX / SRAM XX

EXPOSED CARBON W/ NEARLY BLACK AND CHARCOAL GRAY ACCENTS, MATTE (CRB)

SHIFTERS	SRAM XX
BRAKES	MAGURA MT8, 160/140MM
SIZES	M, L, XL



F29 CARBON 1

FRAME	F29, BALLISTEC HI-MOD CARBON, SPEED SAVE
SUSPENSION F/R	LEFTY CARBON XLR 90 29
WHEELS	REYNOLDS XC CARBON 29"ER W/ LEFTY

EXPOSED CARBON W/ BERSERKER GREEN (REP)	
TIRES	SCHWALBE RACING RALPH, 2.1" EVO TUBELESS READY
CRANKS	SRAM S2210, BB30, 38/24
DERAILLEUR R/F	SHIMANO XTR SHADOW +/- SRAM XO

MAGNESIUM WHITE W/ RACE RED AND ULTRA BLUE ACCENTS, GLOSS (RED)	
SHIFTERS	SHIMANO XTR
BRAKES	SRAM XO CARBON, 180/160MM
SIZES	M, L, XL



F29 CARBON 2

FRAME	F29, BALLISTEC CARBON, SPEED SAVE
SUSPENSION F/R	LEFTY XLR 90 29
WHEELS	STAN'S ZTR ARCH EX 29"ER W/ LEFTY & SUN RINGLE HUBS

MAGNESIUM WHITE W/ CHARCOAL GRAY AND RUBY RED ACCENTS (GLOSS) (GRY)	
TIRES	SCHWALBE RACING RALPH, 2.1" EVO TUBELESS READY
CRANKS	SRAM S2210, BB30, 38/24
DERAILLEUR R/F	SRAM XO / X7

MAGNESIUM WHITE W/ CHARCOAL GRAY AND RUBY RED ACCENTS (GLOSS) (GRY)	
SHIFTERS	SRAM X9
BRAKES	AVID ELIXIR 9 CARBON, 180/160MM
SIZES	M, L, XL



LEFTY
HYBRID

F29 CARBON 3

FRAME	F29, BALLISTEC CARBON, SPEED SAVE
SUSPENSION F/R	LEFTY PBR 90 29
WHEELS	WTB FREQUENCY RACE 119 W/ LEFTY, SHIMANO M525

TIRES	SCHWALBE RACING RALPH PERFORMANCE 2.25" TUBLESS READY
CRANKS	SRAM S1000, BB30, 38/24
DERAILLEUR R/F	SHIMANO XT SHADOW + / SRAM X7

EXPOSED CARBON W/ MAGNESIUM WHITE AND BERSERKER GREEN ACCENTS, GLOSS(WHT)

SHIFTERS	SHIMANO SLX
BRAKES	AVID ELIXIR 7, 180/160MM
SIZES	M, L, XL

> MARCO FONTANA.

“La F29-er è l’arma perfetta per i più duri percorsi XCO del mondo. Leggera, veloce, confortevole. Bene, credo di aver dimenticato bella e sexy.”





LEFTY
HYBRID

F29 1

FRAME	F29, SMARTFORMED ALLOY, SPEED SAVE
SUSPENSION F/R	LEFTY PBR 90 29
WHEELS	WTB FREQUENCY RACE 119 W/ LEFTY, SRAM X9

TIRES	SCHWALBE RAPID ROB 2.25"
CRANKS	SRAM S1400 BB30, 38/24
DERAILLEUR R/F	SRAM X9 / X7

MAGNESIUM WHITE, GLOSS (WHT)	
SHIFTERS	SRAM X9
BRAKES	AVID ELIXIR 7, 180/160MM
SIZES	S, M, L, XL



LEFTY
HYBRID

F29 2

FRAME	F29, SMARTFORMED ALLOY, SPEED SAVE
SUSPENSION F/R	LEFTY PBR 90 29
WHEELS	FREQUENCY RACE 119 W/ LEFTY, SHIMANO M525

JET BLACK, MATTE (BBQ)	
TIRES	WTB NINE LINE 2.0"
CRANKS	SHIMANO M552, 42/32/24
DERAILLEUR R/F	SHIMANO XT SHADOW + / DEORE

MAGNESIUM WHITE, GLOSS (WHT)	
SHIFTERS	SHIMANO SLX
BRAKES	MAGURA MT.2, 180/160MM
SIZES	S, M, L, XL



LEFTY
 HYBRID

F26 CARBON 2

FRAME	F26, BALLISTEC HI-MOD CARBON, SPEED SAVE
SUSPENSION F/R	LEFTY XLR 100 26
WHEELS	MAVIC CROSSTAIL W/ LEFTY

TIRES	SCHWALBE RACING RALPH EVO, 2.1"
CRANKS	SRAM S2210, BB30, 42/28
DERAILLEUR R/F	SRAM X0 / SRAM X9

EXPOSED CARBON W/MAGNESIUM WHITE AND BERSERKER GREEN ACCENTS, GLOSS (GRN)

SHIFTERS	SRAM X9
BRAKES	AVID ELIXIR 9 CARBON 160/140MM
SIZES	S, M, L



F26 CARBON 3

FRAME	F26, BALLISTEC HI-MOD CARBON, SPEED SAVE
SUSPENSION F/R	CANNONDALE FATTY DLR80, 80MM
WHEELS	SHIMANO MT-66

TIRES	SCHWALBE RACING RALPH 2.1" TUBELESS READY
CRANKS	SRAM S1400, BB30, 42/28
DERAILLEUR R/F	SHIMANO XT / SRAM X7

SHIFTERS	SHIMANO SLX
BRAKES	AVID ELIXIR 7 160/140MM
SIZES	S, M, L



LEFTY
HYBRID

F26 1

FRAME	F26, SMARTFORMED ALLOY, SPEED SAVE
SUSPENSION F/R	LEFTY PBR 100 26
WHEELS	MAVIC XM319 W/ LEFTY & SRAM X9

TIRES	SCHWALBE RACING RALPH PACE STAR, 2.1", TUBELESS READY
CRANKS	SRAM S1400, BB30, 39/26
DERAILLEUR R/F	SRAM X9 / X7

MAGNESIUM WHITE, GLOSS (WHT)

SHIFTERS	SRAM X9
BRAKES	MAGURA MT2 W/BAT, 160/160MM
SIZES	S, M, L, XL



F26 3

FRAME	F26, SMARTFORMED ALLOY, SPEED SAVE
SUSPENSION F/R	CANNONDALE FATTY DLR80, 80MM
WHEELS	MADDUX DC3.0 W/ FORMULA HUBS

TIRES	SCHWALBE RAPID ROB 2.1"
CRANKS	SHIMANO M552, 42/32/24
DERAILLEUR R/F	SHIMANO XT SHADOW + / DEORE

JET BLACK, MATTE (BBQ)

SHIFTERS	SHIMANO SLX
BRAKES	SHIMANO M596 DEORE, 160/160MM
SIZES	S, M, L, X

TRAIL SL

> LE SUPERBIKE ACCESSIBILI.

Con caratteristiche di peso e tecnologia che competono con qualsiasi cosa fosse presente sul circuito della World Cup solo pochi anni fa, la serie Trail SL dimostra che non è necessario spendere un mucchio di soldi per avere una performance davvero eccezionale. Disponibile sia nella versione 26" che 29", c'è una Trail SL per tutti, dal rider della prima ora all'esperto veterano del trail.



TRAIL SL 29ER 1

FRAME	TRAIL SL 29'ER, OPTIMIZED 6061 ALLOY, SAVE
SUSPENSION F/R	ROCKSHOX RECON GOLD TK 29 80MM, W/ LOCKOUT
WHEELS	MADDUX DC3.0 29'ER W/ SHIMANO HUBS

MAGNESIUM WHITE, GLOSS (WHT)

TIRES	WTB NINE LINE 2.0"
CRANKS	FSA COMET, 42/32/24
DERAILLEUR R/F	SHIMANO XT / DEORE

JET BLACK, MATTE (BBQ)

SHIFTERS	SHIMANO DEORE
BRAKES	SHIMANO BR-M505, 180/160MM
SIZES	S, M, L, X, J

> TELAIO NUOVISSIMO

Modellata sulle nostre bike della serie F di alta gamma, i telai Trail SL sono stati completamente ridisegnati per il 2013 con tubazioni nuove più leggere, forcellini più leggeri e caratteristiche SAVE più esagerate. Più leggera, più rigida, più morbida ... migliore.

> MAESTRIA CANNONDALE CON L'ALLUMINIO

Forme delle tubazioni complesse, inspessimento interno morbido e le nostre caratteristiche saldature lisce a doppio passaggio illustrano la maestria nei telai in alluminio Cannondale. Il nostro meticoloso processo elimina molti elementi di stress e punti deboli tradizionalmente tipici dei telai saldati, consentendoci di costruire telai più leggeri e più resistenti.

> GEOMETRIA RACE 29'ER

Nuova per il 2013, la Trail SL 29'er ottiene la nostra geometria da gara 29'er dalla manovrabilità agile. Il passo più breve e l'angolo di testa più stretto le conferiscono una sensazione incredibilmente rapida, agile e precisa.



TRAIL SL 29ER 2

FRAME	TRAIL SL 29"ER, OPTIMIZED 6061 ALLOY, SAVE
SUSPENSION F/R	ROCKSHOX RECON SILVER TK 29 80MM, W/ LOCKOUT
WHEELS	MADDUX DC3.0 29"ER W/ FORMULA HUBS

JET BLACK W/GREEN ACCENTS, GLOSS (BLK)	
TIRES	WTB NINE LINE 2.0"
CRANKS	SHIMANO M522, 42/32/24
DERAILLEUR R/F	SHIMANO SLX / DEORE

JET BLACK, GLOSS (BLK)	
SHIFTERS	SHIMANO DEORE
BRAKES	AVID ELIXIR 1, 180/160MM
SIZES	S, M, L, X, J



TRAIL SL 29ER 4

FRAME	TRAIL SL 29"ER, OPTIMIZED 6061 ALLOY, SAVE
SUSPENSION F/R	SR SUNTOUR XCR-LO-29, COIL, 80MM, W/ LOCKOUT
WHEELS	MADDUX DC3.0 29"ER W/ C4 HUBS

JET BLACK W/GREEN ACCENTS, GLOSS (BLK)	
TIRES	WTB NINE LINE 2.0"
CRANKS	SHIMANO FC-M391-8, 44/32/22
DERAILLEUR R/F	SHIMANO ALIVIO / ALIVIO

MAGNESIUM WHITE, GLOSS (WHT)	
SHIFTERS	SHIMANO ACERA
BRAKES	CANNONDALE HELIX 6 HYDRAULIC DISC, 180/160MM
SIZES	S, M, L, X, J



TRAIL SL 1

FRAME	TRAIL SL, OPTIMIZED 6061 ALLOY, SAVE
SUSPENSION F/R	ROCKSHOX RECON GOLD TK 100MM, W/ LOCKOUT
WHEELS	MADDUX DC3.0 W/ SHIMANO HUBS

TIRES	SCHWALBE RAPID ROB 2.1"
CRANKS	FSA COMET, 42/32/24
DERAILLEUR R/F	SHIMANO XT / DEORE

JET BLACK, GLOSS (BLK)

SHIFTERS	SHIMANO DEORE
BRAKES	SHIMANO BR-M505, 160/160MM
SIZES	S, M, L, X



> WORLD OF MTB JUNE 2012.

“Cannondale Can! Sentieri veloci, radici, polverose tagliafuoco e piste innevate. Nulla è impossibile.”



TRAIL SL 2

FRAME	TRAIL SL, OPTIMIZED 6061 ALLOY, SAVE
SUSPENSION F/R	ROCKSHOX RECON SILVER TK 100MM, W/ LOCKOUT
WHEELS	MADDUX DC3.0 W/ FORMULA HUBS

TIRES	SCHWALBE RAPID ROB 2.1"
CRANKS	SHIMANO M522, 42/32/24
DERAILLEUR R/F	SHIMANO SLX / DEORE

MAGNESIUM WHITE (GLOSS) (WHT)	
SHIFTERS	SHIMANO DEORE
BRAKES	AVID ELIXIR 1, 160/160MM
SIZES	S, M, L, X



TRAIL SL 3

FRAME	TRAIL SL, OPTIMIZED 6061 ALLOY, SAVE
SUSPENSION F/R	ROCKSHOX XC 30 TK, COIL, 100MM W/ LOCKOUT
WHEELS	MADDUX DC3.0 W/ C4 HUBS

TIRES	SCHWALBE RAPID ROB 2.1"
CRANKS	SHIMANO FC-M430-8, 44/32/22
DERAILLEUR R/F	SHIMANO DEORE / ACERA

JET BLACK, MATTE (BBQ)	
SHIFTERS	SHIMANO ALIVIO
BRAKES	SHIMANO BR-M446, 160/160MM
SIZES	S, M, L, X



TRAIL SL 4

FRAME	TRAIL SL, OPTIMIZED 6061 ALLOY, SAVE
SUSPENSION F/R	SR SUNTOUR XCR-LO, COIL, 100MM W/ LOCKOUT
WHEELS	MADDUX DC3.0 W/ C4 HUBS

RACE RED, GLOSS (RED)	
TIRES	SCHWALBE RAPID ROB 2.1"
CRANKS	SHIMANO FC-M391-8, 44/32/22
DERAILLEUR R/F	SHIMANO ALIVIO / ACERA

JET BLACK, GLOSS (BLK)	
SHIFTERS	SHIMANO ACERA
BRAKES	CANNONDALE HELIX 6 HYDRAULIC DISC, 160/160MM
SIZES	S, M, L, X



TRAIL SL 5

FRAME	TRAIL SL, OPTIMIZED 6061 ALLOY, SAVE
SUSPENSION F/R	SR SUNTOUR XCM-HLO, COIL, 100MM W/ LOCKOUT
WHEELS	MADDUX DC3.0 W/ C4 HUBS

JET BLACK, GLOSS (BLK)	
TIRES	SCHWALBE RAPID ROB 2.1"
CRANKS	SHIMANO, FC-M311, 42/32/22
DERAILLEUR R/F	SHIMANO ACERA / ALTUS

JET BLACK, GLOSS (BLK)	
SHIFTERS	SHIMANO ALTUS
BRAKES	CANNONDALE HELIX 6 HYDRAULIC DISC, 160/160MM
SIZES	S, M, L, X



ROAD

BICICLETTE DA STRADA CANNONDALE: PERFORMANCE ALLO STATO PURO.

Dai record delle SuperSix EVO e CAAD10 al comfort dell'uso quotidiano della Synapse, le bici da strada Cannondale sono concepite per fornire performance allo stato puro. Le più leggere nella loro categoria, l'equilibrio perfetto tra rigidità e vivace comportamento di guida in puro stile Cannondale.



> ELITE ROAD

SUPERSIX EVO
SUPERSIX
CAAD10
CAAD8

Biciclette ultra-leggere, efficienti, concepite per la competizione e costruite per farvi tagliare il traguardo per primi.

> PERFORMANCE ROAD

SYNAPSE CARBON
SYNAPSE ALLOY

Prestazioni da gara incontrano il comfort dell'uso quotidiano. Perfette per Gran Fondo, Cyclo-Sportive e lunghe giornate in sella.

> TRIATHLON/TT

SLICE RS
SLICE

Bici aero high-tech studiate per darvi tutto il vantaggio possibile su vento e cronometro.





> CYCLOCROSS

SUPERX
CAADX

Create per dominare nelle battaglie nel fango del cross racing o per accelerare il vostro percorso mattutino.



SUPERSIX EVO

> “LA BICI MIGLIORE AL MONDO”

La SuperSix EVO è il massimo che si possa desiderare da una bici da corsa su strada. Progettata per essere la miscela perfetta di tutti i fattori chiave della performance – peso, rigidità, resistenza, assorbimento degli urti, manovrabilità e aerodinamica – la EVO è talmente evoluta da aver ricevuto dal Tour magazine in Germania il riconoscimento di “Migliore bicicletta al mondo” (marzo 2012).

OPZIONI TELAIO EVO

- > EVO NANO: Il telaio più leggero prodotto sul pianeta utilizza una struttura avanzata in carbonio BallisTec ad alto modulo e resine da nanotecnologia per un massimo risparmio in termini di peso.
- > EVO HI-MOD: L'EVO originale. La struttura in carbonio BallisTec ad alto modulo garantisce leggerezza e rigidità estreme.
- > EVO CARBON: EVO Carbon: Una struttura con una percentuale superiore di fibra a modulo intermedio BallisTec espande la linea EVO con un telaio dalla performance super elevata inferiore a 950 grammi.



> BALLISTEC CARBON

La tecnica costruttiva in carbonio High Strength di Cannondale consente di realizzare prodotti estremamente leggeri con una rigidità e una resistenza eccezionali.



> SISTEMA DI MICRO-SOSPENSIONE SPEED SAVE

Sottili zone flettenti integrate nei foderi bassi e alti consentono alla ruota di seguire il tracciato del terreno, migliorando la velocità, la manovrabilità e il comfort. Messa a punto per l'uso con la forcella con forcellini offset SPEED SAVE.



> AREA FRONTALE RIDOTTA

Rispetto alle oversize della concorrenza la EVO presenta il tubo obliquo più piccolo del 20% circa, il tubo dello sterzo più piccolo dell'11%, e i foderi della forcella più sottili del 15%. Questo significa area frontale ridotta e meno resistenza aerodinamica. Infatti, i test dimostrano che la EVO ha pochissima resistenza aerodinamica in più rispetto ai migliori telai “aero”, senza il loro peso aggiunto e la loro guida ruvida.



SUPERSIX EVO BLACK EDITION

FRAME	SUPERSIX EVO, BALLISTEC NANO CARBON, SPEED SAVE
FORK	SUPERSIX EVO, SPEED SAVE, BALLISTEC NANO CARBON
WHEELS	ENVE ROAD 25MM 20H FRONT, 24H REAR

TIRES	SCHWALBE ULTREMO LIGHT TUBULAR 22MM
CRANKS	CANNONDALE HOLLOWGRAM SISL2, W/ OPI SPIDERING, 11 SPEED, 53-39 (COMPACT 50/34 INCLUDED)
DERAILLEURS	SHIMANO DURA ACE 9000

JET BLACK W/ 40 BLUE, MATTE (BLE)

SHIFTERS	SHIMANO DURA ACE 9000
BRAKES	SHIMANO DURA ACE 9000
SIZES	48, 50, 52, 54, 56, 58, 60, 63 CM



> PETER SAGAN

“Una bici super leggera rigida negli sprint... e si guida così bene?! Stupefacente! E le impennate all’arrivo sono il tocco di classe.”



SUPERSIX EVO HI-MOD DURA ACE DI2

FRAME	SUPERSIX EVO, BALLISTEC HI-MOD CARBON, DI2 SPECIFIC, SPEED SAVE
FORK	SUPERSIX EVO, SPEED SAVE, BALLISTEC HI-MOD CARBON
WHEELS	MAVIC KSYRIUM SLR WTS

TIRES	MAVIC YKSION, GRIPLINK FRONT AND POWERLINK REAR, 700X23C, FOLDING
CRANKS	CANNONDALE HOLLOWGRAM SISL2, W/ OPI SPIDERING, 11 SPEED, 53-39 (COMPACT 50/34 INCLUDED)
DERAILLEURS	SHIMANO DURA ACE DI2 9070

EXPOSED CARBON W/ CHARCOAL GRAY AND RACE RED ACCENTS, MATTE (CRB)

SHIFTERS	SHIMANO DURA ACE DI2 9070
BRAKES	SHIMANO DURA ACE 9000
SIZES	48, 50, 52, 54, 56, 58, 60, 63 CM



SUPERSIX EVO HI-MOD TEAM

FRAME	SUPERSIX EVO, BALLISTEC HI-MOD CARBON, SPEED SAVE
FORK	SUPERSIX EVO, SPEED SAVE, BALLISTEC HI-MOD CARBON
WHEELS	MAVIC COSMIC CARBONE SLR WTS

TIRES	MAVIC YKSION, GRIPLINK FRONT AND POWERLINK REAR, 700X23C, FOLDING
CRANKS	CANNONDALE HOLLOWGRAM SISL2, W/ OPI SPIDERING, 10 SPEED, 53-39 (COMPACT 50/34 INCLUDED)
DERAILLEURS	SRAM RED

LIQUIGAS TEAM REPLICA, GLOSS (LIQ)

SHIFTERS	SRAM RED DOUBLETAP
BRAKES	SRAM RED
SIZES	48, 50, 52, 54, 56, 58, 60, 63 CM



SUPERSIX EVO DURA ACE

FRAME	SUPERSIX EVO, BALLISTEC HI-MOD CARBON, SPEED SAVE
FORK	SUPERSIX EVO, SPEED SAVE, BALLISTEC HI-MOD CARBON
WHEELS	MAVIC KSYRIUM SLS WTS

TIRES	MAVIC UKSION, GRIPLINK FRONT AND POWERLINK REAR, 700X23C, FOLDING
CRANKS	CANNONDALE HOLLOWGRAM SISL2, W/ OPI SPIDERING, 11 SPEED, 53-39 (COMPACT 50/34 INCLUDED)
DERAILLEURS	SHIMANO DURA ACE 9000

EXPOSED CARBON W/ MAGNESIUM WHITE AND I LOVE GOLD ACCENTS, GLOSS (WHT)

SHIFTERS	SHIMANO DURA ACE 9000
BRAKES	SHIMANO DURA ACE 9000
SIZES	48, 50, 52, 54, 56, 58, 60, 63 CM



SUPERSIX EVO RED RACING EDITION

FRAME	SUPERSIX EVO, BALLISTEC HI-MOD CARBON, SPEED SAVE
FORK	SUPERSIX EVO, SPEED SAVE, BALLISTEC HI-MOD CARBON
WHEELS	VISION TC24, CARBON RIM, 20/24H, TUBULAR

TIRES	SCHWALBE ULTREMO HT TUBULAR 22MM
CRANKS	CANNONDALE HOLLOWGRAM SISL2, FSA CHAINRINGS, 53/39
DERAILLEURS	SRAM RED

EXPOSED CARBON, GLOSS (BLK)

SHIFTERS	SRAM RED DOUBLETAP
BRAKES	SRAM RED
SIZES	48, 50, 52, 54, 56, 58, 60, 63 CM



SUPERSIX EVO ULTEGRA DI2

FRAME	SUPERSIX EVO BALLISTEC CARBON, DI2 SPECIFIC, SPEED SAVE
FORK	SUPERSIX EVO, SPEED SAVE, BALLISTEC CARBON
WHEELS	SHIMANO ULTEGRA 6700

MAGNESIUM WHITE W/ JET BLACK AND ULTRA BLUE ACCENTS, GLOSS (WHT)	
TIRES	SCHWALBE ULTREMO TUBELESS 700X23C
CRANKS	CANNONDALE HOLLOWGRAM SI, FSA CHAINRINGS, 50/34
DERAILLEURS	SHIMANO ULTEGRA DI2 6770

EXPOSED CARBON, GLOSS (BLK)	
SHIFTERS	SHIMANO ULTEGRA DI2 6770
BRAKES	SHIMANO ULTEGRA 6700
SIZES	48, 50, 52, 54, 56, 58, 60, 63 CM



SUPERSIX EVO 2 RED

FRAME	SUPERSIX EVO BALLISTEC CARBON, SPEED SAVE
FORK	SUPERSIX EVO, SPEED SAVE, BALLISTEC CARBON
WHEELS	MAVIC KSYRIUM EQUIPE S WTS

MAGNESIUM WHITE W/BERZERKER GREEN AND NU TEAM BLUE, GLOSS (REP)	
TIRES	MAVIC KYSION PRO 700X23C
CRANKS	SRAM S951 CARBON, BB30, 50/34
DERAILLEURS	SRAM RED

EXPOSED CARBON W/ CHARCOAL GRAY, MATTE (CRB)	
SHIFTERS	SRAM RED DOUBLETAP
BRAKES	SRAM RED
SIZES	48, 50, 52, 54, 56, 58, 60, 63 CM

SUPERSIX

> VINCITRICE PER RAZZA.

Leggera e rigida, con una sensazione incredibilmente vivace e comunicativa in sella, la SuperSix è la discendente diretta del telaio che ha portato il team Liquigas-Cannondale alla vittoria nel Giro d'Italia e nella Vuelta a España. Pronta per la competizione.



SUPERSIX 3 ULTEGRA

FRAME SUPERSIX, FULL CARBON

FORK SUPERSIX, FULL CARBON, ALLOY DROPOUTS

WHEELS MAVIC AKSIUM WTS

MAGNESIUM WHITE W/ STEALTH GRAY AND BERSERKER GREEN ACCENTS, GLOSS (WHT)

TIRES MAVIC AKSION COMP, 700X23C, FOLDING

CRANKS FSA SL-K LIGHT CARBON BB30, 50/34 (OPTION: 53/39)

DERAILLEURS SHIMANO ULTEGRA 6700

JET BLACK W/ CHARCOAL GRAY AND FINE SILVER ACCENTS, MATTE (BBQ)

SHIFTERS SHIMANO ULTEGRA 6700

BRAKES SHIMANO ULTEGRA 6700

SIZES 48, 50, 52, 54, 56, 58, 60, 63 CM

> TELAIO LEGGERO

La SuperSix pesa solo 1050 grammi e offre la guida brillante e l'accelerazione esplosiva che distingue le bici Cannondale.

> FODERI ALTI "A CLESSIDRA"

Una sottile curvatura a forma di clessidra e una raffinata stratificazione in carbonio, specifica per il carico, danno ai foderi alti della SuperSix la capacità di assorbire gli urti verticali e le vibrazioni dei fondi accidentati, migliorando sia il comfort che il controllo.

> MOVIMENTO CENTRALE BEATBOX BB / BB30

13 anni fa Cannondale ha rivoluzionato l'interfaccia pedivella/movimento centrale inventando il BB30. Qui, questo meccanismo è posizionato nella scatola movimento centrale BeatBox massicciamente sovradimensionata, per ottenere il massimo del trasferimento di potenza.



CRANK
 OPTION

SUPERSIX 5 105

FRAME	SUPERSIX, FULL CARBON
FORK	SUPERSIX, FULL CARBON, ALLOY DROPOUTS
WHEELS	SHIMANO RS-10

JET BLACK W/ CHARCOAL GRAY AND FINE SILVER ACCENTS, MATTE (BBQ)

TIRES	SCHWALBE LUGANO, 700X23C, FOLDING
CRANKS	FSA GOSSAMER PRO, BB30, 50/34 (OPTION: 50/39/30)
DERAILLEURS	SHIMANO 105 5700

MAGNESIUM WHITE W/BERZERKER GREEN AND NU TEAM BLUE, GLOSS (REP)

SHIFTERS	SHIMANO 105 5700
BRAKES	SHIMANO 105 5700
SIZES	48, 50, 52, 54, 56, 58, 60, 63 CM



> “Il telaio della SuperSix pesa appena 1050 grammi, e offre la pedalata vivace e le accelerazioni esplosive per le quali Cannondale è nota.”



CAAD10

➤ LA MACCHINA DA GARA SU STRADA IN ALLUMINIO PIÙ RAFFINATA AL MONDO.

Con un telaio che pesa solo 1.150 grammi, la CAAD10 non solo è più leggera di molti dei prestigiosi telai in carbonio della concorrenza, ma è anche più rigida e più morbida, il che la rende la scelta perfetta per aspiranti racer o per chiunque cerchi un'alternativa ad alte prestazioni al carbonio.



CAAD10 BLACK EDITION

FRAME	CAAD10, DIZ SPECIFIC, SMARTFORMED 6069 ALLOY, SPEED SAVE
FORK	CAAD10, SPEED SAVE FULL CARBON
WHEELS	SHIMANO ULTEGRA 6700

TIRES	SCHWALBE DURANO S, 700X23C, FOLDING
CRANKS	FSA SL-K LIGHT CARBON BB30, 50/34
DERAILLEURS	SHIMANO ULTEGRA DIZ

BLACK ANODIZED, GOLD, MATTE (BLA)

SHIFTERS	SHIMANO ULTEGRA DIZ
BRAKES	SHIMANO ULTEGRA 6700
SIZES	48, 50, 52, 54, 56, 58, 60, 63 CM

➤ COSTRUZIONE IN LEGA SMARTFORMED 6069

Un insieme di idroformatura, formatura meccanica, ispessimento variabile, saldature lisce a doppio passaggio e trattamento termico: SmartForming è la struttura in alluminio più avanzata al mondo, per telai più leggeri e più forti.

➤ FODERI SPEED SAVE

La forma appiattita e l'ispessimento interno dei foderi bassi e alti della CAAD10 consentono la flessione verticale, mantenendo la rigidità laterale e torsionale. Questo permette alla ruota posteriore di seguire il tracciato del terreno, migliorando la velocità, il controllo in curva, la tenuta di strada e il comfort.

➤ FORCELLA SPEED SAVE

La forcella da 390 grammi presenta un canotto sterzo conico da 1-1/8" a 1-1/4" per il bilanciamento ottimale di peso e rigidità, e forcellini in offset, che consentono un angolo più aperto della forcella e l'assorbimento degli urti senza compromettere la maneggevolezza. La forcella SPEED SAVE è adattata ottimamente ai foderi SPEED SAVE come sistema di micro sospensione.



CAAD10 3 ULTEGRA

FRAME	CAAD10, SMARTFORMED 6069 ALLOY, SPEED SAVE
FORK	CAAD10, SPEED SAVE FULL CARBON
WHEELS	MAVIC AKSIUM WTS

JET BLACK W/ MAGNESIUM WHITE AND CHARCOAL GRAY ACCENTS, MATTE (BBQ)	
TIRES	MAVIC AKSION, 700X23C, FOLDING
CRANKS	FSA SL-K LIGHT CARBON BB30, 50/34
DERAILLEURS	SHIMANO ULTEGRA 6700

BRUSHED ALUMINUM W/ JET BLACK AND MAGNESIUM WHITE ACCENTS, GLOSS (RAW)	
SHIFTERS	SHIMANO ULTEGRA 6700
BRAKES	SHIMANO ULTEGRA 6700
SIZES	48, 50, 52, 54, 56, 58, 60, 63 CM



CAAD10 5 105

FRAME	CAAD10, SMARTFORMED 6069 ALLOY, SPEED SAVE
FORK	CAAD10, SPEED SAVE FULL CARBON
WHEELS	SHIMANO RS-10

MAGNESIUM WHITE W/BERZERKER GREEN AND NU TEAM BLUE, GLOSS (REP)	
TIRES	SCHWALBE LUGANO, 700X23C, FOLDING
CRANKS	FSA GOSSAMER PRO, BB30, 50/34 (OPTION: 50/39/30)
DERAILLEURS	SHIMANO 105 5700

BRUSHED ALUMINUM W/ JET BLACK AND MAGNESIUM WHITE ACCENTS, GLOSS (RAW)	
SHIFTERS	SHIMANO 105 5700
BRAKES	SHIMANO 105 5700
SIZES	48, 50, 52, 54, 56, 58, 60, 63 CM



CAAD8 5 105

FRAME	CAAD8, OPTIMIZED 6061 ALLOY, SAVE, BB30
FORK	CANNONDALE ULTRA, CARBON BLADES
WHEELS	MADDUX RS 3.0 SPEED, 32 HOLE W/ FORMULA HUBS

BRUSHED ALUMINUM, GLOSS (RAW)	
TIRES	SCHWALBE LUGANO, 700X23C
CRANKS	FSA GOSSAMER, BB30, 50/34 (OPTION: 50/39/30)
DERAILLEURS	SHIMANO 105 5700

JET BLACK, MATTE (BBQ)	
SHIFTERS	SHIMANO 105 5700
BRAKES	TEKTRO R540, DUAL PIVOT
SIZES	48, 51, 54, 56, 58, 61 CM

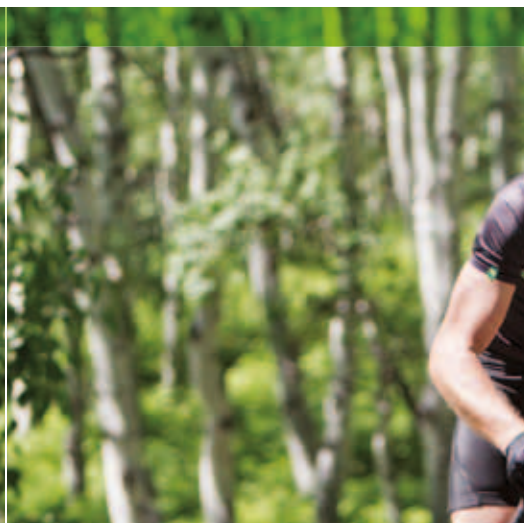

> CYCLO SPORT, JULY 2012

“Il CAAD8 ha tutto per piacere ai neofiti: un prezzo ragionevole e un telaio di alta qualità perfettamente elaborato dal marchio.”





CAAD8 6 TIAGRA

FRAME	CAAD8, OPTIMIZED 6061 ALLOY, SAVE, BB30
FORK	CANNONDALE ULTRA, CARBON BLADES
WHEELS	MADDUX RS 3.0, 32 HOLE W/ C4 HUBS

TIRES	SCHWALBE LUGANO, 700X23C
CRANKS	FSA OMEGA BB30, 50/39/30
DERAILLEURS	SHIMANO TIAGRA 4600

MAGNESIUM WHITE, GLOSS (REP)	
SHIFTERS	SHIMANO TIAGRA 4600
BRAKES	CANNONDALE C4, DUAL PIVOT
SIZES	48, 51, 54, 56, 58, 61 CM



CAAD8 7 SORA

FRAME	CAAD8, OPTIMIZED 6061 ALLOY, SAVE
FORK	CANNONDALE ULTRA, CARBON BLADES
WHEELS	MADDUX RS 3.0, 32 HOLE W/ C4 HUBS

TIRES	SCHWALBE LUGANO, 700X23C
CRANKS	FSA VERO, 50/39/30
DERAILLEURS	SHIMANO SORA

MAGNESIUM WHITE, GLOSS (WHT)	
SHIFTERS	SHIMANO SORA
BRAKES	CANNONDALE C4, DUAL PIVOT
SIZES	48, 51, 54, 56, 58, 61 CM

SYNAPSE CARBON

> LE PRESTAZIONI DA GARA ÉLITE INCONTRANO IL COMFORT DELL'USO QUOTIDIANO.

Come le migliori automobili da grand touring, la nostra linea Synapse di bici da strada unisce una performance aggressiva a un lusso raffinato. Una rigidità di livello professionale e la leggerezza del peso incontrano una morbidezza che assorbe gli urti e una posizione di guida che invita a passare intere giornate in sella. Che scegliate la Synapse Hi-MOD ultra-leggera, la Synapse Carbon dalla guida morbida o la versatile Synapse Alloy, scoprirete che andar VELOCE non ha mai dato vibrazioni tanto positive.



> SAVE PLUS SISTEMA DI MICRO-SOSPENSIONE POSTERIORI

La stratificazione direzionale del carbonio e tubi sagomati per un assorbimento eccezionale delle vibrazioni conferiscono al sistema foderi basso/foderi alto SAVE PLUS un comfort incredibile, migliorando effettivamente la rigidità laterale e torsionale del telaio.



> FORCELLA IN CARBONIO INTEGRALE SAVE PLUS

I forcellini offset consentono ai foderi della forcella di presentare l'assorbimento verticale degli urti di una forcella con rake minimale, mantenendo la guida agile e precisa della Synapse. La raffinata stratificazione del carbonio e la foggatura SAVE potenziano ulteriormente l'assorbimento verticale degli urti della forcella. Messa a punto per lavorare con il triangolo posteriore SAVE PLUS.



> GEOMETRIA PERFORMANTE

Rispetto alla nostra geometria racing di categoria Elite, la Synapse presenta un tubo sterzo di 2-2,5 cm più alto, un angolo di sterzata leggermente più aperto e un interasse più lungo, per una posizione di guida più rialzata e una sensazione stabile, ma sempre vivace. Ispira fiducia, ma anche relax, senza quella sensazione di scivolamento e la manovrabilità terribile di molte bici da strada "comfort".



SYNAPSE HI-MOD BLACK EDITION

FRAME	SYNAPSE HI-MOD FULL CARBON, SAVE PLUS
FORK	SYNAPSE SAVE PLUS, HI-MOD FULL CARBON
WHEELS	MAVIC KSYRIUM SLS

TIRES	MAVIC YKSION, GRIPLINK FRONT AND POWERLINK REAR, 700X25C, FOLDING
CRANKS	CANNONDALE HOLLOWGRAM SI SL2, CANNONDALE OPI SPIDER-ING, 50-34, 11 SPEED
DERAILLEURS	SHIMANO DURA ACE 9000

NEARLY BLACK W/MAGNESIUM WHITE, MATTE (BLE)

SHIFTERS	SHIMANO DURA ACE 9000
BRAKES	SHIMANO DURA ACE 9000
SIZES	48, 51, 54, 56, 58, 61 CM



SYNAPSE HI-MOD RED

FRAME	SYNAPSE HI-MOD FULL CARBON, SAVE PLUS
FORK	SYNAPSE SAVE PLUS, HI-MOD FULL CARBON
WHEELS	MAVIC KSYRIUM ELITE S WTS

	MAGNESIUM WHITE W/ BERSERKER GREEN, NU TEAM BLUE, GLOSS (WHT)
TIRES	MAVIC YKSION, GRIPLINK FRONT AND POWERLINK REAR, 700X25C, FOLDING
CRANKS	SRAM S951 CARBON, BB30, 50/34
DERAILLEURS	SRAM RED

	EXPOSED CARBON W/ FINE SILVER, MAGNESIUM WHITE, MATTE (BBQ)
SHIFTERS	SRAM RED DOUBLETAP
BRAKES	SRAM RED
SIZES	48, 51, 54, 56, 58, 61 CM



SYNAPSE HI-MOD 3 ULTEGRA

FRAME	SYNAPSE HI-MOD FULL CARBON, SAVE PLUS
FORK	SYNAPSE SAVE PLUS, HI-MOD FULL CARBON
WHEELS	MAVIC KSYRIUM EQUIPE S WTS

	MAGNESIUM, WHITE W/ JET BLACK AND ULTRA BLUE ACCENTS, GLOSS (BLU)
TIRES	MAVIC WTS 700X25C
CRANKS	FSA SL-K LIGHT CARBON BB30, 50/34 (OPTION: 52/39/30)
DERAILLEURS	SHIMANO ULTEGRA 6700

	EXPOSED CARBON W/ FINE SILVER, MAGNESIUM WHITE, MATTE (BBQ)
SHIFTERS	SHIMANO ULTEGRA 6700
BRAKES	SHIMANO ULTEGRA 6700
SIZES	48, 51, 54, 56, 58, 61 CM



SYNAPSE CARBON 3 ULTEGRA

FRAME	SYNAPSE, FULL CARBON, SAVE PLUS
FORK	SYNAPSE SAVE PLUS, FULL CARBON
WHEELS	MAVIC AKSIUM WTS

EXPOSED CARBON W/ 40 BLUE AND RACE RED ACCENTS, GLOSS (BLU)	
TIRES	MAVIC AKSION, 700X25C, FOLDING
CRANKS	FSA SL-K LIGHT CARBON BB30, 50/34 (OPTION: 52/39/30)
DERAILLEURS	SHIMANO ULTEGRA 6700

MAGNESIUM WHITE W/ JET BLACK, GLOSS (WHT)	
SHIFTERS	SHIMANO ULTEGRA 6700
BRAKES	SHIMANO ULTEGRA 6700
SIZES	48, 51, 54, 56, 58, 61 CM

> “Dai ciottolati del Belgio alle Gran Fondo italiane per tutto quello che c'è mezzo, la Synapse Carbon è fatta per quei ciclisti che cercano l'equilibrio tra performance aggressive e confort.”





SYNAPSE CARBON 5 105

FRAME	SYNAPSE, FULL CARBON, SAVE PLUS
FORK	SYNAPSE SAVE PLUS, FULL CARBON
WHEELS	SHIMANO RS-10

JET BLACK W/ MAGNESIUM WHITE AND CHARCOAL GRAY ACCENTS, MATTE (BBQ)	
TIRES	SCHWALBE LUGANO, 700X25C, FOLDING
CRANKS	FSA GOSSAMER PRO, BB30, 50/34 (OPTION: 50/39/30)
DERAILLEURS	SHIMANO 105 5700

EXPOSED CARBON W/ STEALTH GRAY AND ULTRA BLUE ACCENTS, GLOSS (BLU)	
SHIFTERS	SHIMANO 105 5700
BRAKES	SHIMANO 105 5700
SIZES	48, 51, 54, 56, 58, 61 CM



SYNAPSE CARBON 6 TIAGRA

FRAME	SYNAPSE, FULL CARBON, SAVE PLUS
FORK	SYNAPSE SAVE, CARBON BLADES
WHEELS	SHIMANO RS01

JET BLACK W/ BERSERKER GREEN AND MAGNESIUM WHITE ACCENTS, GLOSS (GRN)	
TIRES	SCHWALBE LUGANO, 700X25C
CRANKS	FSA OMEGA, BB30, 50/39/30
DERAILLEURS	SHIMANO TIAGRA 4600

JET BLACK W/ BERSERKER GREEN AND MAGNESIUM WHITE ACCENTS, GLOSS (GRN)	
SHIFTERS	SHIMANO TIAGRA 4600
BRAKES	SHIMANO TIAGRA 4600
SIZES	48, 51, 54, 56, 58, 61 CM



SYNAPSE ALLOY 105

FRAME	SYNAPSE ALLOY, OPTIMIZED 6061 ALLOY, SAVE PLUS, BB30
FORK	SYNAPSE SAVE, CARBON BLADES
WHEELS	SHIMANO RS10

TIRES	SCHWALBE LUGANO, 700X25C
CRANKS	FSA GOSSAMER, BB30, 50/39/30
DERAILLEURS	SHIMANO 105 5700

MAGNESIUM WHITE, GLOSS (WHT)

SHIFTERS	SHIMANO 105 5700
BRAKES	SHIMANO BR-560, DUAL PIVOT, LONG REACH
SIZES	48, 51, 54, 56, 58, 61 CM



SYNAPSE ALLOY TIAGRA

FRAME	SYNAPSE ALLOY, OPTIMIZED 6061 ALLOY, SAVE PLUS, BB30
FORK	SYNAPSE SAVE, CARBON BLADES
WHEELS	MADDUX RS 3.0, 32 HOLE W/ C4 HUBS

TIRES	SCHWALBE LUGANO, 700X25C
CRANKS	FSA OMEGA, BB30, 50/39/30
DERAILLEURS	SHIMANO TIAGRA 4600

JET BLACK, MATTE (BBQ)

SHIFTERS	SHIMANO TIAGRA 4600
BRAKES	SHIMANO BR-451, DUAL PIVOT, LONG REACH
SIZES	48, 51, 54, 56, 58, 61 CM

SLICE RS

> STRETTO È AERO – NARROW IS AERO™

La Slice RS è l'arma definitiva nella gara contro il tempo. Ogni dettaglio della bicicletta, dalla forcella radicale senza tubo di sterzo ai freni aereodinamici fino al tubo reggisella ultra minimalista, è studiato per essere il più sottile possibile, riducendo la resistenza e consentendo a bicicletta e rider di fendere morbidamente l'aria. Aggiungete caratteristiche come il nostro sistema anti vibrazioni AERO SAVE, il nostro sistema di adattamento modulare CFit e avrete una macchina che taglia il tempo, confortevole come è la aero.

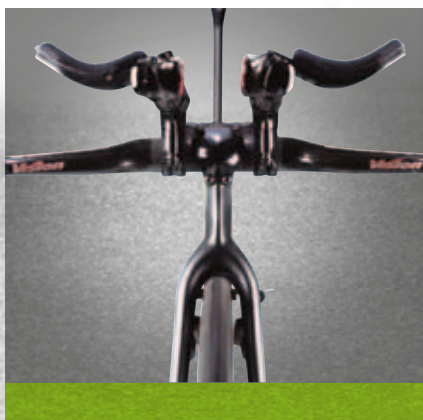

> STRETTO È AERO – NARROW IS AERO™

La forcella del tubo di sterzo esterno e il tubo reggisella Naero-Tec aiutano la Slice RS a opporre al vento un'area frontale di dimensione assolutamente minima. La struttura è anche estremamente rigida, per una precisione di manovrabilità senza eguali.



> FRENI A CONO DI SVENTAMENTO

I freni integrati sono nascosti nel cono di sventamento della forcella e del movimento centrale. La struttura modificata dei freni a V è semplice da regolare e offre tonnellate di potenza frenante.

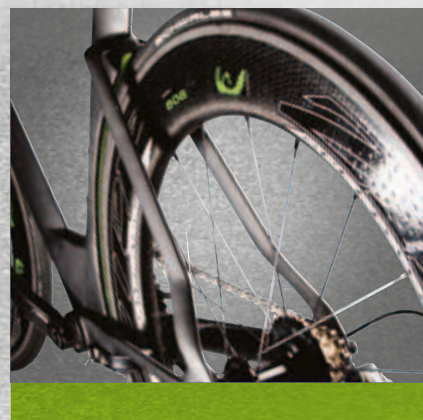

> SISTEMA ANTI VIBRAZIONE AERO SAVE / WINDTUNNEL

La stratificazione del carbonio e le forme angolate dei foderi alti AERO SAVE interagiscono con i foderi bassi Naero Plane per assorbire gli urti, riducendo l'affaticamento e ottimizzando il controllo. Il canale WindTunnel dietro al tubo verticale riduce la resistenza aerodinamica da pressione causata dall'aria che si ferma tra la ruota in movimento e il telaio.



SLICE RS BLACK EDITION

FRAME	SLICE RS, FULL CARBON, AERO SAVE, NAERO-TEC
FORK	SLICE RS NAERO-TEC CARBON W/ INTEGRATED EXTERNAL STEERER
WHEELS	ZIPP 808 FIRECREST TUBULAR

TIRES	SCHWALBE ULTRAMO HT TUBULAR 700X22C
CRANKS	CANNONDALE HOLLOWGRAM SISL2, AERO SPIDER, 54/42
DERAILLEURS	SRAM RED

NEARLY BLACK W/ BERSERKER GREEN, MATTE (BLE)

SHIFTERS	SRAM RED
BRAKES	CANNONDALE NAERO-TEC INTEGRATED MINI-V, CARBON ARMS
SIZES	50,52,54,56,58 CM



SLICE RS ULTEGRA DI2

FRAME	SLICE RS, FULL CARBON, AERO SAVE, NAERO-TEC
FORK	SLICE RS NAERO-TEC CARBON W/ INTEGRATED EXTERNAL STEERER
WHEELS	VISION TRIMAX T42

TIRES	SCHWALBE ULTREMO ZX 700X23C
CRANKS	FSA TRIMAX CARBON RINGS, BB30
DERAILLEURS	SHIMANO ULTEGRA DI2

MAGNESIUM WHITE W/ JET BLACK AND RACE RED, GLOSS (WHT)

SHIFTERS	SHIMANO ULTEGRA DI2
BRAKES	CANNONDALE NAERO-TEC INTEGRATED MINI-V
SIZES	50,52,54,56,58 CM



SLICE RS ULTEGRA

FRAME	SLICE RS, FULL CARBON, AERO SAVE, NAERO-TEC
FORK	SLICE RS NAERO-TEC CARBON W/ INTEGRATED EXTERNAL STEERER
WHEELS	MAVIC COSMIC ELITE

TIRES	SCHWALBE DURANO S, 700X23C, FOLDING
CRANKS	FSA TRIMAX ALLOY RINGS, BB30
DERAILLEURS	SHIMANO ULTEGRA 6700

MAGNESIUM WHITE W/ JET BLACK AND RACE RED, GLOSS (WHT)

SHIFTERS	SHIMANO DURA-ACE, BAR-END
BRAKES	CANNONDALE NAERO-TEC INTEGRATED MINI-V
SIZES	50,52,54,56,58 CM



SLICE HI-MOD RED

FRAME	SLICE, HI-MOD CARBON, AERO SAVE
FORK	SLICE AERO, HI-MOD CARBON
WHEELS	FULCRUM RACING 7

TIRES	SCHWALBE DURANO S, 700X23C, FOLDING
CRANKS	NEW CANNONDALE HOLLOWGRAM SI, FSA CHAINRINGS, 53/39T
DERAILLEURS	SRAM RED

COLORS	MARINER BLUE W/ RACE RED AND 40 BLUE ACCENTS, GLOSS (BLU)
SHIFTERS	SRAM TT 900 CARBON
BRAKES	MAGURA RT-6 TT HYDRAULIC CALIPER
SIZES	51, 54, 56, 58, 60 CM





SLICE ULTEGRA

FRAME	SLICE, FULL CARBON, AERO SAVE
FORK	SLICE AERO, FULL CARBON
WHEELS	FULCRUM RACING 7

TIRES	SCHWALBE LUGANO, 700X23C, FOLDING
CRANKS	FSA GOSSAMER TT, BB30, 52/38
DERAILLEURS	SHIMANO ULTEGRA 6700

MAGNESIUM WHITE W/ PROCESS CYAN, GLOSS (WHT)

SHIFTERS	SHIMANO DURA-ACE, BAR-END
BRAKES	SHIMANO ULTEGRA 6700
SIZES	51, 54, 56, 58, 60 CM



SLICE 105

FRAME	SLICE, FULL CARBON, AERO SAVE
FORK	SLICE AERO, FULL CARBON
WHEELS	SHIMANO RS-10

TIRES	SCHWALBE LUGANO, 700X23C
CRANKS	FSA GOSSAMER PRO, BB30, 53/39
DERAILLEURS	SHIMANO 105 5700

JET BLACK W/ CHARCOAL GRAY, MATTE (BBQ)

SHIFTERS	MICROSHIFT BAR-END
BRAKES	SHIMANO 105 5700
SIZES	51, 54, 56, 58, 60 CM

SUPERX

SEMPLICEMENTE LA MACCHINA DA CYCLOCROSS PIÙ AVANZATA AL MONDO.

La SuperX è più leggera della maggior parte delle road bike, ineguagliata nel rapporto rigidità-peso e più fluida di una birra belga. Nulla accelera più rapidamente, curva con maggiore durezza o è più facile da caricare in spalla della SuperX – l'arma da gara definitiva per quelli che vivono per combattere nel glorioso fango ghiacciato del cyclocross.



SUPERX HI-MOD DISC

FRAME SUPERX DISC, BALLISTEC HI-MOD CARBON, SPEED SAVE

FORK SUPERX, BALLISTEC HI-MOD CARBON

WHEELS STANS ALPHA 340 DISC, TUBELESS, 24H FRONT, 28H REAR

TIRES SCHWALBE RACING RALPH 700X33C

CRANKS FSA SL-K LIGHT CARBON BB30, 46/36

DERAILLEURS SRAM RED

JET BLACK W/ BERSERKER GREEN (GLOSS) (GRN)

SHIFTERS SRAM RED DOUBLETAP

BRAKES AVID BB7 ULTIMATE

SIZES 44, 48, 52, 54, 56, 58 CM

BALLISTEC CARBON

La nostra struttura in carbonio ad alta resistenza e ad alto impatto prova che i telai in carbonio possono essere sia ultraleggeri che super-duraturi. SuperX è disponibile sia nell'opzione in carbonio BallisTec ad alto modulo di una leggerezza pazzesca, che nella versione leggera standard semplicemente straordinaria.

TECNOLOGIA DI SOPPRESSIONE DELLE VIBRAZIONI SPEED SAVE

Sezioni trasversali appiattite e una sofisticata stratificazione del carbonio consentono alle caratteristiche SPEED SAVE di agire come un sistema di micro-sospensione, deflettendo verticalmente per assorbire gli urti e le vibrazioni del fondo stradale, pur rimanendo estremamente rigide lateralmente per il trasferimento della forza e per manovre sicure in curva.

FRENI A DISCO

Per la prima volta l'eccezionale performance della SuperX nel cyclocross sarà disponibile con potenza d'arresto in qualsiasi condizione meteo, espulsione del fango e modulazione controllata dei freni a disco.



SUPERX HI-MOD DI2 ULTEGRA

FRAME	SUPERX, DI2 SPECIFIC, BALLISTEC HI-MOD CARBON, SPEED SAVE
FORK	SUPERX, BALLISTEC HI-MOD CARBON
WHEELS	SHIMANO ULTEGRA 6700 TUBELESS

TIRES	SCHWALBE RACING RALPH 700X33C
CRANKS	FSA SL-K LIGHT CARBON BB30, 46/36
DERAILLEURS	SHIMANO ULTEGRA DI2

JET BLACK W/ BERSERKER GREEN, GLOSS (GRN)

SHIFTERS	SHIMANO ULTEGRA DI2
BRAKES	TRP EURO-X ALLOY
SIZES	44, 48, 52, 54, 56, 58 CM



SUPERX ULTEGRA

FRAME	SUPERX, BALLISTEC CARBON, SPEED SAVE
FORK	SUPERX, BALLISTEC CARBON
WHEELS	MAVIC KSYRIUM EQUIPE

TIRES	SCHWALBE RAPID ROB, 700X35C
CRANKS	FSA GOSSAMER PRO, BB30, 46/36
DERAILLEURS	SHIMANO ULTEGRA 6700

MAGNESIUM WHITE W/ JET BLACK, GLOSS (WHT)

SHIFTERS	SHIMANO ULTEGRA 6700
BRAKES	TRP EURO-X ALLOY
SIZES	44, 48, 52, 54, 56, 58 CM



> **TIM JOHNSON**

“È una bici innovativa che fa uscire le bici da cross dagli anni ,60. La SuperX Disc sposa le migliori tecnologie del carbonio con il cyclocross. Con I freni a disco è una leggera, veloce e rigida macchina per vincere“ .



SUPERX RIVAL

FRAME	SUPERX, BALLISTEC CARBON, SPEED SAVE
FORK	SUPERX, BALLISTEC CARBON
WHEELS	FULCRUM RACING 7 CX

TIRES	SCHWALBE RAPID ROB, 700X35C
CRANKS	FSA GOSSAMER PRO, BB30, 46/36
DERAILLEURS	SRAM RIVAL

MAGNESIUM WHITE W/ JET BLACK, GLOSS (WHT)

SHIFTERS	SRAM RIVAL DOUBLETAP
BRAKES	TRP EURO-X ALLOY
SIZES	44, 48, 52, 54, 56, 58 CM



CAADX DISC ULTEGRA

FRAME	CAADX CYCLOCROSS DISC, OPTIMIZED 6061 ALLOY, BB30
FORK	CANNONDALE ULTRA X, CARBON BLADES
WHEELS	MADDUX CX 2.0 DISC W/ FORMULA HUBS

TIRES	SCHWALBE SAMMY SLICK, 700X35C
CRANKS	FSA GOSSAMER PRO, BB30, 46/36
DERAILLEURS	SHIMANO ULTEGRA 6700

BLACK ANODIZED (BLA)

SHIFTERS	SHIMANO ULTEGRA 6700
BRAKES	CANNONDALE MB700T DISC
SIZES	44, 48, 51, 54, 56, 58, 61 CM





CAADX 105

FRAME	CAADX CYCLOCROSS, OPTIMIZED 6061 ALLOY, BB30
FORK	CANNONDALE ULTRA X, CARBON BLADES
WHEELS	MADDUX DRX 6000, 32 HOLE W/ FORMULA HUBS

TIRES	SCHWALBE SAMMY SLICK, 700X35C
CRANKS	FSA GOSSAMER, BB30, 46/36
DERAILLEURS	SHIMANO 105 5700

BRUSHED ALUMINUM, GLOSS (RAW)	
SHIFTERS	SHIMANO 105 5700
BRAKES	TEKTRO CR710
SIZES	44, 48, 51, 54, 56, 58, 61 CM



CAADX TIAGRA

FRAME	CAADX CYCLOCROSS, OPTIMIZED 6061 ALLOY, BB30
FORK	CANNONDALE ULTRA X, CARBON BLADES
WHEELS	MADDUX DRX 6000, 32 HOLE W/ C4 HUBS

TIRES	SCHWALBE SAMMY SLICK, 700X35C
CRANKS	FSA OMEGA BB30, 46/36
DERAILLEURS	SHIMANO TIAGRA 4600

JET BLACK, MATTE (BBQ)	
SHIFTERS	SHIMANO TIAGRA 4600
BRAKES	TEKTRO CR520
SIZES	44, 48, 51, 54, 56, 58, 61 CM

URBAN

CANNONDALE RECREATION / URBAN

La nostra passione è creare l'assetto di guida perfetto per ogni tipo di rider. Le prestazioni elevate, le caratteristiche di adattamento e lo stile delle nostre biciclette Recreation e Urban vi saranno di ispirazione per restare più in forma, muoversi tra casa a lavoro e passare più tempo sulle due ruote.

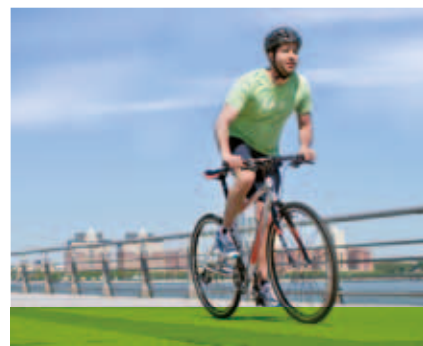
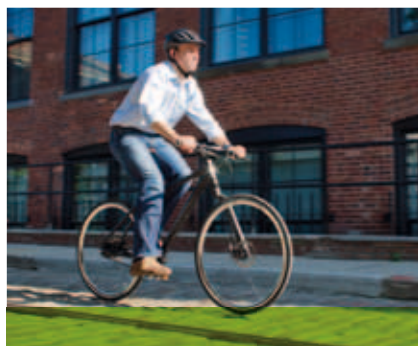

> E-SERIES

E-SERIES WOMEN'S
E-SERIES MEN'S

E-SERIES / E-SERIES WOMEN'S: Velocità resa davvero semplice. La popolare soluzione di mobilità urbana elettroassistita.

> STREET

BAD BOY
BAD GIRL
HOOLIGAN

BAD BOY / BAD GIRL: Trasporto urbano sobrio, stiloso, high-tech.

HOOLIGAN: Un modo divertente, «funky» e funzionale per muoversi in città.

> RECREATION

QUICK SPEED
QUICK CX
TESORO

QUICK SPEED / QUICK SPEED WOMEN'S: La velocità e l'agilità di una bici da strada con il comfort di una posizione sportiva verticale.

QUICK CX / QUICK CX MIXTE: L'efficienza su strada incontra la resistenza off-road per adventuring, guida su fondi misti e commuting.

TESORO: Super commuter a pieno carico.



E-SERIES

> PURA EFFICIENZA.

Intuitiva, potente e facile, la E-Series è progettata per chiunque si concentri sulle prestazioni. Dotata della coppia motrice migliore in assoluto, di un'erogazione ultra-morbida, di un peso straordinariamente leggero e di una impareggiabile System Integration, la E-Series di Cannondale preannuncia una nuova era del ciclismo.



E-SERIES WOMEN'S ALFINE 8

FRAME	E-SERIES SI HEADSHOK, WOMEN'S SPECIFIC W/ INTEGRATED RACK
FORK	HEADSHOK FATTY DL50, 50MM W/LOCKOUT, (DL50 XL FOR SIZE 50, 55)
TIRES	SCHWALBE MARATHON SUPREME 700X35C

JET BLACK, MATTE (BBQ)

CRANKS	FSA METROPOLIS, BOSCH SPECIFIC
DERAILLEURS R/F	N/A
SHIFTERS	SHIMANO ALFINE 8

MAGNESIUM WHITE, GLOSS (WHT)

HANDLEBAR/STEM	CANNONDALE TREKKING / C3 ADJUSTABLE
BRAKES	MAGURA MT2 HYDRAULIC DISC, 160/160MM
SIZES	45, 50, 55

> MAESTRIA CANNONDALE CON L'ALLUMINIO

La leggendaria maestria Cannondale con l'alluminio. Saldature estremamente lisce, attacchi interni conici e lineari, tubi idroformati e l'innovativo puntone del portapacchi del tubo verticale suddiviso con instradamento interno dei cavi contraddistinguono la E-Series.

> PORTAPACCHI/SUPPORTO BATTERIA INTEGRATO

Il portapacchi dai colori abbinati visivamente elegante e lineare integra il supporto della batteria con cavi nascosti, parafango/supporto luci e pompa. Stabile, sicuro e comodo.

> LUCCHETTO BLOCCA - RUOTA POSTERIORE INTEGRATO E SI KICKSTAND

Facile da usare, il blocco ruote posteriore di colore abbinato utilizza la stessa chiave del blocco batteria. Così semplice, pulito e sicuro quando si lascia la bicicletta incustodita. Il Si Kickstand integrato montato posteriormente è stabile, visivamente e funzionalmente integrato: un dettaglio innovativo.



► SISTEMA DI TRASMISSIONE BOSCH A INSTALLAZIONE CENTRALE

Cannondale ha collaborato con Bosch per un periodo di oltre due anni per sviluppare questo rivoluzionario sistema di trasmissione. Il design con installazione centrale assicura una distribuzione ottimale del peso, la massima efficienza e la migliore coppia in assoluto. I sensori misurano richiesta e velocità duecento volte al secondo per garantire che la potenza venga erogata con una morbidezza perfetta in tutte le situazioni.



► COMANDI SEMPLICI E INTUITIVI

Il sistema offre quattro diversi livelli di assistenza, ECO, Tour, SPORT e SPEED per adattarsi alle tue esigenze in sella. I comandi montati al manubrio ti consentono di passare facilmente da una modalità all'altra, senza dover spostare le mani.



► PRESTAZIONI MIGLIORI GRAZIE ALLA SYSTEM INTEGRATION

La nostra forcella integrata HeadShok DL50 è ultraleggera e scorre su cuscinetti ad aghi per una morbidezza e una precisione di sterzo impareggiabili. La batteria a rilascio rapido si integra senza soluzione di continuità nel portapacchi posteriore, per un aspetto sobrio ed elegante.



E-SERIES MEN'S ALFINE 8

FRAME	E-SERIES SI HEADSHOK, MEN'S SPECIFIC W/ INTEGRATED RACK
FORK	HEADSHOK FATTY DL50, 50MM W/LOCKOUT, (DL50 XL FOR SIZE 55, 60)
TIRES	SCHWALBE MARATHON SUPREME 700X35C

CRANKS	FSA METROPOLIS, BOSCH SPECIFIC
DERAILLEURS R/F	I/A
SHIFTERS	SHIMANO ALFINE 8

JET BLACK, MATTE (BBQ)

HANDLEBAR/STEM	CANNONDALE TREKKING / C3 ADJUSTABLE
BRAKES	MAGURA MT2 HYDRAULIC DISC, 160/160MM
SIZES	50, 55, 60



E-SERIES MEN'S

FRAME	E-SERIES SI HEADSHOK, MEN'S W/ INTEGRATED RACK
FORK	HEADSHOK FATTY DL50, 50MM W/LOCKOUT
TIRES	SCHWALBE MARATHON SUPREME 700X35C

CRANKS	FSA METROPOLIS, BOSCH SPECIFIC
DERAILLEURS R/F	SHIMANO SLX / N/A
SHIFTERS	SHIMANO DEORE

JET BLACK, MATTE (BBQ)

HANDLEBAR/STEM	CANNONDALE TREKKING / C3 ADJUSTABLE
BRAKES	MAGURA MT2 HYDRAULIC DISC, 160/160MM
SIZES	50, 55, 60



E-SERIES WOMEN'S

FRAME	E-SERIES SI HEADSHOK, WOMEN'S W/ INTEGRATED RACK
FORK	HEADSHOK FATTY DL50, 50MM W/LOCKOUT
TIRES	SCHWALBE MARATHON SUPREME 700X35C

CRANKS	FSA METROPOLIS, BOSCH SPECIFIC
DERAILLEURS R/F	SHIMANO SLX / N/A
SHIFTERS	SHIMANO DEORE

JET BLACK, MATTE (BBQ)

HANDLEBAR/STEM	CANNONDALE TREKKING / C3 ADJUSTABLE
BRAKES	MAGURA MT2 HYDRAULIC DISC, 160/160MM
SIZES	45, 50, 55



> CANNONDALE E-SERIES.

E-Bike dell'anno 2012.



E-Bike van het Jaar 2012
E-bike van het Jaar 2012



BAD BOY

> URBANE LEGENDE.

Come un caccia stealth con ruote 700c, la Bad Boy è un modo rapido, stiloso, funzionale e high-tech per spostarsi in città. Più veloce della metropolitana, più trendy di un taxi, Bad Boy aggiunge un pizzico di brivido anticonformista a ogni spostamento urbano.



> OPZIONI FORCELLA UNICHE

La HeadShok Solo DL50, dal look radicale, leggerissima e monofodero, offre 50 mm di corsa fluida, smorzamento idraulico e un comodo bloccaggio, mentre le forcelle rigide non-suspension Solo o Fatty sono superleggere e precise.



> GEOMETRIA SU MISURA

Non sorprende quindi che, nella sua geometria urbana, Bad Boy abbia un'inclinazione un po' più aggressiva della media. La sua posizione e i suoi angoli forniscono una rapida reattività, mantenendo una buona visibilità al rider nel traffico.



> FODERI BASSI SAVE

I foderi bassi dalla forma ottimizzata aggiungono l'assorbimento verticale degli urti e comfort senza compromettere il trasferimento della forza.



BAD BOY 0 ALFINE 11

FRAME	BAD BOY STEALTH, HEADSHOK, EBB
FORK	HEADSHOK SOLO DL50, 50MM W/LOCKOUT, OPI
TIRES	SCHWALBE KOJAK RACE GUARD, 700X28C

CRANKS	TRUVATIV FIREX, 42T
DERAILLEURS R/F	N/A
SHIFTERS	SHIMANO ALFINE 11 RAPIDFIRE PLUS

BLACK ANODIZED W/REFLECTIVE DECALS, MATTE (BBQ)

HANDLEBAR/STEM	URBAN OPI STEM/HANDLEBAR W/ SJ LIGHT
BRAKES	MAGURA MT2 HYDRAULIC DISC
SIZES	S, M, L, X



BAD BOY 2 SLX

FRAME	BAD BOY STEALTH, HEADSHOK, OPTIMIZED 6061 ALLOY
FORK	HEADSHOK FATTY DL50, 50MM W/LOCKOUT, OPI
TIRES	SCHWALBE KOJAK RACE GUARD, 700X28C

CRANKS	SHIMANO DEORE, 42/32/24
DERAILLEURS R/F	SHIMANO SLX / DEORE
SHIFTERS	SHIMANO DEORE

BLACK ANODIZED W/REFLECTIVE DECALS, MATTE (BBQ)

HANDLEBAR/STEM	URBAN OPI STEM/HANDLEBAR W/ SI LIGHT
BRAKES	MAGURA MT2 HYDRAULIC DISC
SIZES	S, M, L, X



BAD BOY 4 DEORE

FRAME	BAD BOY, 1.5" HT, OPTIMIZED 6061 ALLOY
FORK	CANNONDALE FATTY RIGID OPI, 1.5"
TIRES	SCHWALBE KOJAK RACE GUARD, 700X28C

CRANKS	SHIMANO DEORE, 48/36/26
DERAILLEURS R/F	SHIMANO SLX / DEORE
SHIFTERS	SHIMANO DEORE

JET BLACK W/REFLECTIVE DECALS, MATTE (BBQ)

HANDLEBAR/STEM	URBAN OPI STEM/HANDLEBAR W/ SI LIGHT
BRAKES	MAGURA MT2 HYDRAULIC DISC
SIZES	S, M, L, X



BAD BOY 6 ALIVIO

FRAME BAD BOY, OPTIMIZED 6061 ALLOY

FORK *CANNONDALE FATTY RIGID, 26**

TIRES SCHWALBE KOJAK RACE GUARD, 700X28C

CRANKS SHIMANO M431, BAD BOY, 48/36/26

DERAILLEURS R/F SHIMANO DEORE / ACERA

SHIFTERS SHIMANO ACERA

JET BLACK W/REFLECTIVE DECALS, MATTE (BBQ)

HANDLEBAR/STEM CANNONDALE C4

BRAKES SHIMANO M395 HYDRAULIC DISC

SIZES S, M, L, X

> “Molto di più che una semplice urban-bike, la Badboy è una urban-legend.”





BAD BOY 7 26"

FRAME	"BAD BOY 26", OPTIMIZED 6061 ALLOY"
FORK	"CANNONDALE FATTY RIGID, 26"
TIRES	"SCHWALBE KOJAK RACE GUARD, 26X2.0"

CRANKS	SHIMANO ACERA 48/36/26
DERAILLEURS R/F	SHIMANO ACERA
SHIFTERS	SHIMANO ACERA

JET BLACK W/REFLECTIVE DECALS, MATTE (BBQ)

HANDLEBAR/STEM	CANNONDALE C4
BRAKES	CANNONDALE C4 V-BRAKE
SIZES	S, M, L, X



BAD GIRL 2

FRAME	BAD GIRL, OPTIMIZED 6061 ALLOY
FORK	CANNONDALE FATTY RIGID
TIRES	FREEDOM THICK SLICK, 700X28C

CRANKS	FSA VERO SINGLE SPEED, 42
DERAILLEURS R/F	SHIMANO DEORE / N/A
SHIFTERS	SHIMANO DEORE

JET BLACK W/REFLECTIVE DECALS, MATTE (BBQ)

HANDLEBAR/STEM	CANNONDALE C3
BRAKES	CANNONDALE HELIX 6 HYDRAULIC DISC, 160/160MM
SIZES	S, T



> “Alla moda, funzionale e veloce, la BadGirl è una vetrina di rapida tecnologia e design affilato che si fa notare ovunque.”



HOOLIGAN 1

FRAME	NEW HOOLIGAN DELTA V, URBAN COMPACT, 20" WHEEL
SUSPENSION, R/F	CANNONDALE SOLO RIGID, OPI, 1.5"
WHEELS	KENDA QUEST, 20 X 1.5"

CRANKS	FSA VERO, SINGLE RING, DUAL ALLOY CHAINGUARD, 48T
DERAILLEURS, R/F	N/A
SHIFTERS	SHIMANO NEXUS REVO 3-SPEED

JET BLACK, MATTE (BBQ)

BRAKES	CANNONDALE URBAN / C3 ADJUSTABLE
TIRES	SHIMANO M375 MECHANICAL DISC, 160/160MM
SIZES	ONE SIZE

QUICK SPEED

> CONFORTEVOLMENTE VELOCE.

Seguendo il percorso del tour attraverso i Pirenei o passando da un caffè all'altro sulla Costiera Amalfitana, lasciate che i chilometri scorrano via mentre vi godete il panorama. La Quick SPEED coniuga la velocità e l'agilità di una bici da strada con una posizione eretta sportiva e la versatilità degli pneumatici 700x28c. Se un «credit card tour» è la vostra idea di vacanza alla grande, o semplicemente al mattino vi piace prendere la strada più lunga per andare al lavoro, la Quick Speed è una compagna perfetta.



> GEOMETRIA SU MISURA DEL RIDER: QUICK

Per le Quick "geometria su misura del rider" significa equilibrio tra una posizione sportiva ed efficiente e la comodità e il comfort della guida ad assetto rialzato.



> FORCELLE SU MISURA

Ogni Quick è abbinata a una forcella Cannondale specificamente progettata per il telaio, per un look inimitabile e un'eccezionale guidabilità.



> CARATTERISTICHE DI COMFORT

Tutte le Quick hanno caratteristiche SAVE nel triangolo posteriore per assorbire gli urti, pedali piani soft-grip e manopole e sella ergonomiche per il massimo comfort.



QUICK SPEED 1 CARBON

FRAME	QUICK FULL CARBON, W/ SAVE FEATURES
FORK	QUICK FULL CARBON SI
TIRES	SCHWALBE MARATHON SUPREME, 700X28C

CRANKS	FSA SL-K, BB30, 50/34
DERAILLEURS R/F	SHIMANO ULTEGRA
SHIFTERS	SHIMANO RL-770

BLACK CARBON (MATTE)

HANDLEBAR/STEM	CANNONDALE C2
BRAKES	TEKTRO TRP CX9
SIZES	46, 51, 57



QUICK SPEED 2 105/WOMEN'S

FRAME	QUICK SL, OPTIMIZED 6061 ALLOY, SAVE
FORK	QUICK SI, CARBON BLADES, W/ LOW RIDER MOUNTS
TIRES	SCHWALBE MARATHON SUPREME, 700X28C

CRANKS	SHIMANO 105 5700, 50/34
DERAILLEURS R/F	SHIMANO 105 5700
SHIFTERS	SHIMANO TIAGRA 4600 FLATBAR

HANDLEBAR/STEM	CANNONDALE C2 / C3
BRAKES	CANNONDALE C2 MINI V, CARTRIDGE PADS
SIZES	MEN'S: 48, 52, 56, 60 CM / WOMEN'S 42, 46, 52 CM



QUICK SPEED 3 NEXUS/WOMEN'S

FRAME	QUICK SL, EBB, OPTIMIZED 6061 ALLOY
FORK	QUICK SI, CARBON BLADES, W/ LOW RIDER MOUNTS
TIRES	SCHWALBE MARATHON SUPREME, 700X28C

CRANKS	TRUVATIV FIREX 1.1G, 42T
DERAILLEURS R/F	N/A
SHIFTERS	SHIMANO NEXUS 8-SPEED

HANDLEBAR/STEM	CANNONDALE C3 / FSA VARIUS ADJUSTABLE
BRAKES	CANNONDALE C2 MINI V, CARTRIDGE PADS
SIZES	MEN'S: 48, 52, 56, 60 CM / WOMEN'S 42, 46, 52 CM



QUICK SPEED 4 TIAGRA/WOMEN'S

FRAME	QUICK SL, OPTIMIZED 6061 ALLOY, SAVE
FORK	QUICK SL, CARBON BLADES, W/ LOW RIDER MOUNTS
TIRES	SCHWALBE MARATHON SUPREME, 700X28C

FRAME	JET BLACK, MATTE (BBQ)
CRANKS	SHIMANO TIAGRA, 50/34
DERAILLEURS R/F	SHIMANO TIAGRA
SHIFTERS	SHIMANO TIAGRA 4600 FLATBAR

FRAME	MAGNESIUM WHITE, GLOSS (WHT) WOMEN'S
HANDLEBAR/STEM	CANNONDALE C3
BRAKES	CANNONDALE C2 MINI V, CARTRIDGE PADS
SIZES	MEN'S: 48, 52, 56, 60 CM / WOMEN'S 42, 46, 52 CM





QUICK CX 1

FRAME	QUICK CX, OPTIMIZED 6061 ALLOY, SAVE, HEADSHOK
FORK	HEADSHOK FATTY DL50, 50MM W/LOCKOUT, OPI
TIRES	SCHWALBE SAMMY SLICK, 700X35C

BRUSHED ALUMINUM, GLOSS (RAW)	
CRANKS	SHIMANO SLX, 42/32/22
DERAILLEURS R/F	SHIMANO XT / SLX
SHIFTERS	SHIMANO SLX

BRUSHED ALUMINUM, GLOSS (RAW) MIXTE	
HANDLEBAR/STEM	CANNONDALE C3
BRAKES	MAGURA MT4 HYDRAULIC DISC
SIZES	MEN'S: 48, 52, 56, 60 CM / MIXTE: 48, 53, 55



QUICK CX 2/MIXTE

FRAME	QUICK CX, OPTIMIZED 6061 ALLOY, SAVE
FORK	RST NEON PLS 1.5" TNL, 50MM W/LOCKOUT
TIRES	SCHWALBE SAMMY SLICK, 700X35C

MAGNESIUM WHITE, GLOSS (WHT)	
CRANKS	SHIMANO DEORE M591, 48/36/26
DERAILLEURS R/F	SHIMANO SLX / DEORE
SHIFTERS	SHIMANO DEORE

MAGNESIUM WHITE, GLOSS (WHT) MIXTE	
HANDLEBAR/STEM	CANNONDALE C4
BRAKES	MAGURA MT2 HYDRAULIC DISC
SIZES	MEN'S: 48, 52, 56, 60 CM / MIXTE: 48, 53, 55



QUICK CX 3/MIXTE

FRAME	QUICK CX, OPTIMIZED 6061 ALLOY, SAVE
FORK	RST NEON PLS 1.5" MNL, 50MM W/LOCKOUT
TIRES	SCHWALBE SAMMY SLICK, 700X35C

JET BLACK, MATTE (BBQ)	
CRANKS	SHIMANO ACERA M391, 48/36/26
DERAILLEURS R/F	SHIMANO DEORE / ACERA
SHIFTERS	SHIMANO ACERA

JET BLACK, MATTE (BBQ) MIXTE	
HANDLEBAR/STEM	CANNONDALE C3
BRAKES	TEKTRO 855 V-BRAKE
SIZES	MEN'S: 48, 52, 56, 60 CM / MIXTE: 48, 53, 55



QUICK CX 4/MIXTE

FRAME	QUICK CX RIGID, OPTIMIZED 6061 ALLOY, SAVE
FORK	FATTY RIGID DISC, ALLOY
TIRES	SCHWALBE SAMMY SLICK, 700X35C

STEALTH GREY, MATTE (GRY)	
CRANKS	SHIMANO M171 48/38/28
DERAILLEURS R/F	SHIMANO ACERA / ALIVIO
SHIFTERS	SHIMANO ALTUS

STEALTH GREY, MATTE (GRY) MIXTE	
HANDLEBAR/STEM	CANNONDALE C4
BRAKES	TEKTRO 855 V-BRAKE
SIZES	MEN'S: 48, 52, 56, 60 CM / MIXTE: 48, 53, 55

TESORO/MIXTE

> PERFORMANCE A PIENO CARICO.

In un mondo pieno di pesanti e lenti cavalli da lavoro urbani, Tesoro è un vivace purosangue. Completamente equipaggiata con parafango, portapacchi, luci e manubrio arretrato, la sensazione di elevata performance e la precisione della manovrabilità di questa super-commuter sono caratteristiche tutte Cannondale.



> PERFETTAMENTE EQUIPAGGIATA

I modelli Tesoro vengono forniti già equipaggiati di parafanghi di categoria premium, portapacchi posteriori, lucchetto alla ruota, affidabili generatori per i fari e cavalletti, per nominare solo alcuni accessori.



> MAESTRIA CANNONDALE CON L'ALLUMINIO

La nostra esperienza trentennale nella lavorazione dell'alluminio è evidente nelle forme eleganti dei tubi e nelle saldature lisce a doppio passaggio della Tesoro.



> COCKPIT CONFORTEVOLE

Un attacco del manubrio facilmente regolabile, e il manubrio ribassato su misura consentono al rider di trovare la "giusta posizione".



TESORO 0 ALFINE 11/MIXTE

FRAME	TESORO SI, HEADSHOK, OPTIMIZED 6061 ALLOY, SAVE, EBB
FORK	HEADSHOK FATTY DL50, 50MM W/LOCKOUT, OPI
TIRES	SCHWALBE MARATHON SUPREME, 700X35C

BRUSHED ALUMINUM, GLOSS (RAW) MIXTE

CRANKS	TRUVATIV FIREX, 42T
DERAILLEURS R/F	N/A
SHIFTERS	SHIMANO ALFINE 11

BRUSHED ALUMINUM, GLOSS (RAW)

HANDLEBAR/STEM	CANNONDALE TREKKING / UP C3 ADJUSTABLE
BRAKES	MAGURA MT2
SIZES	MEN'S: 48, 52, 56, 60 / WOMEN'S 48, 53, 55



TESORO 1/MIXTE

FRAME	TESORO SI, HEADSHOK, OPTIMIZED 6061 ALLOY, SAVE
FORK	HEADSHOK FATTY DL50, 50MM W/LOCKOUT, OPI
TIRES	SCHWALBE MARATHON SUPREME, 700X35C

JET BLACK, GLOSS (BLK)

CRANKS	FSA COMET 46/36/28
DERAILLEURS R/F	SHIMANO XT / SLX
SHIFTERS	SHIMANO SLX

JET BLACK, GLOSS (BLK) MIXTE

HANDLEBAR /STEM	CANNONDALE TREKKING / UP C3 ADJUSTABLE
BRAKES	MAGURA HS11
SIZES	MEN'S: 48, 52, 56, 60 / WOMEN'S 48, 53, 55



TESORO 2/MIXTE

FRAME	TESORO SI, OPTIMIZED 6061 ALLOY, SAVE
FORK	CANNONDALE SI CARBON BLADES
TIRES	SCHWALBE MARATHON SUPREME, 700X35C

CHARCOAL GRAY (GRY)

CRANKS	SHIMANO DEORE
DERAILLEURS R/F	SHIMANO SLX / SLX
SHIFTERS	SHIMANO DEORE

CHARCOAL GRAY (GRY) MIXTE

HANDLEBAR /STEM	CANNONDALE TREKKING / UP C3 ADJUSTABLE
BRAKES	AVID SINGLE DIGIT 5
SIZES	MEN'S: 48, 52, 56, 60 / WOMEN'S 48, 53, 55



TESORO 3/MIXTE

FRAME	TESORO SI, OPTIMIZED 6061 ALLOY, SAVE
FORK	CANNONDALE FATTY RIGID ALLOY
TIRES	SCHWALBE MARATHON SUPREME, 700X35C

FINE SILVER, GLOSS (SLV)	
CRANKS	SHIMANO ALIVIO
DERAILLEURS R/F	SHIMANO ALIVIO / ACERA
SHIFTERS	SHIMANO ACERA

FINE SILVER, GLOSS (SLV) MIXTE	
HANDLEBAR/STEM	CANNONDALE TREKKING / UP C3 ADJUSTABLE
BRAKES	AVID SINGLE DIGIT 5
SIZES	MEN'S: 48, 52, 56, 60 / WOMEN'S 48, 53, 55





WOMEN'S

I prodotti Cannondale per la donna sono creati per le donne, dalle donne, tutti guidati dalla filosofia per cui tutte le biciclette devono essere una miscela perfetta di adattabilità, caratteristiche tecniche e stile.



> OVERMOUNTAIN

SCARLET

2 bici in una, versatilità all-mountain per rider che pedalano duro.

> CROSS COUNTRY

LEXI

Bici a doppia sospensione agili e leggere per riding veloce su trail e avventure.

> TRAIL HARDTAIL

TRAIL SL 29'ER WOMEN'S
TRAIL SL WOMEN'S
TRAIL WOMEN'S

Mountain bike ad alte prestazioni per un trail riding a 360 gradi e divertimento off-road.





CALZATA: Ogni bici, sia che sia pensata per una racer avanzata oppure per una principiante, dovrebbe essere costruita per quella donna in particolare. Dalla geometria alla gamma dimensionale, il nostro impegno è volto a fornire il migliore adattamento alle donne di qualsiasi statura.

CARATTERISTICHE TECNICHE: Dai manubri più piccoli alle tarature idrauliche specifiche per ogni taglia, il nostro obiettivo è quello di

rendere queste bici utilizzabili così come sono al momento dell'acquisto. Meno interventi di regolazione e sostituzione significa poter uscire a pedalare quanto prima.

STILE: Il nostro team di designer per i prodotti da donna cercano l'ispirazione su più fronti: dai colori della moda ai nostri stessi atleti. Il risultato? Un aspetto grafico che ti invita ad esplorare la vita su due ruote.



> ELITE ROAD

SUPERSIX EVO WOMEN'S
SUPERSIX WOMEN'S
CAAD10 WOMEN'S

Bici da strada ultra-leggere ad alte prestazioni per atlete e donne che pedalano come atlete.

> PERFORMANCE ROAD

SYNAPSE CARBON WOMEN'S
SYNAPSE ALLOY WOMEN'S

Bici da strada ad alte prestazioni orientate al comfort studiate per incoraggiare a passare tempo in sella.

> TRIATHLON/TIME TRIAL

SLICE WOMEN'S

Bici aero leggere e confortevoli per correre contro il tempo.



SCARLET

> GUARDATE RAGAZZI... LA JEKYLL HA UNA SORELLA.

Con la sua doppia escursione OverMountain, capacità di due bici in una la Scarlet è la bike perfetta per la tipa che picchia duro, con la voglia di salire rapidamente e scendere ancora più rapidamente.



> DOPPIO AMMORTIZZATORE DYAD RT2

Due ammortizzatori in uno. ELEVATE - un ammortizzatore cross-country a corsa corta e FLOW - un ammortizzatore DH a corsa lunga, entrambi disponibili muovendo una semplice levetta.



> DOPPIA PERSONALITÀ

Cambia le modalità del DYAD e cambierà anche la geometria della bici. Più ripida e agile in modalità Elevate, più bassa e stabile in modalità Flow, in questo modo si mantiene sempre la migliore manovrabilità per il terreno.



> GEOMETRIA DA DONNA

Concepita per le donne. Taglie più piccole, tubi orizzontali più corti e uno standover maggiore rispetto alla Jekyll.



SCARLET 1

FRAME	SCARLET, 150/90MM, SMARTFORMED ALLOY
SUSPENSION, R/F	FOX 32 FLOAT CTD 150MM, 15QR / FOX DYAD RT2 150/90MM
WHEELS	WTB ST123 W/ FORMULA HUBS

CRANKS	SCHWALBE HANS DAMPE, 2.35" TUBELESS READY
DERAILLEURS, R/F	SRAM S1000, BB30, 36/22 W/GUARD
SHIFTERS	SHIMANO XT SHADOW + / SRAM X7

JET BLACK, MATTE (BBQ)

BRAKES	SHIMANO SLX
TIRES	MAGURA MT2 W/BAT HYDRAULIC DISC, 180/180MM
SIZES	P, S, M

LEXI

> SEMPLICEMENTE GIUSTA.

Con la sua geometria specifica per donna e un raffinato design monocross, la Lexi è una compagna di viaggio a tutto tondo leggera, agile e divertente che offre una performance su trail a tutta birra, che sia in gara o pedalando con le amiche.



LEXI 2

FRAME	LEXI, 120MM, SMARTFORMED ALLOY
SUSPENSION F/R	ROCKSHOX RECON GOLD TK, 120MM / ROCKSHOX MONARCH RL 120MM
WHEELS	MADDUX DC3.0 W/ FORMULA HUBS

TIRES	SCHWALBE RACING RALPH PERFORMANCE, 2.1"
CRANKS	SRAM S1000, BB30, 38/24
DERAILLEUR R/F	SRAM X9 / X7

MAGNESIUM WHITE, GLOSS (WHT)

SHIFTERS	SRAM X7
BRAKES	AVID ELIXIR 3, 180/160MM
SIZES	P,S,M

> SOSPENSIONE SPECIFICA PER TAGLIA

Attacchi ammortizzatore e sospensione specifici per la taglia significa che i rapporti di leva e le prestazioni degli ammortizzatori sono coerenti e precisi per tutte le taglie.

> ALLUMINIO SMARTFORMED

Un insieme di idroformatura, formatura meccanica, spessore variabile, saldature lisce a doppio passaggio e trattamento termico: SmartForming è la struttura in alluminio più avanzata al mondo, per telai più leggeri e più forti.

> TUBO STERZO SI DA 1,5"

Il tubo dello sterzo oversize agisce insieme alle forcelle del canotto sterzo da 1,5" per fornire un treno anteriore forte e super preciso nella sterzata.





TRAIL SL 29 WOMEN'S 2

FRAME	TRAIL SL 29"ER, OPTIMIZED 6061 ALLOY, SAVE
SUSPENSION F/R	ROCKSHOX RECON SILVER TK 29 80MM, W/ LOCKOUT
WHEELS	MADDUX DC3.0 29"ER W/ FORMULA HUBS

TIRES	KENDA SMALL BLOCK 8, 2.1"
CRANKS	SHIMANO FC-M391-8, 44/32/22
DERAILLEUR R/F	SHIMANO DEORE / ALIVIO

MAGNESIUM WHITE, GLOSS (WHT)	
SHIFTERS	SHIMANO ALIVIO
BRAKES	CANNONDALE HELIX 6 HYDRAULIC DISC, 180/160MM
SIZES	S,M,T



TRAIL SL 3 WOMEN'S

FRAME	TRAIL SL, WOMEN'S, OPTIMIZED 6061 ALLOY, SAVE
SUSPENSION F/R	ROCKSHOX XC 30 TK, COIL, 100MM W/ LOCKOUT
WHEELS	MADDUX DC3.0 W/ C4 HUBS

TIRES	SCHWALBE RAPID ROB 2.1"
CRANKS	SHIMANO FC-M430-8, 44/32/22
DERAILLEUR R/F	SHIMANO DEORE / ACERA

MAGNESIUM WHITE, GLOSS (WHT)	
SHIFTERS	SHIMANO ALIVIO
BRAKES	SHIMANO BR-M446, 160/160MM
SIZES	P,S,M,T



TRAIL SL 4 WOMEN'S

FRAME	TRAIL SL, WOMEN'S, OPTIMIZED 6061 ALLOY, SAVE
SUSPENSION F/R	SR SUNTOUR XCR-LO, COIL, 100MM W/ LOCKOUT
WHEELS	MADDUX DC3.0 W/ C4 HUBS

TIRES	SCHWALBE RAPID ROB 2.1"
CRANKS	SHIMANO FC-M391-8, 44/32/22
DERAILLEUR R/F	SHIMANO ALIVIO / ALTUS

NIAGARA BLUE, GLOSS (BLU)	
SHIFTERS	SHIMANO ACERA
BRAKES	CANNONDALE HELIX 6 HYDRAULIC DISC, 160/160MM
SIZES	P,S,M,T



TRAIL SL 5 WOMEN'S

FRAME	TRAIL SL, WOMEN'S, OPTIMIZED 6061 ALLOY, SAVE
SUSPENSION F/R	SR SUNTOUR XCM-HLO, COIL, 100MM W/ LOCKOUT
WHEELS	MADDUX DC3.0 W/ C4 HUBS

TIRES	SCHWALBE RAPID ROB 2.1"
CRANKS	SHIMANO FC-M311-8, 44/32/22
DERAILLEUR R/F	SHIMANO ACERA / ALTUS

JET BLACK, GLOSS (BLK)	
SHIFTERS	SHIMANO ALTUS
BRAKES	CANNONDALE HELIX 6 HYDRAULIC DISC, 160/160MM
SIZES	P,S,M,T

SUPERSIX EVO WOMEN'S

> LA MACCHINA DA STRADA DA DONNA PIÙ AVANZATA MAI CREATA.

La “migliore bici al mondo”, ridisegnata specificamente per la donna. Con la sua miscela quasi perfetta di peso estremamente leggero, vivace efficienza, calzata ideale e morbido comfort di guida, la EVO è la macchina definitiva per le racer d'élite (o quelle che vogliono guidare come se lo fossero).

DUE OPZIONI DI TELAIO IN CARBONIO BALLISTEC

> EVO HI-MOD: Il più leggero telaio da corsa da donna al mondo. La struttura in carbonio BallisTec ad alto modulo garantisce leggerezza e rigidità estreme.

> EVO CARBON: La stessa struttura ma con una percentuale superiore di fibra a modulo intermedio. Con un peso inferiore ai 900 grammi, è ancora uno dei telai da donna più leggeri al mondo.

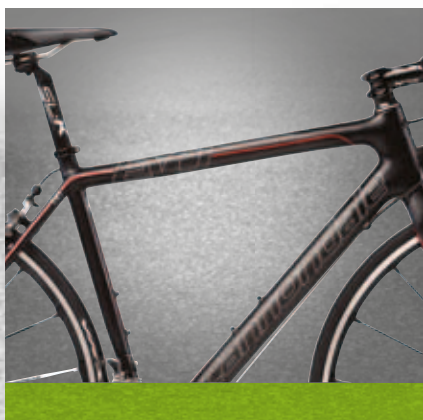

> GEOMETRIA RACING ELITE

Nuova geometria elite women's basata su altezza e lunghezza offre un margine omogeneo tra ciascuna delle 5 taglie disponibili (48-56), assicurando che ciascuna di loro offra la calzata e la manovrabilità ideali.



> SISTEMA DI MICRO-SOSPENSIONE SPEED SAVE

Sottili zone flettenti integrate nei foderi bassi e alti consentono alla ruota di seguire il tracciato del terreno, migliorando la velocità, la manovrabilità e il comfort. Adattata per l'uso con la forcella SPEED SAVE.



> FORCELLA SPEED SAVE

Una stratificazione direzionale del carbonio BallisTec e i forcellini offset conferiscono alla forcella la capacità di assorbire gli urti, pur mantenendo una manovrabilità affilata come una lama. Disponibile in 2 rake per eliminare la l'interferenza della punta del piede nelle taglie più piccole.

WOMEN'S
 OVERMOUNTAIN
 CROSS COUNTRY
 TRAIL HARDTAILS
 ELITE ROAD
 PERFORMANCE ROAD
 TRIATHLON / TIME TRIAL



SUPERSIX EVO D12 ULTEGRA WOMEN'S

FRAME	SUPERSIX EVO WOMEN'S, BALLISTEC CARBON, D12 SPECIFIC, SPEED SAVE
FORK	SUPERSIX EVO, SPEED SAVE, BALLISTEC CARBON
WHEELS	SHIMANO ULTEGRA 6700 TUBELESS

TIRES	SCHWALBE ULTREMO TUBELESS 700X23C
CRANKS	CANNONDALE HOLLOWGRAM SI, FSA CHAINRINGS, 50/34
DERAILLEURS	SHIMANO ULTEGRA D12 6770

EXPOSED UNI-DIRECTIONAL CARBON W/ HOLLYWOOD SILVER, GLOSS (BLK)

SHIFTERS	SHIMANO ULTEGRA D12 6770
BRAKES	SHIMANO ULTEGRA 6700
SIZES	44, 48, 51, 54, 56



SUPERSIX 5 105 WOMEN'S

FRAME SUPERSIX WOMEN'S, FULL CARBON

FORK SUPERSIX, FULL CARBON, ALLOY DROPOUTS

WHEELS SHIMANO RS-10

TIRES SCHWALBE LUGANO, 700X23C, FOLDING

CRANKS FSA GOSSAMER PRO, BB30, 50/34

DERAILLEURS SHIMANO 105 5700

EXPOSED UNI-DIRECTIONAL CARBON W/ LIME FROST, GLOSS (BLK)

SHIFTERS SHIMANO 105 5700

BRAKES SHIMANO 105 5700

SIZES 44, 48, 51, 54

> REVE TOUR.

"21 tappe, 3479km, 25 passi di montagna;
Reve tour."

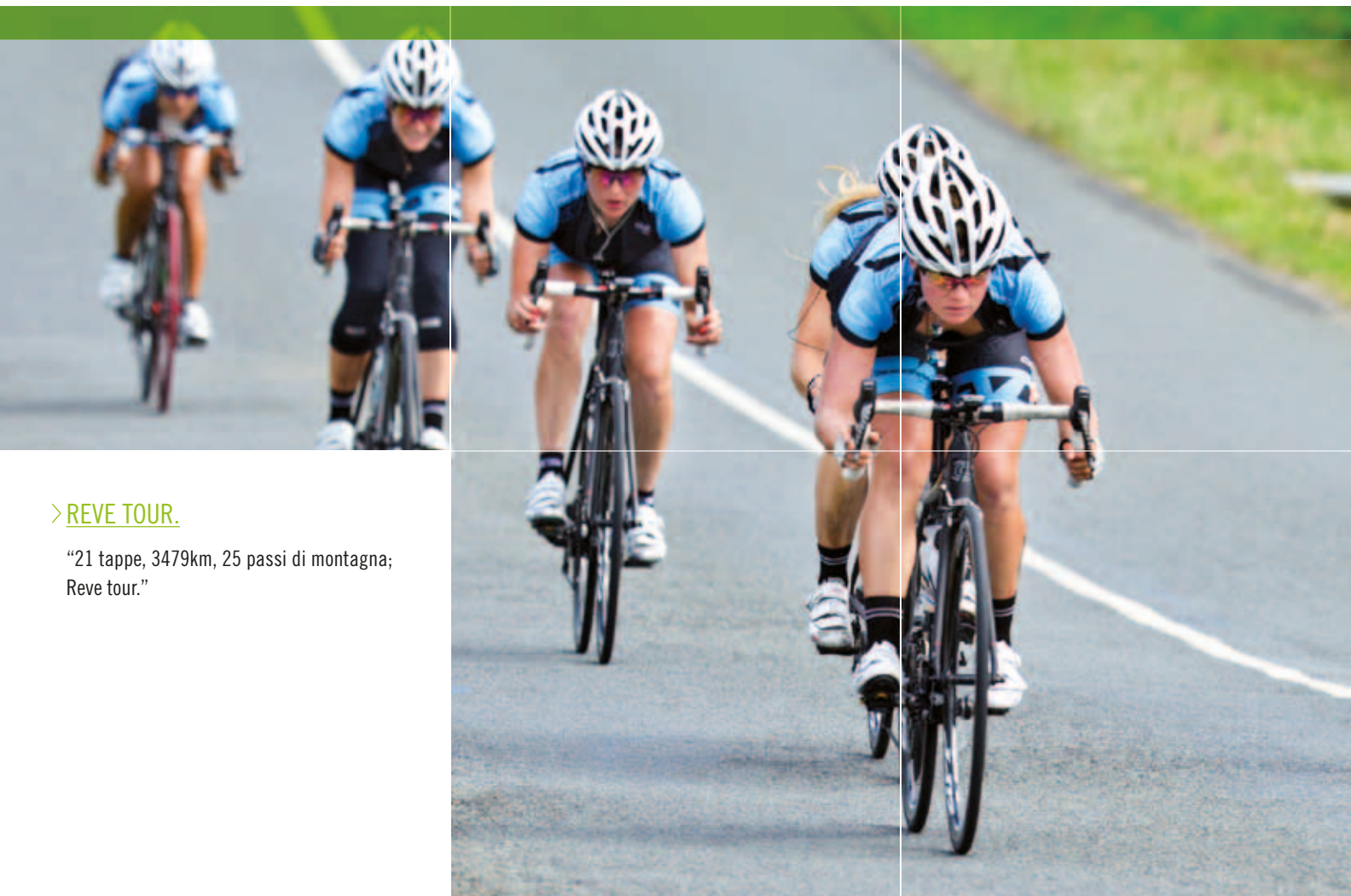



CAAD10 3 ULTEGRA WOMEN'S

FRAME	CAAD10 WOMEN'S, SMARTFORMED 6069 ALLOY, SPEED SAVE
FORK	CAAD10, SPEED SAVE FULL CARBON
WHEELS	MAVIC AKSIUM WTS

TIRES	MAVIC AKSIUM, 700X23C, FOLDING
CRANKS	FSA SL-K LIGHT CARBON BB30, 50/34
DERAILLEURS	SHIMANO ULTEGRA 6700

MAGNESIUM WHITE W/ NIAGRA BLUE, GLOSS (WHT)

SHIFTERS	SHIMANO ULTEGRA 6700
BRAKES	SHIMANO ULTEGRA 6700
SIZES	44, 48, 51, 54



CAAD10 5 105 WOMEN'S

FRAME	CAAD10 WOMEN'S, SMARTFORMED 6069 ALLOY, SPEED SAVE
FORK	CAAD10, SPEED SAVE FULL CARBON
WHEELS	SHIMANO RS-10

TIRES	SCHWALBE LUGANO, 700X23C, FOLDING
CRANKS	FSA GOSSAMER PRO, BB30, 50/34
DERAILLEURS	SHIMANO 105 5700

MAGNESIUM WHITE W/ LIME FROST, GLOSS (WHT)

SHIFTERS	SHIMANO 105 5700
BRAKES	SHIMANO 105 5700
SIZES	44, 48, 51, 54

SYNAPSE CARBON WOMEN'S

➤ MORBIDA COME LA SETA. STRAORDINARIAMENTE VELOCE.

La Synapse è una potente miscela di velocità a peso leggero e comfort per tutta la giornata. Disponibile come Synapse Carbon ultra-leggera o versatile Synapse Alloy, è la scelta perfetta per le gran fondo, il triathlon e tutto ciò che ci sta in mezzo.



SYNAPSE CARBON ULTEGRA WOMEN'S

FRAME SYNAPSE WOMEN'S, FULL CARBON, SAVE PLUS

FORK SYNAPSE, FULL CARBON, SAVE PLUS

WHEELS MAVIC AKSIUM WTS

TIRES MAVIC AKSION, 700X25C, FOLDING

CRANKS FSA SL-K LIGHT CARBON BB30, 52/39/30

DERAILLEURS SHIMANO ULTEGRA 6700

MAGNESIUM WHITE W/ TANGERINE DREAM, GLOSS (WHT)

SHIFTERS SHIMANO ULTEGRA 6700

BRAKES SHIMANO ULTEGRA 6700

SIZES 44, 48, 51, 54

➤ GEOMETRIA PERFORMANTE PER LA DONNA

La nostra geometria a testa alta Women's Performance offre una posizione di guida più eretta e confortevole ed una manovrabilità vivace ma stabile, grazie a un tubo verticale più alto, un tubo orizzontale dalla curva morbida, angolo dello sterzo leggermente rilassato ed un passo leggermente più lungo rispetto alla nostra geometria elite.

➤ SAVE PLUS SISTEMA DI MICRO-SOSPENSIONE

Il triangolo posteriore SAVE PLUS è progettato per riuscire a flettersi leggermente in modo da assorbire urti e vibrazioni della strada, pur rimanendo rigido per l'erogazione della potenza e una manovrabilità sicura.

➤ FORCELLA IN CARBONIO INTEGRALE SAVE PLUS

La forcella SAVE PLUS è messa a punto per lavorare come sistema con i foderi posteriori SAVE PLUS, assorbendo gli urti e lasciando al rider il controllo in modo confortevole.



SYNAPSE CARBON 5 105 WOMEN'S

FRAME	SYNAPSE WOMEN'S, FULL CARBON, SAVE PLUS
FORK	SYNAPSE, FULL CARBON, SAVE PLUS
WHEELS	SHIMANO RS-10

TIRES	SCHWALBE LUGANO, 700X25C, FOLDING
CRANKS	FSA GOSSAMER PRO, BB30, 50/39/30
DERAILLEURS	SHIMANO 105 5700

MAGNESIUM WHITE W/ HOLLYWOOD SILVER, GLOSS (WHT)	
SHIFTERS	SHIMANO 105 5700
BRAKES	SHIMANO 105 5700
SIZES	44, 48, 51, 54



SYNAPSE 6 TIAGRA WOMEN'S

FRAME	WOMEN'S SYNAPSE ALLOY, OPTIMIZED 6061 ALLOY, SAVE PLUS, BB30
FORK	SYNAPSE SAVE, CARBON BLADES
WHEELS	MADDUX R3.0, 32 HOLE W/ C4 HUBS

TIRES	SCHWALBE LUGANO, 700X25C
CRANKS	FSA OMEGA, BB30, 50/39/30
DERAILLEURS	SHIMANO TIAGRA 4600

MAGNESIUM WHITE W/ ROSY TOMORROW, GLOSS (WHT)	
SHIFTERS	SHIMANO SORA
BRAKES	CANNONDALE C4, DUAL PIVOT, LONG REACH
SIZES	44, 48, 51, 54, 56

SLICE WOMEN'S

> VELOCE. FEMMINILE.

Più volte vincitrice della gara di Kona. Detentrica del record mondiale. La Slice si presenta da sola. Questa struttura super leggera a prova di gara abbina un'elevata aerodinamicità, una calzata perfetta e una morbidezza confortevole, tutto in un pacchetto semplice da regolare, da utilizzare e da mantenere.



SLICE 3 ULTEGRA WOMEN'S

FRAME SLICE WOMEN'S, FULL CARBON, AERO SAVE

FORK SLICE AERO, FULL CARBON

WHEELS VISION TEAM 30

TIRES SCHWALBE LUGANO, 700X23C, FOLDING (VITTORIA RUBINO 650X23C, FOLDING)

CRANKS FSA SL-K LIGHT CARBON BB30, 50/34

DERAILLEURS SHIMANO ULTEGRA 6700

CHARCOAL GRAY W/ PORCELAIN BLUE, MATTE (GRY)

SHIFTERS SHIMANO ULTEGRA 6700

BRAKES SHIMANO ULTEGRA 6700

SIZES 47, 51, 54

> SISTEMA DI MICRO-SOSPENSIONE AERO SAVE

Un'elegante combinazione di formatura direzionale dei tubi e di sofisticata stratificazione del carbonio consente ai foderi bassi posteriori e a quelli alti di flettersi insieme verticalmente, in modo che sia la bici ad assorbire gli urti, e non il ciclista. Per essere aerodinamici più a lungo e scendere più velocemente dalla bici.

> RUOTE DA 650C

Le ruote da 650c sulla nostra taglia da 47cm significa che il tubo dello sterzo è più basso rispetto alle bici con ruote da 700c, in questo modo anche le rider più basse possono trovare il perfetto adattamento aero. Inoltre per queste la sovrapposizione della punta del piede è inferiore e possono ottenere una migliore aerodinamicità rispetto alle bici con ruote più grandi.

> STRUTTURA DI FACILE MANUTENZIONE

Freni standard da strada, normale struttura attacco manubrio/canotto sterzo, passaggio diretto dei cavi e forcellini posteriori verticali: tutto contribuisce a un vantaggio puramente aero del design di questa superbike, ma con facilità di regolazione, uso e manutenzione.



> **BETH WELSH.**

“È così leggera e morbida. La Slice mi aiuta ad andare più forte.”

KIDS

> LA TECNOLOGIA E IL DESIGN DEI TELAI CANNONDALE È ORA DISPONIBILE PER I BAMBINI.

Offriamo bici da 16" e 24" belle, sicure e confortevoli con una ineguagliabile identità Cannondale. I nostri modelli dispongono di passaggio cavi interno, stand-over e top-tubes adeguati e leggere forcelle in alluminio. Con dettagli come leve dei freni facili da raggiungere, componentistica leggera e parti marchiate Cannondale come manopole e selle che assicurano al tuo bambino la miglior pedalata di sempre. Nelle pagine seguenti troverete una selezione della nostra linea. Per maggiori informazioni non esitate a visitare il nostro sito internet.



RACE, BOY'S 24" 21 SPEED

FRAME CANNONDALE SHAPED AND OPTIMIZED 6061 ALLOY

FORK RST FIRST24 AIR W/ALLOY STEERER

TIRES CANNONDALE 24X2.0", FOLDING

CRANKS SUNTOUR ALLOY 152MM CRANK, 24/34/42T

DERAILLEURS R/F SHIMANO, TX-35, 7 SPEED, MEGARANGE / SHIMANO, TX-50, 31.8 BAND

SHIFTERS SHIMANO, RS-36, REVO TWIST

JET BLACK W/BERSERKER GREEN, GLOSS

HANDLEBAR/STEM ALLOY, 580MM WIDE, 25.4MM AVID ELIXIR 9 CARBON / CANNONDALE CUSTOM

BRAKES V-BRAKE, ALLOY LINEAR PULL

SIZES MEDIUM, LARGE

> SALDATURE LISCE

Il marchio di fabbrica Cannondale delle saldature lisce a doppio passaggio elimina i punti di stress e i punti deboli che si possono trovare sui telai saldati in modo tradizionale, permettendoci di costruire telai più leggeri e più resistenti.

> SERIE STERZO INTEGRATA

La serie sterzo integrata dona alle nostre bici da bambino un minor peso e la finitura che ci si aspetta su biciclette di alto livello.

> CASCHI

Per garantire la sicurezza, assicurati di indossare un casco Cannondale. La tecnologia di stampo In Fusion e il Easy Fit System assicurano durata, leggerezza e confort.



RACE, GIRL'S 24" 21 SPEED

FRAME	CANNONDALE SHAPED AND OPTIMIZED 6061 ALLOY
FORK	RST FIRST24 AIR W/ALLOY STEERER
TIRES	CANNONDALE 24X2.0", FOLDING

CRANKS	SUNTOUR ALLOY 152MM CRANK, 24/34/42T STEEL
DERAILLEURS R/F	SHIMANO, TX-35, 7 SPEED, MEGARANGE / SHIMANO, TX-50, 31.8 BAND
SHIFTERS	SHIMANO ACERA

CHARCOAL GRAY W/ CORAL PINK, GLOSS

HANDLEBAR/STEM	CANNONDALE C4
BRAKES	SHIMANO M395 HYDRAULIC DISC
SIZES	S, M, L, X



> [QUICK KIDS BOYS](#)



TRAIL, BOY'S / GIRLS 20" 6 SPEED

FRAME	CANNONDALE SHAPED AND OPTIMIZED 6061 ALLOY
FORK	SUNTOUR XCT-JR 20, 1-1/8" STEERER
TIRES	CANNONDALE 20X2.0", WIRE BEAD

BRUSHED ALUMINUM W/ BERSERKER GREEN, GLOSS	
CRANKS	ALLOY 152MM CRANK, 36T STEEL CHAINRING
DERAILLEURS R/F	SHIMANO, TX-35, 6-7 SPEED, MEGARANGE / N/A
SHIFTERS	SHIMANO, RS-36, REVO TWIST



WHITE W/ULTRA BLUE, GLOSS (WHT)	
HANDLEBAR/STEM	ALLOY, 560MM WIDE, 25.4MM / CANNONDALE CUSTOM
BRAKES	V-BRAKE, ALLOY LINEAR PULL
SIZES	ONE SIZE



TRAIL, GIRLS / BOYS 20" 1 SPEED

FRAME	CANNONDALE SHAPED AND OPTIMIZED 6061 ALLOY
FORK	6061 ALLOY RIGID, 1-1/8" STEERER
TIRES	CANNONDALE 20X2.0", WIRE BEAD

SUNRISE W/ HOT MAGENTA, GLOSS	
CRANKS	36T STEEL RING
DERAILLEURS R/F	N/A / N/A
SHIFTERS	N/A



JET BLACK W/REFLECTIVE DECALS, MATTE (BBQ)	
HANDLEBAR/STEM	ALLOY, 560MM WIDE, 25.4MM / CANNONDALE CUSTOM
BRAKES	V-BRAKE FRONT, COASTER REAR
SIZES	ONE SIZE



> QUICK KIDS GIRLS



TRAIL, BOYS / GIRLS 16" 1 SPEED

FRAME	CANNONDALE SHAPED AND OPTIMIZED 6061 ALLOY
FORK	6061 ALLOY RIGID, 1-1/8" STEERER
TIRES	CANNONDALE 16X2.0", WIRE BEAD

FRAME	JET BLACK, MATTE (BBQ)
CRANKS	28T STEEL RING
DERAILLEURS R/F	N/A / N/A
SHIFTERS	N/A

FRAME	CHARCOAL GRAY W/ PINK, GLOSS (PNK)
HANDLEBAR/STEM	ALLOY RISER, 80MM RISE, 520MM WIDE, 22.2MM / ALLOY AHEAD, 37MM
BRAKES	N/A / N/A
SIZES	ONE SIZE

HELMETS

PROTEZIONE. PERFETTA. Novità per il 2013

CYPHER

ANDRAI COSÌ VELOCE CHE LA GENTE PENSERÀ CHE LO HAI RUBATO.

La tecnologia del guscio con Protezione massima utilizza una schiuma EPS a doppia densità per ridurre il peso e mantenere al contempo i più elevati standard di sicurezza industriali.

La gabbia interna in policarbonato rinforza le prese d'aria per renderlo il migliore in quanto a sicurezza e ventilazione.

La tecnologia del guscio in policarbonato a catalizzazione multipla lega il guscio esterno alla schiuma EPS per creare un design unico integrato.

La vestibilità con micro-regolazione integrata con cuscinetto occipitale EVA Ergo-Fit offre un comfort senza precedenti e una vestibilità personalizzabile.

23 prese di aerazione in grado di mantenere un flusso d'aria all'interno del casco e mantenere la temperatura costante, mentre le imbottiture sigillate a caldo assorbono il sudore.

Una comoda rete morbida al tatto con divisori bloccanti assicura una regolazione sicura e comfort per tutto il giorno.



BLK/GRN

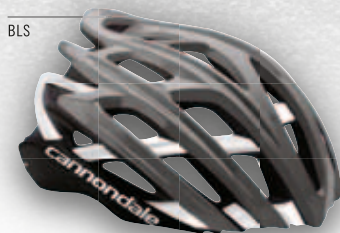

BLS

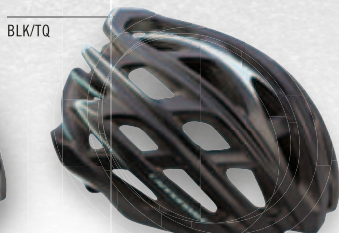

BLK/TQ



GRN



WTS



CFR

TERAMO

La tecnologia del guscio con Protezione massima utilizza una schiuma EPS a doppia densità per ridurre il peso e mantenere al contempo i più elevati standard di sicurezza industriali.

La gabbia interna in policarbonato rinforza le prese d'aria per renderlo il migliore in quanto a sicurezza e ventilazione.

La tecnologia del guscio in policarbonato a catalizzazione multipla lega il guscio esterno alla schiuma EPS per creare un design unico integrato.

La vestibilità con micro-regolazione integrata con cuscinetto occipitale EVA Ergo-Fit offre un comfort senza precedenti e una vestibilità personalizzabile.

23 prese di aerazione in grado di mantenere un flusso d'aria all'interno del casco e mantenere la temperatura costante, mentre le imbottiture sigillate a caldo assorbono il sudore.

Una comoda rete morbida al tatto con divisori bloccanti assicura una regolazione sicura e comfort per tutto il giorno.



WHT/BL



SLV



CFR

RYKER

La vestibilità con micro-regolazione integra con cuscinetto occipitale EVA Ergo-Fit offre un comfort senza precedenti e una vestibilità personalizzabile

19 prese di aerazione distribuite all'interno del casco mantengono fresco il ciclista su qualsiasi terreno

Le imbottiture saldate a caldo mantengono il sudore sotto controllo

La tecnologia del guscio in policarbonato a catalizzazione singola lega il guscio esterno alla schiuma EPS per creare un design unico integrato

Una comoda rete morbida al tatto con divisori bloccanti assicura una regolazione sicura e comfort per tutto il giorno

Visiera rimovibile



BLK/SLV

MOUNTAIN SPECIFICATIONS

CLAYMORE 1	
PRODUCT CODE	C13VA1
FRAME	CLAYMORE, 180/110MM, SMARTFORMED ALLOY, BB30, ISCG03, DIABLO 1.5 SI HEAD TUBE
FORK	FOX 36 TALAS R, PERFORMANCE, 180MM, 20QR THRU AXLE, 1.5"
REAR SHOCK	FOX DYAD RT2 DUAL SHOCK, 180/110MM, W/REMOTE LEVER
RIMS	SUN RINGLE CHARGER PRO, TUBELESS READY
HUBS	SUN RINGLE CHARGER PRO, 20MM FRONT, 142X12MM REAR
SPOKES	SUN RINGLE CHARGER PRO
TIRES	SCHWALBE HANS DAMPF SNAKESKIN TRAILSTAR, 2.35" TUBELESS READY
PEDALS	N/A
CRANKS	SRAM S1400, BB30, 36/22
BOTTOM BRACKET	SRAM BB30
CHAIN	KMC X10
REAR COGS	SRAM PG-1070, 11-36, 10-SPEED
FRONT DERAILLEUR	SRAM X7, DIRECT MOUNT
REAR DERAILLEUR	SHIMANO XT SHADOW+
SHIFTERS	SHIMANO XT, W/1-SPEC
HANDLEBAR	FSA GRAVITY LITE ALLOY, 740X15MM RISE
GRIPS	CANNONDALE DUAL LOCKING GRIPS
STEM	FSA GRAVITY LITE, 1.5", 31.8
HEADSET	TANGE SEIKI 1.5", SI ANGULAR CONTACT
BRAKES	SHIMANO XT TRAIL, 203/180MM
BRAKE LEVERS	SHIMANO XT TRAIL
SADDLE	PROLOGO SCRATCH X18
SEATPOST	ROCKSHOX REVERB, 31.6X385MM HEIGHT ADJUSTABLE
SIZES	S, M, L
COLOR (CODE)	MAGNESIUM WHITE, GLOSS (WHT)
EXTRAS	HIGH PRESSURE SHOCK PUMP, SYNTACE X-12MM REAR AXLE, MRP 2X GUIDE

JEKYLL CARBON 2	
PRODUCT CODE	C13VN2
FRAME	JEKYLL, 150/90MM, BALLISTEC HI-MOD CARBON, BB30, ISCG03, 1.5SI HEADTUBE
FORK	FOX 34 TALAS CTD, O/C, EVOLUTION, 160MM, 15QR THRU AXLE, 1.5"
REAR SHOCK	FOX DYAD RT2 DUAL SHOCK, 150/90MM, W/REMOTE LEVER
RIMS	MAVIC CROSSTRAIL, TUBELESS READY
HUBS	MAVIC CROSSTRAIL, 15MM FRONT, 142X12MM REAR
SPOKES	MAVIC CROSSTRAIL
TIRES	SCHWALBE HANS DAMPF SNAKESKIN TRAILSTAR, 2.35" TUBELESS READY
PEDALS	N/A
CRANKS	SRAM S2210, BB30, 36/22
BOTTOM BRACKET	SRAM BB30
CHAIN	KMC X10SL
REAR COGS	SRAM PG-1070, 11-36, 10-SPEED
FRONT DERAILLEUR	SRAM X7, DIRECT MOUNT
REAR DERAILLEUR	SRAM X9 TYPE2 RBC
SHIFTERS	SRAM X9
HANDLEBAR	FSA GRAVITY LITE ALLOY, 740X15MM RISE
GRIPS	CANNONDALE DUAL LOCKING GRIPS
STEM	CANNONDALE C1, 1.5", 31.8
HEADSET	TANGE SEIKI 1.5", INTEGRATED
BRAKES	MAGURA MT4, 180/160MM
BRAKE LEVERS	MAGURA MT4
SADDLE	WTB VOLT NICO SL
SEATPOST	XFUSION HILO W/REMOTE
SIZES	S, M, L, XL
COLOR 1 (CODE)	JET BLACK, W/ NEARLY BLACK AND I LOVE GOLD ACCENTS, MATTE (BBQ)
COLOR 2 (CODE)	ULTRA BLUE W/ MAGNESIUM WHITE AND 40 ORANGE ACCENTS, GLOSS (BLU)
EXTRAS	HIGH PRESSURE SHOCK PUMP, SYNTACE X-12MM REAR AXLE, MRP 2X GUIDE

TRIGGER 29'ER 2	
PRODUCT CODE	C13VZ92
FRAME	TRIGGER 29'ER, 130/80MM, SMARTFORMED ALLOY, BB30, ISCG03, 1.5SI HEAD TUBE
FORK	FOX 34 FLOAT 29 FIT CTD, PERFORMANCE, 130MM, 15QR THRU AXLE, 1.5"
REAR SHOCK	FOX DYAD RT2 DUAL SHOCK, 130/80MM, W/REMOTE LEVER
RIMS	WTB FREQUENCY RACE I23 29'ER TCS, 32 HOLE, TUBELESS READY
HUBS	FORMULA, 32 HOLE, 15MM THRU AXLE FRONT, 142X12MM REAR
SPOKES	DT SWISS CHAMPION
TIRES	SCHWALBE HANS DAMPF SNAKESKIN, 29X2.35", FOLDING
PEDALS	N/A
CRANKS	SRAM S1000, BB30, 36/22 W/GUARD
BOTTOM BRACKET	SRAM BB30
CHAIN	KMC X10, 10-SPEED
REAR COGS	SRAM PG 1030, 11-36, 10-SPEED
FRONT DERAILLEUR	SRAM X7, DIRECT MOUNT
REAR DERAILLEUR	SRAM X9 TYPE2 RBC
SHIFTERS	SRAM X7, W/MAGURA SHIFTMIX
HANDLEBAR	CANNONDALE C2 RISER, 700X20MM, 2014 ALLOY
GRIPS	CANNONDALE D3 DUAL LOCK ON
STEM	CANNONDALE C3, 1.5", 31.8
HEADSET	TANGE SEIKI 1.5", INTEGRATED
BRAKES	MAGURA MT2 W/BAT, 180/160MM
BRAKE LEVERS	MAGURA MT2 W/BAT
SADDLE	WTB VOLT SATIN STEEL
SEATPOST	CANNONDALE C2, 31.6X350MM
SIZES	S, M, L, X
COLOR 1 (CODE)	JET BLACK, MATTE (BBQ)
COLOR 2 (CODE)	N/A
EXTRAS	HIGH PRESSURE SHOCK PUMP, SYNTACE X-12MM REAR AXLE

CLAYMORE 2	
PRODUCT CODE	C13VA2
FRAME	CLAYMORE, 180/110MM, SMARTFORMED ALLOY, BB30, ISCG03, DIABLO 1.5 SI HEAD TUBE
FORK	FOX 36 VAN R O/B, PERFORMANCE, 180MM, 20QR THRU AXLE, 1.5"
REAR SHOCK	FOX DYAD RT2 DUAL SHOCK, 180/110MM, W/REMOTE LEVER
RIMS	WTB ST I23 TCS, TUBELESS READY
HUBS	SUN RINGLE CHARGER PRO, 20MM THRU AXLE FRONT, 142X12MM REAR
SPOKES	DT SWISS CHAMPION
TIRES	WTB VIGILANTE TCS, 2.3, TUBELESS READY
PEDALS	N/A
CRANKS	TRUVATIVI HUSSEFELT, 36/24
BOTTOM BRACKET	TRUVATIVI HOWITZER
CHAIN	KMC X10
REAR COGS	SRAM PG-1030, 11-36, 10-SPEED
FRONT DERAILLEUR	SRAM X7, DIRECT MOUNT
REAR DERAILLEUR	SRAM X7
SHIFTERS	SRAM X7, W/MATCHMAKER
HANDLEBAR	CANNONDALE C3 RISER, 740X18MM, 2014 ALLOY
GRIPS	CANNONDALE DUAL LOCKING GRIPS
STEM	CANNONDALE C3, 1.5", 31.8
HEADSET	TANGE SEIKI 1.5", SI ANGULAR CONTACT
BRAKES	AVID ELIXIR 5, 200/180MM
BRAKE LEVERS	AVID ELIXIR 5
SADDLE	CANNONDALE STAGE 3 CROMO
SEATPOST	CANNONDALE C3, 31.6X350MM
SIZES	S, M, L
COLOR (CODE)	JET BLACK, GLOSS (BLK)
EXTRAS	HIGH PRESSURE SHOCK PUMP, SYNTACE X-12MM REAR AXLE, MRP 2X GUIDE

JEKYLL 3	
PRODUCT CODE	C13VN3
FRAME	JEKYLL, 150/90MM, SMARTFORMED ALLOY, BB30, ISCG03, 1.5SI HEAD TUBE
FORK	FOX 32 FLOAT CTD O/C, EVOLUTION, 150MM, 15QR THRU AXLE, 1.5"
REAR SHOCK	FOX DYAD RT2 DUAL SHOCK, 150/90MM, W/REMOTE LEVER
RIMS	SHIMANO MT68, TUBELESS READY
HUBS	SHIMANO MT68, 15MM FRONT, 142X12MM REAR
SPOKES	SHIMANO MT68
TIRES	WTB VIGILANTE 2.3 TCS FRONT, MOTO 2.3 TCS REAR, TUBELESS READY
PEDALS	N/A
CRANKS	SRAM S1400, BB30, 36/22
BOTTOM BRACKET	SRAM BB30
CHAIN	KMC X10
REAR COGS	SRAM PG-1030, 11-36, 10-SPEED
FRONT DERAILLEUR	SRAM X7, DIRECT MOUNT
REAR DERAILLEUR	SHIMANO XT SHADOW+
SHIFTERS	SHIMANO SLX
HANDLEBAR	CANNONDALE C3 RISER, 740X18MM, 2014 ALLOY
GRIPS	CANNONDALE DUAL LOCKING GRIPS
STEM	CANNONDALE C1, 1.5", 31.8
HEADSET	TANGE SEIKI 1.5", INTEGRATED
BRAKES	MAGURA MT2 W/BAT, 180/160MM
BRAKE LEVERS	MAGURA MT2 W/BAT
SADDLE	WTB VOLT SATIN STEEL
SEATPOST	CANNONDALE C2, 31.6X350MM
SIZES	S, M, L, XL
COLOR 1 (CODE)	JET BLACK, MATTE (BBQ)
COLOR 2 (CODE)	N/A
EXTRAS	HIGH PRESSURE SHOCK PUMP, SYNTACE X-12MM REAR AXLE

TRIGGER 29'ER 3	
PRODUCT CODE	C13VZ93
FRAME	TRIGGER 29'ER, 130/80MM, SMARTFORMED ALLOY, BB30, ISCG03, 1.5SI HEAD TUBE
FORK	ROCKSHOX REVELATION RL 29, 130MM, 15QR THRU AXLE, 1.5"
REAR SHOCK	XFUSION P1-RL 130MM, W/REMOTE LEVER
RIMS	WTB ST I23 29'ER TCS, 32 HOLE, TUBELESS READY
HUBS	FORMULA, 32 HOLE, 15MM THRU AXLE FRONT, 142X12MM REAR
SPOKES	DT SWISS CHAMPION
TIRES	WTB VIGILANTE TCS, 29X2.25"
PEDALS	N/A
CRANKS	SRAM S1000, BB30, 36/22 W/GUARD
BOTTOM BRACKET	SRAM BB30
CHAIN	KMC X10, 10-SPEED
REAR COGS	SRAM PG 1030, 11-36, 10-SPEED
FRONT DERAILLEUR	SRAM X7, DIRECT MOUNT
REAR DERAILLEUR	SHIMANO XT
SHIFTERS	SHIMANO SLX
HANDLEBAR	CANNONDALE C3 RISER, 700X20MM, 6061 ALLOY
GRIPS	CANNONDALE D3 DUAL LOCK ON
STEM	CANNONDALE C4, 1.5", 31.8
HEADSET	TANGE SEIKI 1.5", INTEGRATED
BRAKES	MAGURA MT2, 180/160MM
BRAKE LEVERS	MAGURA MT2
SADDLE	CANNONDALE STAGE 2
SEATPOST	CANNONDALE C2, 31.6X350MM
SIZES	S, M, L, X
COLOR 1 (CODE)	MAGNESIUM WHITE W/ JET BLACK AND ULTRA BLUE ACCENTS, GLOSS (BLU)
COLOR 2 (CODE)	N/A
EXTRAS	HIGH PRESSURE SHOCK PUMP, SYNTACE X-12MM REAR AXLE

JEKYLL MX	
PRODUCT CODE	C13VNX
FRAME	JEKYLL, 150/90MM, SMARTFORMED ALLOY, BB30, ISCG03, 1.5SI HEAD TUBE
FORK	FOX 36 FLOAT R, O/C, PERFORMANCE, 160MM, 20QR THRU AXLE, 1.5"
REAR SHOCK	FOX DYAD RT2 DUAL SHOCK, 150/90MM, W/REMOTE LEVER
RIMS	WTB STRYKER TCS I23, TUBELESS READY
HUBS	WTB STRYKER TCS I23, 20MM FRONT, 142X12MM REAR
SPOKES	WTB STRYKER TCS I23
TIRES	WTB VIGILANTE 2.3 TCS FRONT, MOTO 2.3 TCS REAR, TUBELESS READY
PEDALS	N/A
CRANKS	SRAM S1400, BB30, 36/22
BOTTOM BRACKET	SRAM BB30
CHAIN	KMC X10SL
REAR COGS	SHIMANO M771, 11-36, 10-SPEED
FRONT DERAILLEUR	SRAM X7, DIRECT MOUNT
REAR DERAILLEUR	SHIMANO XT SHADOW+
SHIFTERS	SHIMANO XT, W/1-SPEC
HANDLEBAR	CANNONDALE C3 RISER, 740X18MM, 2014 ALLOY
GRIPS	CANNONDALE DUAL LOCKING GRIPS
STEM	CANNONDALE C1, 1.5", 31.8
HEADSET	TANGE SEIKI 1.5", INTEGRATED
BRAKES	SHIMANO XT TRAIL, 180/160MM
BRAKE LEVERS	SHIMANO XT TRAIL
SADDLE	WTB VOLT CROMO
SEATPOST	ROCKSHOX REVERB, 31.6X385MM HEIGHT ADJUSTABLE
SIZES	S, M, L, XL
COLOR (CODE)	JET BLACK, GLOSS (BLK)
EXTRAS	HIGH PRESSURE SHOCK PUMP, SYNTACE X-12MM REAR AXLE, MRP 2X GUIDE

JEKYLL 4	
PRODUCT CODE	C13VN4
FRAME	JEKYLL, 150MM, SMARTFORMED ALLOY, BB30, ISCG03, 1.5SI HEAD TUBE
FORK	ROCKSHOX SEKTOR TK DPC, 150MM, 15QR THRU AXLE, 1.5"
REAR SHOCK	XFUSION P1-RL 150MM, W/REMOTE LEVER
RIMS	WTB ST I19 TCS, TUBELESS READY
HUBS	FORMULA, 32 HOLE, 15MM THRU AXLE FRONT, 142X12MM REAR
SPOKES	DT SWISS COMPETITION
TIRES	WTB VIGILANTE 2.3 TCS FRONT, MOTO 2.3 TCS REAR, TUBELESS READY
PEDALS	N/A
CRANKS	SRAM S1000, BB30, 44/33/22
BOTTOM BRACKET	SRAM BB30
CHAIN	KMC X10
REAR COGS	SRAM PG-1030, 11-36, 10-SPEED
FRONT DERAILLEUR	SRAM X7, DIRECT MOUNT
REAR DERAILLEUR	SRAM X7
SHIFTERS	SHIMANO X5, 3X10-SPEED
HANDLEBAR	CANNONDALE C3 RISER, 740X18MM, 2014 ALLOY
GRIPS	CANNONDALE DUAL LOCKING GRIPS
STEM	CANNONDALE C1, 1.5", 31.8
HEADSET	TANGE SEIKI 1.5", INTEGRATED
BRAKES	MAGURA MT2, 180/160MM
BRAKE LEVERS	MAGURA MT2
SADDLE	CANNONDALE STAGE 3 CROMO
SEATPOST	CANNONDALE C2, 31.6X350MM
SIZES	S, M, L, XL
COLOR 1 (CODE)	MAGNESIUM WHITE, GLOSS (WHT)
COLOR 2 (CODE)	N/A
EXTRAS	HIGH PRESSURE SHOCK PUMP, SYNTACE X-12MM REAR AXLE

TRIGGER ULTIMATE	
PRODUCT CODE	C13VMO
FRAME	TRIGGER, 120/70MM, BALLISTEC HI-MOD CARBON, BB30, 1.5 SI HEADTUBE
FORK	LEFTY CARBON XLR 130 26, HYBRID NEEDLE BEARING TECHNOLOGY
REAR SHOCK	FOX DYAD RT2 DUAL SHOCK, 120/70MM, W/REMOTE LEVER
RIMS	ENVE COMPOSITES TWENTY6 AM, 28H, TUBELESS READY
HUBS	LEFTY SL FRONT, DT SWISS 240S 135X9MM REAR
SPOKES	DT SWISS AEROLITE
TIRES	SCHWALBE RACING RALPH EVO, 2.25" TUBELESS READY
PEDALS	N/A
CRANKS	CANNONDALE HOLLOWGRAM SL, BB30, 38/24 W/SRAM XO RINGS
BOTTOM BRACKET	CANNONDALE BB30
CHAIN	KMC X10SL
REAR COGS	SRAM XX, 11-36, 10-SPEED
FRONT DERAILLEUR	SRAM XO, DIRECT MOUNT
REAR DERAILLEUR	SRAM XX
SHIFTERS	SRAM XX
HANDLEBAR	TRUVATIVI NOIR T40 RISER, 720X15MM, CARBON
GRIPS	CANNONDALE DUAL LOCKING GRIPS
STEM	CANNONDALE OPI ADJUSTABLE, +6 DEGREE, 31.8
HEADSET	CANNONDALE HEADSHOK SI
BRAKES	AVID X0 CARBON, 180/160MM
BRAKE LEVERS	AVID X0 CARBON
SADDLE	PROLOGO X8 PRO T1.4
SEATPOST	FI'ZIK CYRANO CARBON 31.6X400MM
SIZES	S, M, L, XL
COLOR 1 (CODE)	EXPOSED CARBON W/ JET BLACK AND CHARCOAL GRAY ACCENTS/MATTE (CRB)
COLOR 2 (CODE)	N/A
EXTRAS	HIGH PRESSURE SHOCK PUMP

JEKYLL CARBON 1	
PRODUCT CODE	C13VN1
FRAME	JEKYLL, 150/90MM, BALLISTEC HI-MOD CARBON, BB30, ISCG03, 1.5 SI HEADTUBE
FORK	FOX 34 TALAS CTD, FIT, FACTORY, KASHIMA COATED, 160MM, 15QR THRU AXLE, 1.5"
REAR SHOCK	FOX DYAD RT2 DUAL SHOCK, 150/90MM, W/REMOTE LEVER
RIMS	REYNOLDS CARBON AM, TUBELESS READY
HUBS	REYNOLDS CARBON AM, 15MM FRONT, 142X12MM REAR
SPOKES	REYNOLDS CARBON AM
TIRES	SCHWALBE HANS DAMPF SNAKESKIN TRAILSTAR, 2.35" TUBELESS READY
PEDALS	N/A
CRANKS	SRAM S2210, BB30, 36/22
BOTTOM BRACKET	SRAM BB30
CHAIN	KMC X10SL
REAR COGS	SRAM PG-1070, 11-36, 10-SPEED
FRONT DERAILLEUR	SRAM X0, DIRECT MOUNT
REAR DERAILLEUR	SHIMANO XTR SHADOW+
SHIFTERS	SHIMANO XT, W/1-SPEC
HANDLEBAR	FSA GRAVITY LITE CARBON, 740X15MM RISE
GRIPS	CANNONDALE DUAL LOCKING GRIPS
STEM	FSA GRAVITY LITE, 1.5", 31.8
HEADSET	TANGE SEIKI 1.5", INTEGRATED
BRAKES	SHIMANO XTR TRAIL, 180/160MM
BRAKE LEVERS	SHIMANO XTR TRAIL
SADDLE	WTB VOLT NICO SL
SEATPOST	ROCKSHOX REVERB, 31.6X385MM HEIGHT ADJUSTABLE
SIZES	S, M, L, XL
COLOR (CODE)	JET BLACK W/ MAGNESIUM WHITE AND BERSERKER GREEN ACCENTS, GLOSS (BLK)
EXTRAS	HIGH PRESSURE SHOCK PUMP, SYNTACE X-12MM REAR AXLE, MRP 2X GUIDE

TRIGGER 29'ER 1	
PRODUCT CODE	C13VZ91
FRAME	TRIGGER 29'ER, 130/80MM, SMARTFORMED ALLOY, BB30, ISCG03, 1.5SI HEAD TUBE
FORK	SUPERMAX PBR 130 29, W/ HYBRID NEEDLE BEARING TECHNOLOGY
REAR SHOCK	FOX DYAD RT2 DUAL SHOCK, 130/80MM, W/REMOTE LEVER
RIMS	STAN'S ZTR CREST 29'ER, 32 HOLE, TUBELESS READY
HUBS	LEFTY SL FRONT, SHIMANO FHM-788 142X12MM REAR
SPOKES	DT SWISS COMPETITION
TIRES	SCHWALBE HANS DAMPF SNAKESKIN, 29X2.35", FOLDING
PEDALS	N/A
CRANKS	SRAM S1400, BB30, 36/22 W/GUARD

MOUNTAIN SPECIFICATIONS

TRIGGER 2	
PRODUCT CODE	C13VM2
FRAME	TRIGGER, 120/70MM, BALLISTEC HI-MOD CARBON, BB30, 1.5 SI HEADTUBE
FORK	LEFTY PBR 130 26, HYBRID NEEDLE BEARING TECHNOLOGY
REAR SHOCK	FOX DYAD RT2 DUAL SHOCK, 120/70MM, W/REMOTE LEVER
RIMS	MAVIC CROSSTRAIL, TUBELESS READY
HUBS	MAVIC CROSSTRAIL, LEFTY FRONT, 135X9MM REAR
SPOKES	MAVIC CROSSTRAIL
TIRES	SCHWALBE RACING RALPH PERFORMANCE, 2.25"
PEDALS	N/A
CRANKS	SRAM S1400, BB30, 38/24 W/GUARD
BOTTOM BRACKET	SRAM BB30
CHAIN	KMC X10
REAR COGS	SRAM PG-1070, 11-36, 10-SPEED
FRONT DERAILLEUR	SRAM X7, DIRECT MOUNT
REAR DERAILLEUR	SRAM X9 TYPE2 RBC
SHIFTERS	SRAM X9 W/MAGURA SHIFTMIX
HANDLEBAR	CANNONDALE C2 RISER, 700X20MM, 2014 ALLOY
GRIPS	CANNONDALE DUAL LOCKING GRIPS
STEM	CANNONDALE OPI ADJUSTABLE, +6 DEGREE, 31.8
HEADSET	CANNONDALE HEADSHOK SI
BRAKES	MAGURA MT2 W/BAT, 180/160MM
BRAKE LEVERS	MAGURA MT2 W/BAT
SADDLE	PROLOGO X8 PRO T1.4
SEATPOST	CANNONDALE C2, 31.6X400MM
SIZES	S, M, L, XL
COLOR (CODE)	MAGNESIUM WHITE W/ JET BLACK AND ULTRA BLUE ACCENTS, GLOSS (BLU)
EXTRAS	HIGH PRESSURE SHOCK PUMP

SCALPEL 29'ER 3	
PRODUCT CODE	C13VP93
FRAME	SCALPEL 29'ER, 100MM, SMARTFORMED ALLOY, BB30, 1.5 SI HEAD TUBE
FORK	LEFTY PBR 100 29, HYBRID NEEDLE BEARING TECHNOLOGY
REAR SHOCK	FOX, PERFORMANCE, CTD
RIMS	WTB ST I19, TCS, 32 HOLE, TUBELESS READY
HUBS	LEFTY SL FRONT, FORMULA DHL-142 142X12MM REAR
SPOKES	DT SWISS SUPER COMP
TIRES	SCHWALBE RACING RALPH PERFORMANCE, FOLDING
PEDALS	N/A
CRANKS	SRAM S1000, BB30, 38/24
BOTTOM BRACKET	SRAM BB30
CHAIN	KMC X10
REAR COGS	SRAM PG-1030, 11-36, 10-SPEED
FRONT DERAILLEUR	SRAM, X7, S3
REAR DERAILLEUR	SRAM, X9
SHIFTERS	SRAM X7
HANDLEBAR	CANNONDALE C2 FLAT, 680X3MM, 2014 ALLOY
GRIPS	CANNONDALE DUAL-DENSITY GRIP
STEM	CANNONDALE C1 HEADSHOK, 31.8
HEADSET	CANNONDALE HEADSHOK SI
BRAKES	AVID ELIXIR 5 180/160MM
BRAKE LEVERS	AVID ELIXIR 5
SADDLE	FI'ZI-K TUNDRA 2
SEATPOST	CANNONDALE C3, 31.6X400MM
SIZES	S, M, L, X
COLOR 1 (CODE)	MAGNESIUM WHITE, GLOSS (WHT)
COLOR 2 (CODE)	N/A

RZ120 XLR 1	
PRODUCT CODE	C13VLX1
FRAME	RZ ONE TWENTY, 120MM, SMARTFORMED ALLOY, BB30, 1.5 SI HEAD TUBE
FORK	LEFTY XLR 120 26, HYBRID NEEDLE BEARING TECHNOLOGY
REAR SHOCK	ROCKSHOX MONARCH RT3
RIMS	SUN RINGLE BLACK FLAG PRO, 24 HOLE, TUBELESS READY
HUBS	SUN RINGLE BLACK FLAG PRO LEFTY FRONT, 135X9MM REAR
SPOKES	SUN RINGLE BLACK FLAG PRO
TIRES	SCHWALBE RACING RALPH 26X2.25
PEDALS	N/A
CRANKS	SRAM S2210, BB30, 38/24
BOTTOM BRACKET	SRAM BB30
CHAIN	KMC X10SL, 10-SPEED
REAR COGS	SRAM PG 1070, 11-36, 10-SPEED
FRONT DERAILLEUR	SRAM X0, DIRECT MOUNT
REAR DERAILLEUR	SRAM XX, LONG CAGE
SHIFTERS	SRAM X0
HANDLEBAR	TRUVATIV NOIR T30 RISER, 700X25MM
GRIPS	CANNONDALE DUAL LOCKING GRIPS
STEM	CANNONDALE OPI ADJUSTABLE, +6 DEGREE, 31.8MM
HEADSET	CANNONDALE HEADSHOK SI
BRAKES	AVID ELIXIR 9 CARBON, 180/160MM
BRAKE LEVERS	AVID ELIXIR 9 CARBON
SADDLE	FI'ZI-K TUNDRA2 KM
SEATPOST	FI'ZI-K CYRANO CARBON, 31.6X400MM
SIZES	S, M, L, X
COLOR 1 (CODE)	JET BLACK W/MAGNESIUM WHITE, RACE RED ACCENTS, GLOSS (BLK)
COLOR 2 (CODE)	N/A

SCALPEL 29'ER CARBON ULTIMATE	
PRODUCT CODE	C13VP90
FRAME	SCALPEL 29'ER, 100MM, BALLISTEC HI-MOD CARBON, ZERO PIVOT SEATSTAY, BB30, 1.5 SI HEAD TUBE,
FORK	LEFTY CARBON XLR 100 29, HYBRID NEEDLE BEARING TECHNOLOGY
REAR SHOCK	FOX FACTORY CTD W/BOOST VALVE, KASHIMA COATING
RIMS	ENVE CARBON, TUBELESS READY
HUBS	LEFTY SL FRONT, DT SWISS 240S 142X12MM REAR
SPOKES	DT SWISS AEROLITE
TIRES	SCHWALBE RACING RALPH, 29X2.1 EVO, FOLDING
PEDALS	N/A
CRANKS	CANNONDALE HOLLOWGRAM SL, 39/26
BOTTOM BRACKET	CANNONDALE SI PRESSFIT BB30
CHAIN	KMC X10SL
REAR COGS	SHIMANO CS-M980, 11-36, 10-SPEED
FRONT DERAILLEUR	SRAM XX, S3
REAR DERAILLEUR	SHIMANO XTR
SHIFTERS	SHIMANO XTR
HANDLEBAR	ENVE, FLAT, 700MM
GRIPS	CANNONDALE LOCKING GRIPS
STEM	CANNONDALE OPI ADJUSTABLE -15 DEGREE, 31.8
HEADSET	CANNONDALE HEADSHOK SI
BRAKES	MAGURA MT8 160/160MM
BRAKE LEVERS	MAGURA CARBON
SADDLE	PROLOGO SCRATCH X8 CBN RAIL
SEATPOST	FI'ZI-K CYRANO, 31.6X400MM
SIZES	S, M, L, X
COLOR (CODE)	EXPOSED CARBON, MATTE (CRB)
EXTRAS	SINGLE RING CONVERSION KIT (MRP 36T RING & MRP SINGLE GUIDE) INCLUDED

SCALPEL 29'ER 4	
PRODUCT CODE	C13VP94
FRAME	SCALPEL 29'ER, 100MM, SMARTFORMED ALLOY, BB30, 1.5 SI HEAD TUBE
FORK	ROCKSHOX RECON GOLD TK 29, 80MM, SOLO AIR, LOCKOUT, REBOUND, 1.5"
REAR SHOCK	X FUSION E1 RL
RIMS	SUN RINGLE INFERNO25, WELDED, W/EYELET, 32 HOLE
HUBS	FORMULA 15MM FRONT, 142X12MM REAR
SPOKES	DT SWISS
TIRES	KENDA SMALL BLOC K 8, 2.1" FOLDING
PEDALS	N/A
CRANKS	FSA COMET, BB30, 42/32/24
BOTTOM BRACKET	SRAM BB30
CHAIN	KMC X10
REAR COGS	SHIMANO TIAGRA 4600, 12-28, 10-SPEED
FRONT DERAILLEUR	SHIMANO HG-62, 11-36, 10-SPEED
REAR DERAILLEUR	SHIMANO SLX, E-TYPE
SHIFTERS	SHIMANO XT / SHIMANO DEORE
HANDLEBAR	CANNONDALE C3 RISER, 700X15MM, 6061
GRIPS	CANNONDALE DUAL-DENSITY GRIP
STEM	CANNONDALE C3, 1.5", 31.8
HEADSET	TANGE 1.5 SI
BRAKES	AVID ELIXIR 3, 180/160MM
BRAKE LEVERS	AVID ELIXIR 3
SADDLE	CANNONDALE STAGE 3 CROMO
SEATPOST	CANNONDALE C3, 31.6X400MM
SIZES	S, M, L, X
COLOR 1 (CODE)	JET BLACK, GLOSS (BLK)
COLOR 2 (CODE)	N/A

RZ120 XLR 2	
PRODUCT CODE	C13VLX2
FRAME	RZ ONE TWENTY, 120MM, SMARTFORMED ALLOY, BB30, 1.5 SI HEAD TUBE
FORK	LEFTY XLR 120 26, HYBRID NEEDLE BEARING TECHNOLOGY
REAR SHOCK	FOX FLOAT CTD PERFORMANCE
RIMS	STANS ZTR CREST 26, 32H, TUBELESS READY
HUBS	LEFTY SL FRONT, SUN RINGLE DIRTY FLEA 135X9MM REAR
SPOKES	DT SWISS
TIRES	SCHWALBE RACING RALPH 26X2.25
PEDALS	N/A
CRANKS	SRAM S2210, BB30, 44/33/22
BOTTOM BRACKET	SRAM BB30
CHAIN	KMC X10SL, 10-SPEED
REAR COGS	SRAM PG 1030, 11-36, 10-SPEED
FRONT DERAILLEUR	SRAM X9, DIRECT MOUNT
REAR DERAILLEUR	SHIMANO XTR, SHADOW+
SHIFTERS	SHIMANO XT
HANDLEBAR	CANNONDALE C2 RISER, 680X20MM, 2014 ALLOY
GRIPS	CANNONDALE DUAL LOCKING GRIPS
STEM	CANNONDALE OPI ADJUSTABLE, +6 DEGREE, 31.8MM
HEADSET	CANNONDALE HEADSHOK SI
BRAKES	MAGURA MT4, 180/160MM
BRAKE LEVERS	MAGURA MT4
SADDLE	FI'ZI-K TUNDRA2 MG
SEATPOST	CANNONDALE C2, 31.6X400MM
SIZES	S, M, L, X
COLOR 1 (CODE)	JET BLACK W/ MAG WHITE, ULTRA BLUE, RACE RED ACCENTS, GLOSS (BLU)
COLOR 2 (CODE)	N/A

SCALPEL 29'ER CARBON 1	
PRODUCT CODE	C13VP91
FRAME	SCALPEL 29'ER, 100MM, BALLISTEC HI-MOD CARBON, ZERO PIVOT SEATSTAY, BB30, 1.5 SI HEAD TUBE,
FORK	LEFTY CARBON XLR 100 29, HYBRID NEEDLE BEARING TECHNOLOGY
REAR SHOCK	SRAM XX SHOCK W/X-LOC REMOTE LOCKOUT
RIMS	REYNOLDS CARBON 29'ER, TUBELESS READY
HUBS	REYNOLDS LEFTY, REYNOLDS 142X12MM REAR
SPOKES	REYNOLDS
TIRES	SCHWALBE RACING RALPH, 29X2.1 EVO, FOLDING
PEDALS	N/A
CRANKS	SRAM X0, BB30, 38/24
BOTTOM BRACKET	SRAM PRESSFIT BB30
CHAIN	KMC X10SL
REAR COGS	SRAM PG-1070, 11-36, 10-SPEED
FRONT DERAILLEUR	SRAM, X0, S3
REAR DERAILLEUR	SRAM, X0
SHIFTERS	SRAM X0
HANDLEBAR	TRU VATI V NOIR FLAT, 700X10MM
GRIPS	CANNONDALE DUAL-DENSITY GRIP
STEM	CANNONDALE OPI ADJUSTABLE -15 DEGREE, 31.8
HEADSET	CANNONDALE HEADSHOK SI
BRAKES	AVID X0 CARBON 180 / 180MM
BRAKE LEVERS	AVID X0 CARBON
SADDLE	PROLOGO SCRATCH X8 PRO
SEATPOST	FI'ZI-K CYRANO, 31.6X400MM
SIZES	S, M, L, X
COLOR (CODE)	EXPOSED CARBON W/MAGNESIUM WHITE AND ULTRA BLUE, GLOSS (BLK)
EXTRAS	N/A

SCALPEL 2	
PRODUCT CODE	C13VP2
FRAME	SCALPEL 80MM, BALLISTEC HI-MOD FULL CARBON, ZERO PIVOT, BB30, 1.5 SI HEAD TUBE
FORK	LEFTY XLR 100 26, HYBRID NEEDLE BEARING TECHNOLOGY
REAR SHOCK	ROCKSHOX MONARCH RL 80MM
RIMS	MAVIC CROSSTRAIL, TUBELESS READY
HUBS	MAVIC CROSSTRAIL LEFTY FRONT, CROSSTRAIL 135X9MM REAR
SPOKES	MAVIC CROSSTRAIL
TIRES	SCHWALBE RACING RALPH EVO FOLDING 26X2.1, TUBELESS READY
PEDALS	N/A
CRANKS	SRAM S2210, BB30, 42/28
BOTTOM BRACKET	SRAM BB30
CHAIN	KMC X10SL
REAR COGS	SHIMANO 105 5700, 11-28, 10-SPEED
FRONT DERAILLEUR	SRAM PG-1070, 11-36, 10-SPEED
REAR DERAILLEUR	SRAM X0, 10-SPEED
SHIFTERS	SRAM X9, 10-SPEED / SRAM X9
HANDLEBAR	TRUVATIV NOIR RISER, 680X20
GRIPS	CANNONDALE FOAM LOCKING GRIPS
STEM	CANNONDALE OPI ADJUSTABLE -5(S-L), +6 (XL) 31.8
HEADSET	CANNONDALE HEADSHOK SI
BRAKES	AVID ELIXIR 9 CARBON 160/140MM
BRAKE LEVERS	AVID ELIXIR 9 CARBON
SADDLE	FI'ZI-K TUNDRA2 MAG
SEATPOST	FI'ZI-K CYRANO, 31.6X400MM
SIZES	S, M, L, X
COLOR (CODE)	EXPOSED CARBON W/ MAGNESIUM WHITE AND BERSERKER GREEN ACCENTS, GLOSS (GRN)
EXTRAS	N/A

RZ120 XLR 3	
PRODUCT CODE	C13VLX3
FRAME	RZ ONE TWENTY, 120MM, SMARTFORMED ALLOY, BB30, 1.5 SI HEAD TUBE
FORK	LEFTY PBR 120 26, HYBRID NEEDLE BEARING TECHNOLOGY
REAR SHOCK	FOX FLOAT CTD EVOLUTION
RIMS	WTB FREQUENCY RACE I19, 32H, TCS, TUBELESS READY
HUBS	LEFTY SL FRONT, FORMULA DC22 135X9MM REAR
SPOKES	DT SWISS
TIRES	SCHWALBE RACING RALPH 26X2.25
PEDALS	N/A
CRANKS	SRAM S1000, BB30, 44/33/22
BOTTOM BRACKET	SRAM BB30
CHAIN	KMC X10, 10-SPEED
REAR COGS	SRAM PG 1030, 11-36, 10-SPEED
FRONT DERAILLEUR	SRAM X7, DIRECT MOUNT
REAR DERAILLEUR	SRAM X9 CARBON
SHIFTERS	SRAM X9
HANDLEBAR	CANNONDALE C2 RISER, 680X20MM, 2014 ALLOY
GRIPS	CANNONDALE DUAL LOCKING GRIPS
STEM	CANNONDALE C3, 1.5, 5 DEGREE, 31.8MM
HEADSET	CANNONDALE HEADSHOK SI
BRAKES	AVID ELIXIR 5, 180/160MM
BRAKE LEVERS	AVID ELIXIR 5
SADDLE	FI'ZI-K TUNDRA2
SEATPOST	CANNONDALE C3, 31.6X400MM
SIZES	S, M, L, X
COLOR 1 (CODE)	JET BLACK W/CHARCOAL GRAY AND MAG WHITE ACCENTS, MATTE (BBQ)
COLOR 2 (CODE)	N/A

SCALPEL 29'ER CARBON 2	
PRODUCT CODE	C13VP92
FRAME	SCALPEL 29'ER, 100MM, BALLISTEC HI-MOD CARBON, ZERO PIVOT SEATSTAY, BB30, 1.5 SI HEAD TUBE,
FORK	LEFTY XLR 100 29, HYBRID NEEDLE BEARING TECHNOLOGY
REAR SHOCK	ROCKSHOX MONARCH RT3
RIMS	STAN'S ZTR ARCH EX 29'ER, 32 HOLE
HUBS	LEFTY SI FRONT, SUN RINGLE DIRTY FLEA REAR 142X12MM REAR
SPOKES	DT SWISS SUPER COMP
TIRES	SCHWALBE RACING RALPH, 29X2.1 EVO, FOLDING
PEDALS	N/A
CRANKS	SRAM S2210, BB30, 38/24
BOTTOM BRACKET	SRAM PRESS FIT BB30
CHAIN	KMC X10
REAR COGS	SRAM PG-1070, 11-36, 10-SPEED
FRONT DERAILLEUR	SRAM, X9, S3
REAR DERAILLEUR	SHIMANO XTR
SHIFTERS	SHIMANO XT
HANDLEBAR	TRU VATIV NOIR FLAT, 700X10MM
GRIPS	CANNONDALE DUAL-DENSITY GRIP
STEM	CANNONDALE OPI ADJUSTABLE -15 DEGREE, 31.8
HEADSET	CANNONDALE HEADSHOK SI
BRAKES	AVID ELIXIR 9 CARBON, 180/160MM
BRAKE LEVERS	AVID ELIXIR 9 CARBON
SADDLE	PROLOGO X8
SEATPOST	FI'ZI-K CYRANO, 31.6X400MM
SIZES	S, M, L, X
COLOR (CODE)	EXPOSED CARBON W/ MAGNESIUM WHITE AND BERSERKER GREEN ACCENTS, GLOSS (GRN)
EXTRAS	EXPOSED CARBON W/ BERSERKER GREEN (REP)

SCALPEL 3	
PRODUCT CODE	C13VP3
FRAME	SCALPEL 80MM, BALLISTEC HI-MOD FULL CARBON, ZERO PIVOT, BB30, 1.5 SI HEAD TUBE
FORK	LEFTY PBR 100 26, HYBRID NEEDLE BEARING TECHNOLOGY
REAR SHOCK	FOX PERFORMANCE CTD
RIMS	WTB PHASE I19 TCS, TUBELESS READY
HUBS	WTB LEFTY FRONT, WTB PHASE I19 135X9MM REAR
SPOKES	WTB
TIRES	SCHWALBE RACING RALPH 26X2.1
PEDALS	N/A
CRANKS	SRAM S1400, BB30, 42/28
BOTTOM BRACKET	SRAM BB30
CHAIN	KMC X10
REAR COGS	SRAM PG-1030, 11-36, 10-SPEED
FRONT DERAILLEUR	SRAM PG-1030, 11-36, 10-SPEED
REAR DERAILLEUR	SRAM X7, S3
SHIFTERS	SHIMANO XT SHADOW PLUS / SHIMANO SLX I-SPEC
HANDLEBAR	CANNONDALE C2 RISER, 700X20MM, 2014 ALLOY
GRIPS	CANNONDALE FOAM LOCKING GRIPS
STEM	CANNONDALE OPI ADJUSTABLE -5(S-L), +6 (XL) 31.8
HEADSET	CANNONDALE HEADSHOK SI
BRAKES	AVID ELIXIR 7 160/140MM
BRAKE LEVERS	AVID ELIXIR 7
SADDLE	FI'ZI-K TUNDRA 2
SEATPOST	CANNONDALE C2, 31.6X400MM
SIZES	S, M, L, X
COLOR (CODE)	EXPOSED CARBON W/ MAGNESIUM WHITE AND BERSERKER GREEN ACCENTS, GLOSS (GRN)
EXTRAS	HIGH PRESSURE SHOCK PUMP, DYAD

MOUNTAIN SPECIFICATIONS

	RZ120 2
PRODUCT CODE	C13VL2
FRAME	RZ ONE TWENTY, 120MM SMARTFORMED ALLOY, BB30, 1.5 SI HEAD TUBE
FORK	X-FUSION ENIX RL, 120MM, LOCKOUT, REBOUND, 1.5"
REAR SHOCK	X-FUSION E1 RL 120MM
RIMS	MADDUX DC3.0, DOUBLE WALL W/ EYELET
HUBS	FORMULA DC20 FRONT, DC22 135X9MM REAR
SPOKES	DT SWISS CHAMPION
TIRES	SCHWALBE RAPID ROB 26X2.25
PEDALS	N/A
CRANKS	SHIMANO M552 42/32/24
BOTTOM BRACKET	FSA
CHAIN	KMC X10
REAR COGS	SRAM PG-1030, 11-36, 10-SPEED
FRONT DERAILLEUR	SHIMANO DEORE, 34.9 DOWN SWING
REAR DERAILLEUR	SHIMANO SLX, 10-SPEED
SHIFTERS	SHIMANO DEORE W/GEAR DISPLAY
HANDLEBAR	CANNONDALE C3, 700X20, 6061 DOUBLE-BUTTED ALLOY
GRIPS	CANNONDALE LOCKING GRIPS
STEM	CANNONDALE CA, 1.5", 31.8"
HEADSET	TANGE SEIKI, 1.5", 31.8"
BRAKES	AVID ELIXIR 1, 180/160MM
BRAKE LEVERS	AVID ELIXIR 1
SADDLE	CANNONDALE STAGE 3
SEATPOST	CANNONDALE C3, 31.6X350MM
SIZES	S,M,L,X
COLOR 1 (CODE)	MAGNESIUM WHITE, GLOSS (WHT)
COLOR 2 (CODE)	JET BLACK, MATTE (BBQ)
EXTRAS	N/A

	F29 CARBON 3
PRODUCT CODE	C13FS293S
FRAME	F29, BALLISTEC CARBON, SPEED SAVE, BB30, 1.5 SI HEAD TUBE
FORK	LEFTY PBR 90 29, HYBRID NEEDLE BEARING TECHNOLOGY
REAR SHOCK	N/A
RIMS	WTB FREQUENCY RACE I19, TCS, 32-HOLE, TUBELESS READY
HUBS	FORMULA LEFTY SL FRONT, SHIMANO FH-M525, REAR
SPOKES	DT SWISS COMPETITION
TIRES	SCHWALBE RACING RALPH PERFORMANCE, 29X2.1" EVO TUBELESS READY
PEDALS	N/A
CRANKS	SRAM S1000, BB30, 38/24
BOTTOM BRACKET	SRAM BB30
CHAIN	KMC X10
REAR COGS	SRAM PG-1030, 11-36, 10-SPEED
FRONT DERAILLEUR	SRAM X7, S3
REAR DERAILLEUR	SHIMANO XT, 10-SPEED
SHIFTERS	SHIMANO SLX
HANDLEBAR	CANNONDALE C2, 680X10, 2014 DOUBLE-BUTTED ALLOY
GRIPS	CANNONDALE LOCKING GRIPS
STEM	CANNONDALE OPI ADJUSTABLE, 31.8, -15 DEGREE(M-L), -5 DEGREE(X)
HEADSET	TANGE HS BEARINGS 2X
BRAKES	AVID ELX 7, 180/160MM
BRAKE LEVERS	AVID ELX 7
SADDLE	FI'ZI:K TUNDRA 2
SEATPOST	CANNONDALE C2, 27.2MMX400MM,
SIZES	M, L, XL
COLOR 1 (CODE)	EXPOSED CARBON W/ MAGNESIUM WHITE AND BERSERKER GREEN ACCENTS, GLOSS (WHT)
COLOR 2 (CODE)	N/A

	F26 CARBON 3
PRODUCT CODE	C13FS3S
FRAME	F26, BALLISTEC CARBON, SPEED SAVE, BB30, 1.5 SI HEAD TUBE
FORK	CANNONDALE FATTY DLR80, 80MM
REAR SHOCK	N/A
RIMS	SHIMANO MT66
HUBS	SHIMANO MT66
SPOKES	SHIMANO MT66
TIRES	SCHWALBE RACING RALPH PERFORMANCE, 26X2.1"
PEDALS	N/A
CRANKS	SRAM S1400, BB30, 42/28
BOTTOM BRACKET	SRAM BB30
CHAIN	KMC X10SL
REAR COGS	SRAM PG-1030, 11-36, 10-SPEED
FRONT DERAILLEUR	SRAM X7, S3
REAR DERAILLEUR	SHIMANO XT SHADOW PLUS, 10-SPEED
SHIFTERS	SHIMANO SLX
HANDLEBAR	CANNONDALE C2, 680X20, 2014 DOUBLE-BUTTED ALLOY
GRIPS	CANNONDALE LOCKING GRIPS
STEM	CANNONDALE C1 HEADSHOK, 5 DEGREE, 31.8
HEADSET	TANGE HEADSHOK BEARING
BRAKES	AVID ELIXIR 7, 160/140MM
BRAKE LEVERS	AVID ELIXIR 7
SADDLE	FI'ZI:K TUNDRA 2 MG RAIL
SEATPOST	CANNONDALE C2, 27.2X400MM
SIZES	S, M, L
COLOR 1 (CODE)	EXPOSED CARBON W/ MAGNESIUM WHITE AND BERSERKER GREEN ACCENTS, GLOSS (GRN)
COLOR 2 (CODE)	N/A

	F29 CARBON HI-MOD ULTIMATE
PRODUCT CODE	C13FS290S
FRAME	F29, BALLISTEC HI-MOD CARBON, SPEED SAVE, BB30, 1.5 SI HEAD TUBE
FORK	LEFTY CARBON XLR 90 29, HYBRID NEEDLE BEARING TECHNOLOGY
REAR SHOCK	N/A
RIMS	ENVE CARBON, TUBELESS READY
HUBS	LEFTY SL FRONT, DT SWISS 240S 142X12MM REAR
SPOKES	DT SWISS AEROLITE
TIRES	SCHWALBE RACING RALPH EVO, 29X2.1" EVO TUBELESS READY
PEDALS	N/A
CRANKS	CANNONDALE HOLLOWGRAM SL, 39/26
BOTTOM BRACKET	CANNONDALE SI BB30
CHAIN	KMC X10SL
REAR COGS	SRAM XX, 11-36, 10-SPEED
FRONT DERAILLEUR	SRAM XX S3
REAR DERAILLEUR	SRAM XX, 10-SPEED
SHIFTERS	SRAM XX
HANDLEBAR	ENVE CARBON FLAT, 700MM
GRIPS	CANNONDALE FOAM LOCKING GRIPS
STEM	CANNONDALE OPI ADJUSTABLE, 31.8, -15 DEGREE(M-L), -5 DEGREE(X)
HEADSET	TANGE HS BEARINGS 2X
BRAKES	MAGURA MT8, 160/140MM
BRAKE LEVERS	MAGURA MT8
SADDLE	FI'ZI:K TUNDRA 2
SEATPOST	CANNONDALE SAVE POST, 27.2X420MM
SIZES	M, L, XL
COLOR 1 (CODE)	EXPOSED CARBON W/ NEARLY BLACK AND CHARCOAL GRAY ACCENTS, MATTE (CRB)
COLOR 2 (CODE)	N/A
EXTRAS	SINGLE RING CONVERSION KIT (MRP 36T RING & MRP SINGLE GUIDE) INCLUDED

	F29 1
PRODUCT CODE	C13FA291
FRAME	F29, SMARTFORMED ALLOY, SPEED SAVE, BB30, 1.5 SI HEAD TUBE
FORK	LEFTY PBR 90 29, HYBRID NEEDLE BEARING TECHNOLOGY
REAR SHOCK	N/A
RIMS	WTB ST I19, WELDED, EYELET, 32 HOLE, TUBELESS READY
HUBS	FORMULA LEFTY SL FRONT, SRAM X9, REAR
SPOKES	DT SWISS COMPETITION
TIRES	SCHWALBE RAPID ROB, 29X2.5"
PEDALS	N/A
CRANKS	SRAM S1400 BB30, 38/24
BOTTOM BRACKET	SRAM BB30
CHAIN	KMC X10
REAR COGS	SRAM PG 1030, 11-36, 10-SPEED
FRONT DERAILLEUR	SRAM X7, 31.6 CLAMP
REAR DERAILLEUR	SRAM X9, 10-SPEED
SHIFTERS	SRAM X9
HANDLEBAR	CANNONDALE C2, 680X10, 2014 DOUBLE-BUTTED ALLOY
GRIPS	CANNONDALE DUAL-DENSITY GRIP
STEM	CANNONDALE OPI ADJUSTABLE, 31.8, -15 DEGREE(M-L), -5 DEGREE(X)
HEADSET	TANGE HS BEARINGS 2X
BRAKES	AVID ELIXIR 7, 180/160MM
BRAKE LEVERS	AVID ELIXIR
SADDLE	CANNONDALE STAGE 3
SEATPOST	CANNONDALE C2, 27.2MMX400MM,
SIZES	S, M, L, XL
COLOR 1 (CODE)	MAGNESIUM WHITE, GLOSS (WHT)
COLOR 2 (CODE)	N/A

	F26 1
PRODUCT CODE	C13FA1
FRAME	F26, SMARTFORMED ALLOY, SPEED SAVE, BB30, 1.5 SI HEAD TUBE
FORK	LEFTY PBR 100 26, HYBRID NEEDLE BEARING TECHNOLOGY
REAR SHOCK	N/A
RIMS	MAVIC XM319, 28 HOLE
HUBS	FORMULA LEFTY SL FRONT, SRAM X9 REAR
SPOKES	DT SWISS COMPETITION
TIRES	SCHWALBE RACING RALPH, 26X2.1" PACE STAR
PEDALS	N/A
CRANKS	SRAM S1400, BB30, 39/26
BOTTOM BRACKET	SRAM BB30
CHAIN	KMC X10
REAR COGS	SRAM PG-1030, 11-36, 10-SPEED
FRONT DERAILLEUR	SRAM X7, 31.8 CLAMP
REAR DERAILLEUR	SRAM X9, 10-SPEED
SHIFTERS	SRAM X9
HANDLEBAR	CANNONDALE C2, 680X20, 2014 DOUBLE-BUTTED ALLOY
GRIPS	CANNONDALE LOCKING GRIPS
STEM	CANNONDALE OPI 1.5", 31.8, -5 DEGREE
HEADSET	TANGE HS BEARINGS 2X
BRAKES	MAGURA MT2, 160/160MM
BRAKE LEVERS	MAGURA MT2
SADDLE	CANNONDALE STAGE 3
SEATPOST	CANNONDALE C2, 27.2X400MM
SIZES	S,M,L,X
COLOR 1 (CODE)	MAGNESIUM WHITE, GLOSS (WHT)
COLOR 2 (CODE)	N/A

	F29 CARBON HI-MOD 1
PRODUCT CODE	C13FS291S
FRAME	F29, BALLISTEC HI-MOD CARBON, SPEED SAVE, BB30, 1.5 SI HEAD TUBE
FORK	LEFTY CARBON XLR 90 29, HYBRID NEEDLE BEARING TECHNOLOGY
REAR SHOCK	N/A
RIMS	REYNOLDS CARBON WHEELSET, TUBELESS READY
HUBS	REYNOLDS CARBON WHEELSET
SPOKES	REYNOLDS CARBON WHEELSET
TIRES	SCHWALBE RACING RALPH EVO, 29X2.1" EVO TUBELESS READY
PEDALS	N/A
CRANKS	SRAM S2210, BB30, 38/24
BOTTOM BRACKET	SRAM BB30
CHAIN	KMC X10SL
REAR COGS	SRAM PG-1070, 11-36, 10-SPEED
FRONT DERAILLEUR	SRAM X0, S3,
REAR DERAILLEUR	SHIMANO XTR, SHADOW PLUS, 11-36, 10-SPEED
SHIFTERS	SHIMANO XTR
HANDLEBAR	TRUVATIV NOIR CARBON, T30 FLAT, 700X10MM
GRIPS	CANNONDALE FOAM LOCKING GRIPS
STEM	CANNONDALE OPI ADJUSTABLE, 31.8, -15 DEGREE(M-L), -5 DEGREE(X)
HEADSET	TANGE HS BEARINGS 2X
BRAKES	SRAM XO, 180/160MM
BRAKE LEVERS	SRAM XO
SADDLE	FI'ZI:K TUNDRA KM KIUM RAIL
SEATPOST	CANNONDALE SAVE POST, 27.2X420MM
SIZES	M, L, XL
COLOR 1 (CODE)	MAGNESIUM WHITE W/ RACE RED AND ULTRA BLUE ACCENTS, GLOSS (RED)
COLOR 2 (CODE)	EXPOSED CARBON W/ BERSERKER GREEN (REP)
EXTRAS	N/A

	F29 2
PRODUCT CODE	C13FA292
FRAME	F29, SMARTFORMED ALLOY, SPEED SAVE, BB30, 1.5 SI HEAD TUBE
FORK	LEFTY PBR 90 29, HYBRID NEEDLE BEARING TECHNOLOGY
REAR SHOCK	N/A
RIMS	WTB FREQUENCY RACE I19, WELDED, EYELET, 32 HOLE, TUBELESS READY
HUBS	FORMULA LEFTY SL FRONT, SHIMANO FH-M525, REAR
SPOKES	DT SWISS COMPETITION
TIRES	WTB NINE LINE 29X2.0" TCS
PEDALS	N/A
CRANKS	SHIMANO M552, 42/32/24
BOTTOM BRACKET	SHIMANO OCTALINK W/BB30 ADAPTOR
CHAIN	KMC X10
REAR COGS	SHIMANO HG62, 11-36, 10-SPEED
FRONT DERAILLEUR	SHIMANO DEORE 31.8 CHAMP
REAR DERAILLEUR	SHIMANO XT, 10-SPEED
SHIFTERS	SHIMANO SLX
HANDLEBAR	CANNONDALE C3, 700X15MM, 6061 DOUBLE-BUTTED ALLOY
GRIPS	CANNONDALE DUAL-DENSITY GRIP
STEM	CANNONDALE C3 HEADSHOK, 31.8, -5 DEGREE
HEADSET	HEADSHOK BEARINGS
BRAKES	MAGURA MT2, 180/160MM
BRAKE LEVERS	MAGURA MT2
SADDLE	CANNONDALE STAGE 3
SEATPOST	CANNONDALE C2, 27.2MMX400MM,
SIZES	S, M, L, XL
COLOR 1 (CODE)	JET BLACK, MATTE (BBQ)
COLOR 2 (CODE)	MAGNESIUM WHITE, GLOSS (WHT)

	F26 3
PRODUCT CODE	C13FA3
FRAME	F26, SMARTFORMED ALLOY, SPEED SAVE, BB30, 1.5 SI HEAD TUBE
FORK	CANNONDALE FATTY DLR80, 80MM, 1.5"
REAR SHOCK	N/A
RIMS	MADDUX X320 W/ EYELET, 28 HOLE FRONT, 32 HOLE REAR
HUBS	FORMULA DC20LW FRONT, DC22 REAR
SPOKES	DT SWISS CHAMPION
TIRES	SCHWALBE RAPID ROB, 26X2.1"
PEDALS	N/A
CRANKS	SHIMANO M552, 42/32/24
BOTTOM BRACKET	SHIMANO OCTALINK W/BB30 ADAPTOR
CHAIN	KMC X10
REAR COGS	SHIMANO HG62, 11-36, 10-SPEED
FRONT DERAILLEUR	SHIMANO DEORE, 31.8 CLAMP
REAR DERAILLEUR	SHIMANO XT, SHADOW PLUS, 10-SPEED
SHIFTERS	SHIMANO SLX
HANDLEBAR	CANNONDALE C3, 680X20, 6061 DOUBLE-BUTTED ALLOY
GRIPS	CANNONDALE DUAL-DENSITY GRIP
STEM	CANNONDALE C3 HEADSHOK, 31.8
HEADSET	TANGE HS BEARINGS 2X
BRAKES	SHIMANO M596 DEORE, 160/160MM
BRAKE LEVERS	SHIMANO M596 DEORE
SADDLE	CANNONDALE STAGE 3
SEATPOST	CANNONDALE C2, 27.2X350MM(S-M), 400MM(L-X),
SIZES	S,M,L,X
COLOR 1 (CODE)	JET BLACK, MATTE (BBQ)
COLOR 2 (CODE)	N/A

	F29 CARBON 2
PRODUCT CODE	C13FS292S
FRAME	F29, BALLISTEC CARBON, SPEED SAVE, BB30, 1.5 SI HEAD TUBE
FORK	LEFTY XLR 90 29, HYBRID NEEDLE BEARING TECHNOLOGY
REAR SHOCK	N/A
RIMS	NOTUBES ZTR ARCH EX 29'ER, 32-HOLE, TUBELESS READY
HUBS	FORMULA LEFTY SL FRONT, SUN RINGLE DIRTY FLEA REAR
SPOKES	DT SWISS AEROSPEED
TIRES	SCHWALBE RACING RALPH EVO, 29X2.1" EVO TUBELESS READY
PEDALS	N/A
CRANKS	SRAM S2210, BB30, 38/24
BOTTOM BRACKET	SRAM BB30
CHAIN	KMC X10
REAR COGS	SRAM PG-1070, 11-36, 10-SPEED
FRONT DERAILLEUR	SRAM X7, S3
REAR DERAILLEUR	SRAM X0, 10-SPEED
SHIFTERS	SRAM X9
HANDLEBAR	TRUVATIV NOIR CARBON, T30 FLAT, 700X10MM
GRIPS	CANNONDALE FOAM LOCKING GRIPS
STEM	CANNONDALE OPI ADJUSTABLE, 31.8, -15 DEGREE(M-L), -5 DEGREE(X)
HEADSET	TANGE HS BEARINGS 2X
BRAKES	AVID ELX 9, 180/160MM
BRAKE LEVERS	AVID ELX 9
SADDLE	FI'ZI:K TUNDRA 2 MG, MANGANESE RAIL
SEATPOST	CANNONDALE SAVE POST, 27.2X420MM
SIZES	M, L, XL
COLOR 1 (CODE)	MAGNESIUM WHITE W/ CHARCOAL GRAY AND RUBY RED ACCENTS, GLOSS (GRY)
COLOR 2 (CODE)	N/A
EXTRAS	N/A

	F26 HI-MOD CARBON 2
PRODUCT CODE	C13FS2S
FRAME	F26, HI-MOD BALLISTEC CARBON, SPEED SAVE, BB30, 1.5 SI HEAD TUBE
FORK	LEFTY XLR 100 26, HYBRID NEEDLE BEARING TECHNOLOGY
REAR SHOCK	N/A
RIMS	MAVIC CROSSTAIL WHEELSET, TUBELESS READY
HUBS	MAVIC CROSSTAIL WHEELSET
SPOKES	MAVIC CROSSTAIL WHEELSET
TIRES	SCHWALBE RACING RALPH EVO, 26X2.1" TUBELESS READY
PEDALS	N/A
CRANKS	SRAM S1400, BB30, 42/28
BOTTOM BRACKET	SRAM BB30
CHAIN	KMC X10SL
REAR COGS	SRAM PG-1070, 11-36, 10-SPEED
FRONT DERAILLEUR	SRAM X9, S3
REAR DERAILLEUR	SRAM X0, 10-SPEED
SHIFTERS	SRAM X9
HANDLEBAR	TRUVATIV NOIR T30 CARBON, 700X10
GRIPS	CANNONDALE FOAM LOCKING GRIPS
STEM	CANNONDALE OPI, 1.5", 31.8, -5 (S-L), +6 (L)
HEADSET	TANGE HEADSHOK BEARING
BRAKES	AVID ELIXIR 9, 160/140MM
BRAKE LEVERS	AVID ELIXIR 9
SADDLE	FI'ZI:K TUNDRA 2 MG RAIL
SEATPOST	CANNONDALE CARBON SAVE, 27.2X420MM
SIZES	S, M, L
COLOR 1 (CODE)	EXPOSED CARBON W/ MAGNESIUM WHITE AND BERSERKER GREEN ACCENTS, GLOSS (GRN)
COLOR 2 (CODE)	N/A

	TRAIL SL 29'ER 1
PRODUCT CODE	C13FS291
FRAME	TRAIL SL 29'ER, OPTIMIZED 6061 ALLOY, SAVE, 1.5" HEADTUBE
FORK	ROCKSHOX RECON GOLD TK 29, 80MM, SOLO AIR, LOCKOUT

MOUNTAIN SPECIFICATIONS

TRAIL SL 29"ER 2	
PRODUCT CODE	C13FS292
FRAME	TRAIL SL 29"ER, OPTIMIZED 6061 ALLOY, SAVE, 1.5" HEADTUBE
FORK	ROCKSHOX RECON SILVER TK 29, 80MM, SOLO AIR, LOCKOUT, REBOUND, 1.5"
REAR SHOCK	N/A
RIMS	MADDUX DC3.0 29"ER, DOUBLE WALL W/EYELET, 32 HOLE
HUBS	FORMULA CDH20 FRONT, FORMULA CDH22 REAR
SPOKES	STAINLESS STEEL, 15G BLACK
TIRES	WTB NINELINE, 29X2.0"
PEDALS	FPD PLATFORM
CRANKS	SHIMANO M522, 42/32/24
BOTTOM BRACKET	SHIMANO BB-ES25, OCTALINK
CHAIN	KMC X10
REAR COGS	SHIMANO HG-62, 11-36, 10-SPEED
FRONT DERAILLEUR	SHIMANO DEORE, 31.8 CLAMP
REAR DERAILLEUR	SHIMANO SLX, 10-SPEED
SHIFTERS	SHIMANO DEORE W/GEAR DISPLAY
HANDLEBAR	CANNONDALE C3, 680X20, 6061 DOUBLE-BUTTED ALLOY
GRIPS	CANNONDALE LOCKING GRIPS
STEM	CANNONDALE C4, 1.5", 31.8, 7 DEGREE
HEADSET	TANGE CUSTOM 1.5"
BRAKES	AVID ELIXIR 1, 180/160MM
BRAKE LEVERS	AVID ELIXIR 1
SADDLE	CANNONDALE STAGE 3
SEATPOST	CANNONDALE C3, 27.2 X 350 (M), 400MM (L,X)
SIZES	S, M, L, X, J
COLOR 1 (CODE)	JET BLACK, GLOSS (BLK)
COLOR 2 (CODE)	N/A

TRAIL SL 3	
PRODUCT CODE	C13FS3
FRAME	TRAIL SL, OPTIMIZED 6061 ALLOY, SAVE, 1.5" HEADTUBE
FORK	ROCKSHOX XC 30 TK, COIL, 100MM, LOCKOUT, 1.5"
REAR SHOCK	N/A
RIMS	MADDUX DC3.0 DOUBLE WALL W/EYELET, 28 HOLE FRONT, 32 HOLE REAR
HUBS	CANNONDALE C4 FRONT AND REAR
SPOKES	STAINLESS STEEL, 15G BLACK
TIRES	SCHWALBE RAPID ROB, 26X2.1
PEDALS	FPD PLATFORM
CRANKS	SHIMANO FC-M430-8, OCTALINK, 44/32/22
BOTTOM BRACKET	SHIMANO BB-ES25, OCTALINK
CHAIN	SHIMANO HG53
REAR COGS	SUNRACE M96, 11-34, 9-SPEED
FRONT DERAILLEUR	SHIMANO ACERA, 31.8 CLAMP
REAR DERAILLEUR	SHIMANO DEORE, SHADOW DESIGN, 9-SPEED
SHIFTERS	SHIMANO ALIVIO, W/GEAR DISPLAY
HANDLEBAR	CANNONDALE C3, 680X20, 6061 DOUBLE-BUTTED ALLOY
GRIPS	CANNONDALE LOCKING GRIPS
STEM	CANNONDALE C4, 1.5", 31.8, 7 DEGREE
HEADSET	TANGE CUSTOM 1.5"
BRAKES	SHIMANO BR-M446, 160/160MM
BRAKE LEVERS	SHIMANO BR-M446
SADDLE	CANNONDALE STAGE 3
SEATPOST	CANNONDALE C3, 27.2X350MM (S,M) 400MM (L,X)
SIZES	S, M, L, X
COLOR (CODE)	JET BLACK, MATTE (BBQ)

ROAD SPECIFICATIONS

SUPERSIX EVO, BLACK EDITION	
PRODUCT CODE	C13RSEBD
FRAME	SUPERSIX EVO, BALLISTIC NANO CARBON, SPEED SAVE, PRESSFIT BB30
FORK	SUPERSIX EVO, SPEED SAVE, BALLISTIC NANO CARBON, 1-1/8" TO 1-1/4" STEERER
RIMS	ENVE ROAD 25MM 20H FRONT, 24H REAR
HUBS	DT SWISS 240, 20H FRONT, 24H REAR, 11 SPEED
SPOKES	DT SWISS AEROLITE
TIRES	SCHWALBE ULTREMO LIGHT TUBULAR 22MM
PEDALS	N/A
CRANKS	CANNONDALE HOLLOWGRAM SISL2, W/ OPI SPIDERING, 11 SPEED, 53-39 (COMPACT 50/34 INCLUDED)
BOTTOM BRACKET	CANNONDALE ALUMINUM PF30 BB CUP, FSA CERAMIC BB30 BEARING
CHAIN	SHIMANO DURA ACE 9000
REAR COGS	SHIMANO DURA ACE 9000, 11-25, 11-SPEED
FRONT DERAILLEUR	SHIMANO DURA ACE 9000
REAR DERAILLEUR	SHIMANO DURA ACE 9000
SHIFTERS	SHIMANO DURA ACE 9000
HANDLEBAR	ENVE CARBON ROAD COMPACT 31.8MM
GRIPS	FI'ZIK BAR TAPE
STEM	ENVE CARBON ROAD, 31.8, 6 DEG
HEADSET	SUPERSIX EVO SL, 1-1/4" LOWER BEARING, 15MM CARBON TOP COVER (W/ 5MM ALLOY HIDDEN TOP COVER)
BRAKES	SHIMANO DURA ACE 9000
BRAKE LEVERS	SHIMANO DURA ACE 9000
SADDLE	FI'ZIK ANTARES 00, WING FLEX, CARBON RAILS
SEATPOST	ENVE CARBON ROAD 27.2X350MM
SIZES	48, 50, 52, 54, 56, 58, 60, 63CM
COLOR (CODE)	JET BLACK W/ 40 BLUE, MATTE (BLE)
EXTRAS	INCLUDES BOTH STANDARD 53/39 AND COMPACT 50/34 SPIDERING CHAINRING SETS.

TRAIL SL 29"ER 4	
PRODUCT CODE	C13FS294
FRAME	TRAIL SL 29"ER, OPTIMIZED 6061 ALLOY, SAVE, 1.5" HEADTUBE
FORK	SR SUNTOUR XCR-LO-29, 80MM, LOCKOUT, 1.5" ALLOY STEERER
REAR SHOCK	N/A
RIMS	MADDUX DC3.0 29"ER, DOUBLE WALL W/EYELET, 32 HOLE
HUBS	CANNONDALE C4 FRONT AND REAR
SPOKES	STAINLESS STEEL, 15G BLACK
TIRES	WTB NINELINE, 29X2.0"
PEDALS	FPD PLATFORM
CRANKS	SHIMANO FC-M391-8, 44/32/22
BOTTOM BRACKET	SHIMANO BB-ES25, OCTALINK
CHAIN	SHIMANO HG53
REAR COGS	SUNRACE M96, 11-34, 9-SPEED
FRONT DERAILLEUR	SHIMANO ACERA, 31.8 CLAMP
REAR DERAILLEUR	SHIMANO ALIVIO
SHIFTERS	SHIMANO ACERA W/GEAR DISPLAY
HANDLEBAR	CANNONDALE C3, 680X20, 6061 DOUBLE-BUTTED ALLOY
GRIPS	CANNONDALE DUAL-DENSITY GRIP
STEM	CANNONDALE C4, 1.5", 31.8, 7 DEGREE
HEADSET	TANGE CUSTOM 1.5"
BRAKES	CANNONDALE HELIX 6 HYDRAULIC DISC, 180/160MM
BRAKE LEVERS	CANNONDALE HELIX 6 HYDRAULIC DISC
SADDLE	CANNONDALE STAGE 3
SEATPOST	CANNONDALE C3, 31.6 X 350 (M), 400MM (L,X)
SIZES	S, M, L, X, J
COLOR 1 (CODE)	JET BLACK W/GREEN ACCENTS, GLOSS (BLK)
COLOR 2 (CODE)	MAGNESIUM WHITE, GLOSS (WHT)

TRAIL SL 4	
PRODUCT CODE	C13FS4
FRAME	TRAIL SL, OPTIMIZED 6061 ALLOY, SAVE, 1.5" HEADTUBE
FORK	SR SUNTOUR XCR-LO, COIL, 100MM, LOCKOUT, 1-1/8"
REAR SHOCK	N/A
RIMS	MADDUX DC3.0 DOUBLE WALL W/EYELET, 28 HOLE FRONT, 32 HOLE REAR
HUBS	CANNONDALE C4 FRONT AND REAR
SPOKES	STAINLESS STEEL, 15G BLACK
TIRES	SCHWALBE RAPID ROB, 26X2.1
PEDALS	FPD PLATFORM
CRANKS	SHIMANO FC-M391-8, OCTALINK, 44/32/22
BOTTOM BRACKET	SHIMANO BB-ES25, OCTALINK
CHAIN	SHIMANO HG53
REAR COGS	SUNRACE M96, 11-34, 9-SPEED
FRONT DERAILLEUR	SHIMANO ALTUS, 31.8 CLAMP
REAR DERAILLEUR	SHIMANO ALIVIO, 9-SPEED
SHIFTERS	SHIMANO ACERA, W/GEAR DISPLAY
HANDLEBAR	CANNONDALE C3, 680X20, 6061 DOUBLE-BUTTED ALLOY
GRIPS	CANNONDALE DUAL-DENSITY GRIP
STEM	CANNONDALE C4, 1-1/8", 31.8, 7 DEGREE
HEADSET	TANGE REDUCER 1.5 - 1-1/8"
BRAKES	CANNONDALE HELIX 6 HYDRAULIC DISC, 160/160MM
BRAKE LEVERS	CANNONDALE HELIX 6
SADDLE	CANNONDALE STAGE 3
SEATPOST	CANNONDALE C3, 27.2X350MM (S,M) 400MM (L,X)
SIZES	S, M, L, X
COLOR (CODE)	JET BLACK, GLOSS (BLK)

SUPERSIX EVO HI-MOD DURA ACE D12	
PRODUCT CODE	C13RSEID
FRAME	SUPERSIX EVO, BALLISTIC HI-MOD CARBON, D12 SPECIFIC, SPEED SAVE, PRESSFIT BB30
FORK	SUPERSIX EVO, SPEED SAVE, BALLISTIC HI-MOD FULL CARBON, 1-1/8" TO 1-1/4" STEERER
RIMS	MAVIC KSYRIUM SLR WTS
HUBS	MAVIC KSYRIUM SLR
SPOKES	MAVIC KSYRIUM SLR
TIRES	MAVIC KYSION, GRIPLINK FRONT AND POWERLINK REAR, 700X23C, FOLDING
PEDALS	N/A
CRANKS	CANNONDALE HOLLOWGRAM SISL2, W/ OPI SPIDERING, 11 SPEED, 53-39 (COMPACT 50/34 INCLUDED)
BOTTOM BRACKET	CANNONDALE ALUMINUM PF30 BB CUP, FSA CERAMIC BB30 BEARING
CHAIN	SHIMANO DURA ACE 9000
REAR COGS	SHIMANO DURA ACE 9000, 11-25, 11-SPEED
FRONT DERAILLEUR	SHIMANO DURA ACE D12 9070
REAR DERAILLEUR	SHIMANO DURA ACE D12 9070
SHIFTERS	SHIMANO DURA ACE D12 9070
HANDLEBAR	FSA K-FORCE CARBON COMPACT
GRIPS	FI'ZIK BAR TAPE
STEM	FSA OS-99 CSI
HEADSET	SUPERSIX EVO, 1-1/4" LOWER BEARING, 25MM CARBON TOP COVER (W/ 5MM ALLOY HIDDEN TOP COVER)
BRAKES	SHIMANO DURA ACE 9000
BRAKE LEVERS	SHIMANO D12 9070
SADDLE	FI'ZIK ANTARES, KIJUM RAILS
SEATPOST	FSA K-FORCE CARBON, 27.2X350MM
SIZES	48, 50, 52, 54, 56, 58, 60, 63CM
COLOR (CODE)	EXPOSED CARBON W/ CHARCOAL GRAY AND RACE RED ACCENTS, MATTE (CRB)
EXTRAS	INCLUDES BOTH STANDARD 53/39 AND COMPACT 50/34 SPIDERING CHAINRING SETS.

TRAIL SL 1	
PRODUCT CODE	C13FS1
FRAME	TRAIL SL, OPTIMIZED 6061 ALLOY, SAVE, 1.5" HEADTUBE
FORK	ROCKSHOX RECON GOLD TK 100MM, SOLO AIR, LOCKOUT, REBOUND, 1.5"
REAR SHOCK	N/A
RIMS	MADDUX DC3.0 DOUBLE WALL W/EYELET, 32 HOLE
HUBS	SHIMANO HB-RM66 FRONT, FH-RM66 REAR, CENTER LOCK
SPOKES	STAINLESS STEEL, 15G BLACK
TIRES	SCHWALBE RAPID ROB, 26X2.1
PEDALS	FPD PLATFORM
CRANKS	FSA COMET, 42/32/24
BOTTOM BRACKET	FSA
CHAIN	FSA CN910
REAR COGS	SHIMANO HG62-10, 11-36, 10-SPEED
FRONT DERAILLEUR	SHIMANO DEORE, 31.8 CLAMP
REAR DERAILLEUR	SHIMANO XT, SHADOW DESIGN, 10-SPEED
SHIFTERS	SHIMANO DEORE W/GEAR DISPLAY
HANDLEBAR	CANNONDALE C3, 680X20, 6061 DOUBLE-BUTTED ALLOY
GRIPS	CANNONDALE DUAL-DENSITY GRIP
STEM	CANNONDALE C4, 1.5", 31.8, 7 DEGREE
HEADSET	TANGE CUSTOM 1.5"
BRAKES	SHIMANO BR-M505, 160/160MM
BRAKE LEVERS	SHIMANO BR-M505
SADDLE	CANNONDALE STAGE 3
SEATPOST	CANNONDALE C3, 27.2X350MM (S,M) 400MM (L,X)
SIZES	S, M, L, X
COLOR 1 (CODE)	JET BLACK, GLOSS (BLK)
COLOR 2 (CODE)	N/A

TRAIL SL 5	
PRODUCT CODE	C13FS5
FRAME	TRAIL SL, OPTIMIZED 6061 ALLOY, SAVE, 1.5" HEADTUBE
FORK	SR SUNTOUR XCM-HLO, COIL, 100MM, LOCKOUT, 1-1/8"
REAR SHOCK	N/A
RIMS	MADDUX DC3.0 DOUBLE WALL W/EYELET, 28 HOLE FRONT, 32 HOLE REAR
HUBS	CANNONDALE C4 FRONT AND REAR
SPOKES	STAINLESS STEEL, 15G BLACK
TIRES	SCHWALBE RAPID ROB, 26X2.1
PEDALS	FPD PLATFORM
CRANKS	SHIMANO, FC-M311, 42/32/22
BOTTOM BRACKET	TANGE SEIKI LN-3912
CHAIN	SHIMANO HG-40
REAR COGS	SHIMANO HG31-8, 11-32, 8-SPEED
FRONT DERAILLEUR	SHIMANO ALTUS, 31.8 CLAMP
REAR DERAILLEUR	SHIMANO ACERA, 8-SPEED
SHIFTERS	SHIMANO ALTUS, W/GEAR DISPLAY
HANDLEBAR	CANNONDALE C3, 680X20, 6061 DOUBLE-BUTTED ALLOY
GRIPS	CANNONDALE DUAL-DENSITY GRIP
STEM	CANNONDALE C4, 1-1/8", 31.8, 7 DEGREE
HEADSET	TANGE REDUCER 1.5 - 1-1/8"
BRAKES	CANNONDALE HELIX 6 HYDRAULIC DISC, 160/160MM
BRAKE LEVERS	CANNONDALE HELIX 6
SADDLE	CANNONDALE STAGE 3
SEATPOST	CANNONDALE C3, 27.2X350MM (S,M) 400MM (L,X)
SIZES	S, M, L, X
COLOR (CODE)	JET BLACK, GLOSS (BLK)

SUPERSIX EVO HI-MOD TEAM	
PRODUCT CODE	C13RSEOD
FRAME	SUPERSIX EVO, BALLISTIC HI-MOD CARBON, SPEED SAVE, PRESSFIT BB30
FORK	SUPERSIX EVO, SPEED SAVE, BALLISTIC HI-MOD FULL CARBON, 1-1/8" TO 1-1/4" STEERER
RIMS	MAVIC COSMIC CARBONE SLR WTS
HUBS	MAVIC COSMIC CARBONE SLR
SPOKES	MAVIC COSMIC CARBONE SLR
TIRES	MAVIC KYSION, GRIPLINK FRONT AND POWERLINK REAR, 700X23C, FOLDING
PEDALS	N/A
CRANKS	CANNONDALE HOLLOWGRAM SISL2, W/ OPI SPIDERING, 10 SPEED, 53-39 (COMPACT 50/34 INCLUDED)
BOTTOM BRACKET	CANNONDALE ALUMINUM PF30 BB CUP, FSA CERAMIC BB30 BEARING
CHAIN	SHIMANO DURA ACE 9000
REAR COGS	SRAM PC-1091R, 10-SPEED
FRONT DERAILLEUR	SRAM RED, 11-26, 10-SPEED
REAR DERAILLEUR	SRAM RED, BRAZE ON
SHIFTERS	SRAM RED
HANDLEBAR	SRAM RED DOUBLETAP
GRIPS	FSA K-FORCE CARBON NANO
STEM	FI'ZIK BAR TAPE
HEADSET	FSA K-FORCE CARBON, 31.8, 6 DEG
BRAKES	SUPERSIX EVO, 1-1/4" LOWER BEARING, 25MM CARBON TOP COVER (W/ 5MM ALLOY HIDDEN TOP COVER)
BRAKE LEVERS	SRAM RED
SADDLE	SRAM RED
SEATPOST	FI'ZIK ANTARES, BRAIDED CARBON RAILS
SIZES	FSA K-FORCE CARBON, 27.2X350MM
COLOR (CODE)	48, 50, 52, 54, 56, 58, 60, 63CM
EXTRAS	LIQUIGAS TEAM REPLICA, GLOSS (LIQ)
EXTRAS	INCLUDES BOTH STANDARD 53/39 AND COMPACT 50/34 SPIDERING CHAINRING SETS.

TRAIL SL 2	
PRODUCT CODE	C13FS2
FRAME	TRAIL SL, OPTIMIZED 6061 ALLOY, SAVE, 1.5" HEADTUBE
FORK	ROCKSHOX RECON SILVER TK 100MM, SOLO AIR, LOCKOUT, REBOUND, 1.5"
REAR SHOCK	N/A
RIMS	MADDUX DC3.0 DOUBLE WALL W/EYELET, 28 HOLE FRONT, 32 HOLE REAR
HUBS	FORMULA DC20 FRONT, DC22 REAR
SPOKES	STAINLESS STEEL, 15G BLACK
TIRES	SCHWALBE RAPID ROB, 26X2.1
PEDALS	FPD PLATFORM
CRANKS	SHIMANO M522, OCTALINK, 42/32/24
BOTTOM BRACKET	SHIMANO BB-ES25, OCTALINK
CHAIN	KMC X10
REAR COGS	SHIMANO HG-62, 11-36, 10-SPEED
FRONT DERAILLEUR	SHIMANO DEORE, 31.8 CLAMP
REAR DERAILLEUR	SHIMANO SLX, 10-SPEED
SHIFTERS	SHIMANO DEORE W/GEAR DISPLAY
HANDLEBAR	CANNONDALE C3, 680X20, 6061 DOUBLE-BUTTED ALLOY
GRIPS	CANNONDALE LOCKING GRIPS
STEM	CANNONDALE C4, 1.5", 31.8, 7 DEGREE
HEADSET	TANGE CUSTOM 1.5"
BRAKES	AVID ELIXIR 1, 160/160MM
BRAKE LEVERS	AVID ELIXIR 1
SADDLE	CANNONDALE STAGE 3
SEATPOST	CANNONDALE C3, 27.2X350MM (S,M) 400MM (L,X)
SIZES	S, M, L, X
COLOR 1 (CODE)	MAGNESIUM WHITE, GLOSS (WHT)
COLOR 2 (CODE)	N/A

SUPERSIX EVO HI-MOD DURA ACE	
PRODUCT CODE	C13RSEID
FRAME	SUPERSIX EVO, BALLISTIC HI-MOD CARBON, SPEED SAVE, PRESSFIT BB30
FORK	SUPERSIX EVO, SPEED SAVE, BALLISTIC HI-MOD FULL CARBON, 1-1/8" TO 1-1/4" STEERER
RIMS	MAVIC KSYRIUM SLR WTS
HUBS	MAVIC KSYRIUM SLR
SPOKES	MAVIC KSYRIUM SLR
TIRES	MAVIC KYSION, GRIPLINK FRONT AND POWERLINK REAR, 700X23C, FOLDING
PEDALS	N/A
CRANKS	CANNONDALE HOLLOWGRAM SISL2, W/ OPI SPIDERING, 11 SPEED, 53-39 (COMPACT 50/34 INCLUDED)
BOTTOM BRACKET	CANNONDALE ALUMINUM PF30 BB CUP, FSA CERAMIC BB30 BEARING
CHAIN	SHIMANO DURA ACE 9000
REAR COGS	SHIMANO DURA ACE 9000, 11-25, 11-SPEED
FRONT DERAILLEUR	SHIMANO DURA ACE 9000
REAR DERAILLEUR	SHIMANO DURA ACE 9000
SHIFTERS	SHIMANO DURA ACE 9000
HANDLEBAR	FSA K-FORCE CARBON COMPACT
GRIPS	FI'ZIK BAR TAPE
STEM	FSA OS-99 CSI
HEADSET	

ROAD SPECIFICATIONS

SUPERSIX EVO HI-MOD RED, RACING EDITION

PRODUCT CODE	C13R5ERC
FRAME	SUPERSIX EVO, BALLISTEC HI-MOD CARBON, SPEED SAVE, PRESSFIT BB30
FORK	SUPERSIX EVO, SPEED SAVE, BALLISTEC HI-MOD FULL CARBON, 1-1/8" TO 1-1/4" STEERER
RIMS	VISION TC24, CARBON RIM, 20/24H, TUBULAR
HUBS	VISION 20H FRONT, 24H REAR
SPOKES	SAPIM
TIRES	SCHWALBE ULTREMO HT TUBULAR 22MM
PEDALS	N/A
CRANKS	CANNONDALE HOLLOWGRAM SISL2, FSA CHAINRINGS, 53/39
BOTTOM BRACKET	CANNONDALE ALUMINIUM PF30 BB CUP, FSA BB30 BEARING
CHAIN	KMC X10SL, 10-SPEED
REAR COGS	SRAM PG-1070, 12-26, 10-SPEED
FRONT DERAILLEUR	SRAM RED, BRAZE ON
REAR DERAILLEUR	SRAM RED
SHIFTERS	SRAM RED DOUBLETAP
HANDLEBAR	CANNONDALE C2 CLASSIC, SHALLOW DROP
GRIPS	CANNONDALE BAR TAPE W/GEL, 2.5MM
STEM	CANNONDALE C1 31.8MM 6 DEG.
HEADSET	SUPERSIX EVO, 1-1/4" LOWER BEARING, 25MM CARBON TOP COVER (W/ 5MM ALLOY HIDDEN TOP COVER)
BRAKES	NEW SRAM RED
BRAKE LEVERS	NEW SRAM RED
SADDLE	PROLOGO NAGO EVO T1.4 RAIL
SEATPOST	CANNONDALE C1, LIGHTWEIGHT ALLOY 27.2X250MM
SIZES	48, 50, 52, 54, 56, 58, 60, 63CM
COLOR 1 (CODE)	MARINER BLUE W/ RACE RED AND 40 BLUE ACCENTS, GLOSS (BLU)
COLOR 2 (CODE)	EXPOSED CARBON, GLOSS (BLK)

SUPERSIX 5 105

PRODUCT CODE	C13RSS5C/
FRAME	SUPERSIX, FULL CARBON, BB30
FORK	SUPERSIX, FULL CARBON, 1-1/8" TO 1.5" TAPERED STEERER, ALLOY DROPOUTS
RIMS	SHIMANO RS-10
HUBS	SHIMANO RS-10
SPOKES	SHIMANO RS-10
TIRES	SCHWALBE LUGANO, 700X23C, FOLDING
PEDALS	N/A
CRANKS	FSA GOSSAMER PRO, BB30, 50/34 OR 50/39/30
BOTTOM BRACKET	FSA BB30
CHAIN	SHIMANO 105 5700
REAR COGS	SHIMANO 105 5700, 12-27, 10-SPEED
FRONT DERAILLEUR	SHIMANO 105 5700
REAR DERAILLEUR	SHIMANO 105 5700
SHIFTERS	SHIMANO 105 5700
HANDLEBAR	CANNONDALE C3 COMPACT
GRIPS	CANNONDALE BAR TAPE W/GEL, 2.5MM
STEM	CANNONDALE C3, 31.8MM, 6 DEG.
HEADSET	SUPERSIX, 1.5 LOWER BEARING, 30MM TOP CAP, W/5MM HIDDEN ALLOY TOP COVER
BRAKES	SHIMANO 105 5700
BRAKE LEVERS	SHIMANO 105 5700
SADDLE	PROLOGO SCRATCH PRO T2.0
SEATPOST	CANNONDALE C3 ALLOY, 31.6MMX300MM
SIZES	48, 50, 52, 54, 56, 58, 60, 63CM
COLOR 1 (CODE)	MAGNESIUM WHITE W/BERZERKER GREEN AND NU TEAM BLUE, GLOSS (REP)
COLOR 2 (CODE)	JET BLACK W/ CHARCOAL GRAY AND FINE SILVER ACCENTS, MATTE (BBQ)

CAAD8 5 105

PRODUCT CODE	C13RA85C/T
FRAME	CAAD8, OPTIMIZED 6061 ALLOY, SAVE, BB30
FORK	CANNONDALE ULTRA, CARBON BLADES, 1-1/8"
RIMS	MADDUX RS 3.0 SPEED, 32 HOLE
HUBS	FORMULA, RB-51 FRONT, RB-52 REAR
SPOKES	STAINLESS STEEL, 15G
TIRES	SCHWALBE LUGANO, 700X23C
PEDALS	WELLGO
CRANKS	FSA GOSSAMER, BB30, 50/34 OR 50/39/30
BOTTOM BRACKET	FSA BB30
CHAIN	KMC X10, 10-SPEED
REAR COGS	SHIMANO TIAGRA 4600, 12-28, 10-SPEED
FRONT DERAILLEUR	SHIMANO 105 5700, 31.8MM CLAMP
REAR DERAILLEUR	SHIMANO 105 5700
SHIFTERS	SHIMANO 105 5700
HANDLEBAR	CANNONDALE C3 COMPACT
GRIPS	CANNONDALE SUEDE BAR TAPE W/GEL, 2.5MM
STEM	CANNONDALE C3, 31.8MM, 6 DEG.
HEADSET	TANGE SEIKI INTEGRATED, 25MM TOP CAP
BRAKES	TEKTRO R540, DUAL PIVOT, CARTRIDGE PAD
BRAKE LEVERS	SHIMANO 105 5700
SADDLE	CANNONDALE STAGE ERGO W/ CRMO RAILS
SEATPOST	CANNONDALE C3, ALLOY, 27.2X300MM
SIZES	48, 51, 54, 56, 58, 61CM
COLOR 1 (CODE)	BRUSHED ALUMINUM, GLOSS (RAW)
COLOR 2 (CODE)	JET BLACK, MATTE (BBQ)

SUPERSIX EVO ULTEGRA DI2

PRODUCT CODE	C13RSSID
FRAME	SUPERSIX EVO, BALLISTEC CARBON, DI2 SPECIFIC, SPEED SAVE, PRESSFIT BB30
FORK	SUPERSIX EVO, SPEED SAVE, BALLISTEC CARBON, 1-1/8" TO 1-1/4" STEERER
RIMS	SHIMANO ULTEGRA 6700
HUBS	SHIMANO ULTEGRA 6700
SPOKES	SHIMANO ULTEGRA 6700
TIRES	SCHWALBE ULTREMO TUBELESS 700X23C
PEDALS	N/A
CRANKS	CANNONDALE HOLLOWGRAM SI, FSA CHAINRINGS, 53-39
BOTTOM BRACKET	SRAM PRESSFIT BB30
CHAIN	SHIMANO ULTEGRA 6700
REAR COGS	SHIMANO ULTEGRA 6700, 12-25, 10-SPEED
FRONT DERAILLEUR	SHIMANO ULTEGRA DI2 6770
REAR DERAILLEUR	SHIMANO ULTEGRA DI2 6770
SHIFTERS	SHIMANO ULTEGRA DI2 6770
HANDLEBAR	CANNONDALE C1 COMPACT
GRIPS	CANNONDALE BAR TAPE W/GEL, 2.5MM
STEM	CANNONDALE C1 31.8MM 6 DEG.
HEADSET	SUPERSIX EVO, 1-1/4" LOWER BEARING, 25MM CARBON TOP COVER (W/ 5MM ALLOY HIDDEN TOP COVER)
BRAKES	SHIMANO ULTEGRA 6700
BRAKE LEVERS	SHIMANO ULTEGRA DI2
SADDLE	FI'ZIK ANTARES, MANGANESE RAIL
SEATPOST	CANNONDALE C1, LIGHTWEIGHT ALLOY 27.2X250MM
SIZES	48, 50, 52, 54, 56, 58, 60, 63CM
COLOR 1 (CODE)	MAGNESIUM WHITE W/ JET BLACK AND ULTRA BLUE ACCENTS, GLOSS (WHT)
COLOR 2 (CODE)	EXPOSED CARBON, GLOSS (BLK)

CAAD10, BLACK EDITION

PRODUCT CODE	C13RAXIC
FRAME	CAAD10, DI2 SPECIFIC, SMARTFORMED 6069 ALLOY, SPEED SAVE, BB30
FORK	CAAD10, SPEED SAVE FULL CARBON, 1-1/8" TO 1-1/4" TAPERED STEERER
RIMS	SHIMANO ULTEGRA 6700
HUBS	SHIMANO ULTEGRA 6700
SPOKES	SHIMANO ULTEGRA 6700
TIRES	SCHWALBE DURANO S, 700X23C, FOLDING
PEDALS	N/A
CRANKS	FSA SL-K LIGHT CARBON BB30, 50/34
BOTTOM BRACKET	FSA BB30
CHAIN	SHIMANO ULTEGRA 6700
REAR COGS	SHIMANO ULTEGRA 6700, 12-25, 10-SPEED
FRONT DERAILLEUR	SHIMANO ULTEGRA DI2
REAR DERAILLEUR	SHIMANO ULTEGRA DI2
SHIFTERS	SHIMANO ULTEGRA DI2
HANDLEBAR	CANNONDALE C1 COMPACT
GRIPS	CANNONDALE BAR TAPE W/GEL, 2.5MM
STEM	CANNONDALE C1 31.8MM 6 DEG.
HEADSET	CAAD10, 1-1/4" LOWER BEARING, 25MM CARBON TOP CAP
BRAKES	SHIMANO ULTEGRA 6700
BRAKE LEVERS	SHIMANO ULTEGRA DI2
SADDLE	FI'ZIK ARIONE, MANGANESE RAIL
SEATPOST	CANNONDALE C1, LIGHTWEIGHT ALLOY 27.2X250MM
SIZES	48, 50, 52, 54, 56, 58, 60, 63CM
COLOR 1 (CODE)	BLACK ANODIZED, GOLD, MATTE (BLA)
COLOR 2 (CODE)	N/A

CAAD8 6 TIAGRA

PRODUCT CODE	C13RA86T
FRAME	CAAD8, OPTIMIZED 6061 ALLOY, SAVE, BB30
FORK	CANNONDALE ULTRA, CARBON BLADES, 1-1/8"
RIMS	MADDUX RS 3.0, 32 HOLE
HUBS	CANNONDALE C4
SPOKES	STAINLESS STEEL, 15G
TIRES	SCHWALBE LUGANO, 700X23C
PEDALS	WELLGO
CRANKS	FSA OMEGA BB30, 50/39/30
BOTTOM BRACKET	FSA BB30
CHAIN	KMC X10, 10-SPEED
REAR COGS	SHIMANO TIAGRA 4600, 12-28, 10-SPEED
FRONT DERAILLEUR	SHIMANO TIAGRA 4600, 31.8MM CLAMP
REAR DERAILLEUR	SHIMANO TIAGRA 4600
SHIFTERS	SHIMANO TIAGRA 4600
HANDLEBAR	CANNONDALE C4 COMPACT
GRIPS	CANNONDALE SUEDE BAR TAPE W/GEL, 2.5MM
STEM	CANNONDALE C4, 31.8MM, 6 DEG.
HEADSET	TANGE SEIKI INTEGRATED, 25MM TOP CAP
BRAKES	CANNONDALE C4, DUAL PIVOT, CARTRIDGE PAD
BRAKE LEVERS	SHIMANO TIAGRA 4600
SADDLE	CANNONDALE STAGE ERGO W/ STEEL RAILS
SEATPOST	CANNONDALE C4 ALLOY, 27.2MMX300MM
SIZES	48, 51, 54, 56, 58, 61CM
COLOR 1 (CODE)	MAGNESIUM WHITE, GLOSS (REP)
COLOR 2 (CODE)	N/A

SUPERSIX EVO 2 RED

PRODUCT CODE	C13RSS2D
FRAME	SUPERSIX EVO, BALLISTEC CARBON, SPEED SAVE, PRESSFIT BB30
FORK	SUPERSIX EVO, SPEED SAVE, BALLISTEC CARBON, 1-1/8" TO 1-1/4" STEERER
RIMS	MAVIC KSYRIUM EQUIPE S WTS
HUBS	MAVIC KSYRIUM EQUIPE S
SPOKES	MAVIC KSYRIUM EQUIPE S
TIRES	MAVIC KXSION PRO 700X23C
PEDALS	N/A
CRANKS	SRAM S901 CARBON, BB30, 53/39
BOTTOM BRACKET	SRAM PRESSFIT BB30
CHAIN	SRAM PC-1070
REAR COGS	SRAM PG-1070, 12-26, 10-SPEED
FRONT DERAILLEUR	NEW SRAM RED, BRAZE ON
REAR DERAILLEUR	NEW SRAM RED
SHIFTERS	NEW SRAM RED DOUBLETAP
HANDLEBAR	CANNONDALE C2 COMPACT
GRIPS	CANNONDALE BAR TAPE W/GEL, 2.5MM
STEM	CANNONDALE C1 31.8MM 6 DEG.
HEADSET	SUPERSIX EVO, 1-1/4" LOWER BEARING, 25MM CARBON TOP COVER (W/ 5MM ALLOY HIDDEN TOP COVER)
BRAKES	NEW SRAM RED
BRAKE LEVERS	NEW SRAM RED
SADDLE	FI'ZIK ANTARES, MANGANESE RAIL
SEATPOST	CANNONDALE C1, LIGHTWEIGHT ALLOY 27.2X250MM
SIZES	48, 50, 52, 54, 56, 58, 60, 63CM
COLOR 1 (CODE)	MAGNESIUM WHITE W/BERZERKER GREEN AND NU TEAM BLUE, GLOSS (REP)
COLOR 2 (CODE)	EXPOSED CARBON W/ CHARCOAL GRAY, MATTE (CRB)

CAAD10 3 ULTEGRA

PRODUCT CODE	C13RAX3C
FRAME	CAAD10, SMARTFORMED 6069 ALLOY, SPEED SAVE, BB30
FORK	CAAD10, SPEED SAVE FULL CARBON, 1-1/8" TO 1-1/4" TAPERED STEERER
RIMS	MAVIC AKSIUM WTS
HUBS	MAVIC AKSIUM WTS
SPOKES	MAVIC AKSIUM WTS
TIRES	MAVIC AKSION, 700X23C, FOLDING
PEDALS	N/A
CRANKS	FSA SL-K LIGHT CARBON BB30, 53/39
BOTTOM BRACKET	FSA BB30
CHAIN	SHIMANO ULTEGRA 6700
REAR COGS	SHIMANO ULTEGRA 6700, 12-25, 10-SPEED
FRONT DERAILLEUR	SHIMANO ULTEGRA DI2
REAR DERAILLEUR	SHIMANO ULTEGRA DI2
SHIFTERS	SHIMANO ULTEGRA DI2
HANDLEBAR	CANNONDALE C3 COMPACT
GRIPS	CANNONDALE BAR TAPE W/GEL, 2.5MM
STEM	CANNONDALE C2, 31.8, 6 DEG.
HEADSET	CAAD10, 1-1/4" LOWER BEARING, 25MM TOP CAP
BRAKES	SHIMANO ULTEGRA 6700
BRAKE LEVERS	SHIMANO ULTEGRA 6700
SADDLE	PROLOGO SCRATCH PRO T2.0
SEATPOST	CANNONDALE C2, UD CARBON, 27.2X300MM
SIZES	48, 50, 52, 54, 56, 58, 60, 63CM
COLOR 1 (CODE)	JET BLACK W/ MAGNESIUM WHITE AND CHARCOAL GRAY ACCENTS, MATTE (BBQ)
COLOR 2 (CODE)	BRUSHED ALUMINIUM W/ JET BLACK AND MAGNESIUM WHITE ACCENTS, GLOSS (RAW)

CAAD8 7 SORA

PRODUCT CODE	C13RA87T
FRAME	CAAD8, OPTIMIZED 6061 ALLOY, SAVE
FORK	CANNONDALE ULTRA, CARBON BLADES, 1-1/8"
RIMS	MADDUX RS 3.0, 32 HOLE
HUBS	CANNONDALE C4
SPOKES	STAINLESS STEEL, 15G
TIRES	SCHWALBE LUGANO, 700X23C
PEDALS	WELLGO
CRANKS	FSA VERO, 50/39/30
BOTTOM BRACKET	FSA
CHAIN	KMC 9-SPEED
REAR COGS	SRAM PG-950, 12-26, 9-SPEED
FRONT DERAILLEUR	SHIMANO SORA, 31.8MM CLAMP
REAR DERAILLEUR	SHIMANO SORA
SHIFTERS	SHIMANO SORA
HANDLEBAR	CANNONDALE C4 COMPACT
GRIPS	CANNONDALE SUEDE BAR TAPE W/GEL, 2.5MM
STEM	CANNONDALE C4, 31.8MM, 6 DEG.
HEADSET	TANGE SEIKI INTEGRATED, 25MM TOP CAP
BRAKES	CANNONDALE C4, DUAL PIVOT, CARTRIDGE PAD
BRAKE LEVERS	SHIMANO SORA
SADDLE	CANNONDALE STAGE ERGO W/ STEEL RAILS
SEATPOST	CANNONDALE C4 ALLOY, 27.2MMX300MM
SIZES	48, 51, 54, 56, 58, 61
COLOR 1 (CODE)	MAGNESIUM WHITE, GLOSS (WHT)
COLOR 2 (CODE)	N/A

SUPERSIX 3 ULTEGRA

PRODUCT CODE	C13RSS3C/D
FRAME	SUPERSIX, FULL CARBON, BB30
FORK	SUPERSIX, FULL CARBON, 1-1/8" TO 1.5" TAPERED STEERER, ALLOY DROPOUTS
RIMS	MAVIC AKSIUM WTS
HUBS	MAVIC AKSIUM WTS
SPOKES	MAVIC AKSIUM WTS
TIRES	MAVIC AKSION COMP, 700X23C, FOLDING
PEDALS	N/A
CRANKS	FSA SL-K LIGHT CARBON BB30, 53/39 OR 50/34
BOTTOM BRACKET	FSA BB30
CHAIN	SHIMANO ULTEGRA 6700
REAR COGS	SHIMANO ULTEGRA 6700, 12-25, 10-SPEED
FRONT DERAILLEUR	SHIMANO ULTEGRA 6700
REAR DERAILLEUR	SHIMANO ULTEGRA 6700
SHIFTERS	SHIMANO ULTEGRA 6700
HANDLEBAR	CANNONDALE C2 COMPACT
GRIPS	CANNONDALE BAR TAPE W/GEL, 2.5MM
STEM	CANNONDALE C2, 31.8, 6 DEG.
HEADSET	SUPERSIX, 1.5 LOWER BEARING, 30MM CARBON TOP CAP, W/5MM HIDDEN ALLOY TOP COVER
BRAKES	SHIMANO ULTEGRA 6700
BRAKE LEVERS	SHIMANO ULTEGRA 6700
SADDLE	FI'ZIK ARIONE, MANGANESE RAIL
SEATPOST	CANNONDALE C2, UD CARBON, 31.6X300MM
SIZES	48, 50, 52, 54, 56, 58, 60, 63CM
COLOR 1 (CODE)	MAGNESIUM WHITE W/ STEALTH GRAY AND BERSERKER GREEN ACCENTS, GLOSS (WHT)
COLOR 2 (CODE)	JET BLACK W/ CHARCOAL GRAY AND FINE SILVER ACCENTS, MATTE (BBQ)

CAAD10 5 105

PRODUCT CODE	C13RAX5C/T
FRAME	CAAD10, SMARTFORMED 6069 ALLOY, SPEED SAVE, BB30
FORK	CAAD10, SPEED SAVE FULL CARBON, 1-1/8" TO 1-1/4" TAPERED STEERER
RIMS	SHIMANO RS-10
HUBS	SHIMANO RS-10
SPOKES	SHIMANO RS-10
TIRES	SCHWALBE LUGANO, 700X23C, FOLDING
PEDALS	N/A
CRANKS	FSA GOSSAMER PRO, BB30, 50/34 OR 50/39/30
BOTTOM BRACKET	FSA BB30
CHAIN	SHIMANO 105 5700
REAR COGS	SHIMANO 105 5700, 12-27, 10-SPEED
FRONT DERAILLEUR	SHIMANO 105 5700
REAR DERAILLEUR	SHIMANO 105 5700
SHIFTERS	SHIMANO 105 5700
HANDLEBAR	CANNONDALE C3 COMPACT
GRIPS	CANNONDALE BAR TAPE W/GEL, 2.5MM
STEM	CANNONDALE C2, 31.8, 6 DEG.
HEADSET	CAAD10, 1-1/4" LOWER BEARING, 25MM TOP CAP
BRAKES	SHIMANO 105 5700
BRAKE LEVERS	SHIMANO 105 5700
SADDLE	PROLOGO, KAPPA EVO
SEATPOST	CANNONDALE C3, ALLOY, 27.2X300MM
SIZES	48, 50, 52, 54, 56, 58, 60, 63CM
COLOR 1 (CODE)	MAGNESIUM WHITE W/BERZERKER GREEN AND NU TEAM BLUE, GLOSS (REP)
COLOR 2 (CODE)	BRUSHED ALUMINIUM W/ JET BLACK AND MAGNESIUM WHITE ACCENTS, GLOSS (RAW)

ROAD SPECIFICATIONS

SYNAPSE HI-MOD, BLACK EDITION	
PRODUCT CODE	C13RCLIC
FRAME	SYNAPSE HI-MOD FULL CARBON, SAVE PLUS, BB30
FORK	SYNAPSE, HI-MOD FULL CARBON, SAVE PLUS, 1-1/8" STEERER
RIMS	MAVIC KSYRIUM SLS
HUBS	MAVIC KSYRIUM SLS
SPOKES	MAVIC KSYRIUM SLS
TIRES	MAVIC KYSION, GRIPLINK FRONT AND POWERLINK REAR, 700X25C, FOLDING
PEDALS	N/A
CRANKS	CANNONDALE HOLLOWGRAM SISL2, W/ OPI SPIDERING, 11 SPEED, 50-34
BOTTOM BRACKET	FSA BB30
CHAIN	SHIMANO DURA ACE 9000
REAR COGS	SHIMANO DURA ACE 9000, 11-28, 11-SPEED
FRONT DERAILLEUR	SHIMANO DURA ACE 9000
REAR DERAILLEUR	SHIMANO DURA ACE 9000
SHIFTERS	SHIMANO DURA ACE 9000
HANDLEBAR	FSA SL-K COMPACT,
GRIPS	CANNONDALE BAR TAPE W/GEL, 3.5MM
STEM	FSA OS-99 CSI, 31.8, 6 DEG
HEADSET	SYNAPSE SI, 25MM CARBON TOP CAP
BRAKES	SHIMANO DURA ACE 9000
BRAKE LEVERS	SHIMANO DURA ACE 9000
SADDLE	FI'ZIK ALIANTE MONOCOVER W/ KJUM RAILS
SEATPOST	FSA SL-K CARBON, 27.2X350MM
SIZES	48, 51, 54, 56, 58, 61CM
COLOR 1 (CODE)	NEARLY BLACK W/MAGNESIUM WHITE, MATTE (BLE)
COLOR 2 (CODE)	N/A

SYNAPSE CARBON 5 10S	
PRODUCT CODE	C13CSSC/T
FRAME	SYNAPSE, FULL CARBON, SAVE PLUS, BB30
FORK	SYNAPSE, FULL CARBON, SAVE PLUS, 1-1/8"
RIMS	SHIMANO RS-10
HUBS	SHIMANO RS-10
SPOKES	SHIMANO RS-10
TIRES	SCHWALBE LUGANO, 700X25C, FOLDING
PEDALS	N/A
CRANKS	FSA GOSSAMER PRO, BB30, 50/34 OR 50/39/30
BOTTOM BRACKET	FSA BB30
CHAIN	SHIMANO 10S 5700
REAR COGS	SHIMANO 10S 5700, 11-28, 10-SPEED
FRONT DERAILLEUR	SHIMANO 10S 5700
REAR DERAILLEUR	SHIMANO 10S 5700
SHIFTERS	SHIMANO 10S 5700
HANDLEBAR	CANNONDALE C3 COMPACT
GRIPS	CANNONDALE BAR TAPE W/GEL, 3.5MM
STEM	CANNONDALE C3, 31.8MM, 6 DEG.
HEADSET	SYNAPSE SI, 25MM TOP CAP
BRAKES	SHIMANO 10S 5700
BRAKE LEVERS	SHIMANO 10S 5700
SADDLE	PROLOGO, KAPPA EVO
SEATPOST	CANNONDALE C3 ALLOY, 27.2MMX300MM
SIZES	48, 51, 54, 56, 58, 61CM
COLOR 1 (CODE)	EXPOSED CARBON W/ STEALTH GRAY AND ULTRA BLUE ACCENTS, GLOSS (BLU)
COLOR 2 (CODE)	JET BLACK W/ MAGNESIUM WHITE AND CHARCOAL GRAY ACCENTS, MATTE (BBQ)

SLICE RS, BLACK EDITION	
PRODUCT CODE	C13RMS0D
FRAME	SLICE RS, FULL CARBON, AERO SAVE, PF30, NAERO-TEC
FORK	SLICE RS AERO, CARBON W/ INTEGRATED EXTERNAL STEERER, NAERO-TEC
RIMS	ZIPP 808 FIRECREST TUBULAR
HUBS	ZIPP 808 FIRECREST TUBULAR
SPOKES	ZIPP 808 FIRECREST TUBULAR
TIRES	SCHWALBE ULTREMO HT TUBULAR 700X22C
PEDALS	N/A
CRANKS	CANNONDALE HOLLOWGRAM SISL2, AERO SPIDER, 54/42
BOTTOM BRACKET	CANNONDALE ALUMINUM PF30 BB CUP, FSA CERAMIC BB30 BEARING
CHAIN	SRAM PC-1091R, 10-SPEED
REAR COGS	SRAM RED, 11-26, 10-SPEED
FRONT DERAILLEUR	SRAM RED
REAR DERAILLEUR	SRAM RED
SHIFTERS	SRAM RED
HANDLEBAR	VISION CARBON 31.8MM, VECTOR CARBON EXTENSIONS
GRIPS	FI'ZIK BAR TAPE
STEM	INTEGRATED, ADJUSTABLE 31.8MM
HEADSET	TANGE SEIKI INTEGRATED
BRAKES	CANNONDALE NAERO-TEC INTEGRATED MINI-V. CARBON ARMS
BRAKE LEVERS	SRAM RL990 CARBON
SADDLE	FI'ZIK ARIONE 00 TRIZ CARBON
SEATPOST	CANNONDALE SLICE RS CARBON NAERO -TEC
SIZES	50,52,54,56,58CM
COLOR (CODE)	NEARLY BLACK W/ BERSERKER GREEN, MATTE (BLE)

SYNAPSE HI-MOD RED	
PRODUCT CODE	C13RCL2C
FRAME	SYNAPSE HI-MOD FULL CARBON, SAVE PLUS, BB30
FORK	SYNAPSE, HI-MOD FULL CARBON, SAVE PLUS, 1-1/8" STEERER
RIMS	MAVIC KSYRIUM ELITE S WTS
HUBS	MAVIC KSYRIUM ELITE S WTS
SPOKES	MAVIC KSYRIUM ELITE S WTS
TIRES	MAVIC KYSION, GRIPLINK FRONT AND POWERLINK REAR, 700X25C, FOLDING
PEDALS	N/A
CRANKS	SRAM S951 CARBON, BB30, 50/34
BOTTOM BRACKET	SRAM BB30
CHAIN	SRAM PC-1070
REAR COGS	SRAM PG-1070, 11-28, 10-SPEED
FRONT DERAILLEUR	SRAM RED, BRAZE ON
REAR DERAILLEUR	SRAM RED
SHIFTERS	SRAM RED DOUBLETAP
HANDLEBAR	FSA PRO-WING COMPACT
GRIPS	CANNONDALE BAR TAPE W/GEL, 3.5MM
STEM	FSA SL-K, 31.8, 6 DEG
HEADSET	SYNAPSE SI, 25MM CARBON TOP CAP
BRAKES	SRAM RED
BRAKE LEVERS	SRAM RED
SADDLE	FI'ZIK ALIANTE DELTA, MG RAILS
SEATPOST	FSA SL-K CARBON, 27.2X350MM
SIZES	48, 51, 54, 56, 58, 61CM
COLOR 1 (CODE)	MAGNESIUM WHITE W/ BERSERKER GREEN, NU TEAM BLUE, GLOSS (WHT)
COLOR 2 (CODE)	EXPOSED CARBON W/ FINE SILVER, MAGNESIUM WHITE, MATTE (BBQ)

SYNAPSE CARBON 6 TIAGRA	
PRODUCT CODE	C13RCS6T
FRAME	SYNAPSE, FULL CARBON, SAVE PLUS, BB30
FORK	SYNAPSE, CARBON BLADES, SAVE, 1-1/8"
RIMS	SHIMANO R501
HUBS	SHIMANO R501
SPOKES	SHIMANO R501
TIRES	SCHWALBE LUGANO, 700X25C
PEDALS	N/A
CRANKS	FSA OMEGA, BB30, 50/39/30
BOTTOM BRACKET	FSA BB30
CHAIN	SHIMANO TIAGRA 4600, 10-SPEED
REAR COGS	SHIMANO TIAGRA 4600, 12-30, 10-SPEED
FRONT DERAILLEUR	SHIMANO TIAGRA 4600
REAR DERAILLEUR	SHIMANO TIAGRA 4600
SHIFTERS	SHIMANO TIAGRA 4600
HANDLEBAR	CANNONDALE C3 COMPACT
GRIPS	CANNONDALE BAR TAPE W/GEL, 3.5MM
STEM	CANNONDALE C3, 31.8MM, 6 DEG.
HEADSET	SYNAPSE SI, 25MM TOP CAP
BRAKES	SHIMANO TIAGRA 4600
BRAKE LEVERS	SHIMANO TIAGRA 4600
SADDLE	CANNONDALE STAGE ERGO W/ CRMO RAILS
SEATPOST	CANNONDALE C3 ALLOY, 27.2MMX300MM
SIZES	48, 51, 54, 56, 58, 61CM
COLOR 1 (CODE)	JET BLACK W/ BERSERKER GREEN AND MAGNESIUM WHITE ACCENTS, GLOSS (GRN)
COLOR 2 (CODE)	N/A

SLICE RS ULTEGRA D12	
PRODUCT CODE	C13RMS1D
FRAME	SLICE RS, FULL CARBON, AERO SAVE, PF30, NAERO-TEC
FORK	SLICE RS AERO, CARBON W/ INTEGRATED EXTERNAL STEERER, NAERO-TEC
RIMS	VISION TRIMAX T42
HUBS	VISION TRIMAX T42
SPOKES	VISION TRIMAX T42
TIRES	SCHWALBE ULTREMO ZX 700X23C
PEDALS	N/A
CRANKS	FSA TRIMAX CARBON RINGS, BB30
BOTTOM BRACKET	CANNONDALE ALUMINUM PF30 BB CUP, FSA BB30 BEARING
CHAIN	SHIMANO ULTEGRA 6700
REAR COGS	SHIMANO ULTEGRA 6700, 12-25, 10-SPEED
FRONT DERAILLEUR	SHIMANO ULTEGRA D12
REAR DERAILLEUR	SHIMANO ULTEGRA D12
SHIFTERS	SHIMANO ULTEGRA D12
HANDLEBAR	VISION 31.8MM, VECTOR CARBON EXTENSIONS
GRIPS	FI'ZIK BAR TAPE
STEM	INTEGRATED, ADJUSTABLE 31.8MM
HEADSET	TANGE SEIKI INTEGRATED
BRAKES	CANNONDALE NAERO-TEC INTEGRATED MINI-V
BRAKE LEVERS	TRP RL970 CARBON
SADDLE	FI'ZIK ARIONE TRIZ, W/ MG RAILS
SEATPOST	CANNONDALE SLICE RS CARBON NAERO -TEC
SIZES	50,52,54,56,58CM
COLOR (CODE)	MAGNESIUM WHITE W/ JET BLACK AND RACE RED, GLOSS (WHT)

SYNAPSE HI-MOD 3 ULTEGRA	
PRODUCT CODE	C13RCL3C/T
FRAME	SYNAPSE HI-MOD FULL CARBON, SAVE PLUS, BB30
FORK	SYNAPSE, HI-MOD FULL CARBON, SAVE PLUS, 1-1/8" STEERER
RIMS	MAVIC KSYRIUM EQUIPE S WTS
HUBS	MAVIC KSYRIUM EQUIPE S WTS
SPOKES	MAVIC KSYRIUM EQUIPE S WTS
TIRES	MAVIC WTS 700X25C
PEDALS	N/A
CRANKS	FSA SL-K LIGHT CARBON BB30, 50/34 OR 50/39/30
BOTTOM BRACKET	FSA BB30
CHAIN	SHIMANO ULTEGRA 6700
REAR COGS	SHIMANO ULTEGRA 6700, 11-28, 10-SPEED
FRONT DERAILLEUR	SHIMANO ULTEGRA 6700
REAR DERAILLEUR	SHIMANO ULTEGRA 6700
SHIFTERS	SHIMANO ULTEGRA 6700
HANDLEBAR	CANNONDALE C1 COMPACT
GRIPS	CANNONDALE BAR TAPE W/GEL, 3.5MM
STEM	CANNONDALE C1 31.8MM 6 DEG.
HEADSET	SYNAPSE SI, 25MM CARBON TOP CAP
BRAKES	SHIMANO ULTEGRA 6700
BRAKE LEVERS	SHIMANO ULTEGRA 6700
SADDLE	FI'ZIK ALIANTE DELTA, MG RAILS
SEATPOST	FSA SL-K CARBON, 27.2X350MM
SIZES	48, 51, 54, 56, 58, 61CM
COLOR 1 (CODE)	MAGNESIUM WHITE W/ JET BLACK AND ULTRA BLUE ACCENTS, GLOSS (BLU)
COLOR 2 (CODE)	EXPOSED CARBON W/ FINE SILVER, MAGNESIUM WHITE, MATTE (BBQ)

SYNAPSE 5 10S	
PRODUCT CODE	C13RASST
FRAME	SYNAPSE ALLOY, OPTIMIZED 6061 ALLOY, SAVE PLUS, BB30
FORK	SYNAPSE SAVE, CARBON BLADES, 1-1/8"
RIMS	SHIMANO RS10
HUBS	SHIMANO RS10
SPOKES	SHIMANO RS10
TIRES	SCHWALBE LUGANO, 700X25C
PEDALS	WELLGO PLATFORM
CRANKS	FSA GOSSAMER, BB30, 50/39/30
BOTTOM BRACKET	FSA BB30
CHAIN	FSA 10-SPEED
REAR COGS	SHIMANO TIAGRA 4600, 12-28, 10-SPEED
FRONT DERAILLEUR	SHIMANO 10S 5700, 34.9MM CLAMP
REAR DERAILLEUR	SHIMANO 10S 5700
SHIFTERS	SHIMANO 10S 5700
HANDLEBAR	CANNONDALE C3 COMPACT
GRIPS	CANNONDALE SUEDE BAR TAPE W/GEL, 3.5MM
STEM	CANNONDALE C3, 31.8, 6 DEG.
HEADSET	SYNAPSE SI, 25MM TOP CAP
BRAKES	SHIMANO BR-560, DUAL PIVOT, CARTRIDGE PAD, LONG REACH
BRAKE LEVERS	SHIMANO 10S 5700
SADDLE	CANNONDALE STAGE ERGO W/ CRMO RAILS
SEATPOST	CANNONDALE C3, CARBON WRAPPED, 27.2X300MM
SIZES	48, 51, 54, 56, 58, 61CM
COLOR 1 (CODE)	BRUSHED ALUMINUM, GLOSS (RAW)
COLOR 2 (CODE)	MAGNESIUM WHITE, GLOSS (WHT)

SLICE RS ULTEGRA	
PRODUCT CODE	C13RMS3D
FRAME	SLICE RS, FULL CARBON, AERO SAVE, PF30, NAERO-TEC
FORK	SLICE RS AERO, CARBON W/ INTEGRATED EXTERNAL STEERER, NAERO-TEC
RIMS	MAVIC COSMIC ELITE
HUBS	MAVIC COSMIC ELITE
SPOKES	MAVIC COSMIC ELITE
TIRES	SCHWALBE DURANO S, 700X23C, FOLDING
PEDALS	N/A
CRANKS	FSA TRIMAX ALLOY RINGS, BB30
BOTTOM BRACKET	CANNONDALE ALUMINUM PF30 BB CUP, FSA BB30 BEARING
CHAIN	SHIMANO ULTEGRA 6700
REAR COGS	SHIMANO 10S 5700, 12-25, 10-SPEED
FRONT DERAILLEUR	SHIMANO ULTEGRA 6700
REAR DERAILLEUR	SHIMANO ULTEGRA 6700
SHIFTERS	SHIMANO DURA-ACE, BAR-END
HANDLEBAR	VISION 31.8MM, VECTOR CARBON EXTENSIONS
GRIPS	FI'ZIK BAR TAPE
STEM	INTEGRATED, ADJUSTABLE 31.8MM
HEADSET	TANGE SEIKI INTEGRATED
BRAKES	CANNONDALE NAERO-TEC INTEGRATED MINI-V
BRAKE LEVERS	TRP RL970 CARBON
SADDLE	FI'ZIK ARIONE TRIZ, W/ MG RAILS
SEATPOST	CANNONDALE SLICE RS CARBON NAERO -TEC
SIZES	50,52,54,56,58CM
COLOR (CODE)	MAGNESIUM WHITE W/ JET BLACK AND RACE RED, GLOSS (WHT)

SYNAPSE CARBON 3 ULTEGRA	
PRODUCT CODE	C13RCS3CT
FRAME	SYNAPSE, FULL CARBON, SAVE PLUS, BB30
FORK	SYNAPSE, FULL CARBON, SAVE PLUS, 1-1/8"
RIMS	MAVIC AKSIUM WTS
HUBS	MAVIC AKSIUM WTS
SPOKES	MAVIC AKSIUM WTS
TIRES	MAVIC AKSION, 700X25C, FOLDING
PEDALS	N/A
CRANKS	FSA SL-K LIGHT CARBON BB30, 50/34 OR 50/39/30
BOTTOM BRACKET	FSA BB30
CHAIN	SHIMANO ULTEGRA 6700
REAR COGS	SHIMANO ULTEGRA 6700, 11-28, 10-SPEED
FRONT DERAILLEUR	SHIMANO ULTEGRA 6700
REAR DERAILLEUR	SHIMANO ULTEGRA 6700
SHIFTERS	SHIMANO ULTEGRA 6700
HANDLEBAR	CANNONDALE C2 COMPACT
GRIPS	CANNONDALE BAR TAPE W/GEL, 3.5MM
STEM	CANNONDALE C2, 31.8, 6 DEG.
HEADSET	SYNAPSE SI, 25MM TOP CAP
BRAKES	SHIMANO ULTEGRA 6700
BRAKE LEVERS	SHIMANO ULTEGRA 6700
SADDLE	FI'ZIK ALIANTE DELTA, MG RAILS
SEATPOST	CANNONDALE C2, UD CARBON, 27.2X300MM
SIZES	48, 51, 54, 56, 58, 61CM
COLOR 1 (CODE)	EXPOSED CARBON W/ 40 BLUE AND RACE RED ACCENTS, GLOSS (BLU)
COLOR 2 (CODE)	MAGNESIUM WHITE W/ JET BLACK, GLOSS (WHT)

SYNAPSE 6 TIAGRA	
PRODUCT CODE	C13RAS6T
FRAME	SYNAPSE ALLOY, OPTIMIZED 6061 ALLOY, SAVE PLUS, BB30
FORK	SYNAPSE SAVE, CARBON BLADES, 1-1/8"
RIMS	MADDUX RS 3.0, 32 HOLE
HUBS	CANNONDALE C4
SPOKES	STAINLESS STEEL, 15G
TIRES	SCHWALBE LUGANO, 700X25C
PEDALS	WELLGO PLATFORM
CRANKS	FSA OMEGA, BB30, 50/39/30
BOTTOM BRACKET	FSA BB30
CHAIN	KMC X10, 10-SPEED
REAR COGS	SHIMANO TIAGRA 4600, 12-28, 10-SPEED
FRONT DERAILLEUR	SHIMANO TIAGRA 4600, 34.9MM CLAMP
REAR DERAILLEUR	SHIMANO TIAGRA 4600
SHIFTERS	SHIMANO TIAGRA 4600
HANDLEBAR	CANNONDALE C4 COMPACT
GRIPS	CANNONDALE SUEDE BAR TAPE W/GEL, 3.5MM
STEM	CANNONDALE C4, 31.8, 6 DEG.
HEADSET	SYNAPSE SI, 25MM TOP CAP
BRAKES	SHIMANO BR-451, DUAL PIVOT, LONG REACH
BRAKE LEVERS	SHIMANO TIAGRA 4600
SADDLE	CANNONDALE STAGE ERGO W/ STEEL RAILS
SEATPOST	CANNONDALE C4, ALLOY, 27.2X300MM
SIZES	48, 51, 54, 56, 58, 61CM
COLOR 1 (CODE)	MAGNESIUM WHITE, GLOSS (WHT)
COLOR 2 (CODE)	JET BLACK, MATTE (BBQ)

SLICE HI-MOD RED D	
PRODUCT CODE	C13RM2D
FRAME	SLICE, HI-MOD CARBON, AERO SAVE, BB30
FORK	SLICE AERO, HI-MOD CARBON, 1-1/8"
RIMS	FULCRUM RACING 7
HUBS	FULCRUM RACING 7
SPOKES	FULCRUM RACING 7
TIRES	SCHWALBE DURANO S, 700X23C, FOLDING
PEDALS	N/A
CRANKS	CANNONDALE HOLLOWGRAM SI, FSA CHAINRINGS, 53-39T
BOTTOM BRACKET	FSA BB30
CHAIN	SRAM PC-1070</

ROAD SPECIFICATIONS

SLICE 3 ULTEGRA

PRODUCT CODE	C13RM3D
FRAME	SLICE, FULL CARBON, AERO SAVE, BB30
FORK	SLICE AERO, FULL CARBON, 1-1/8"
RIMS	FULCRUM RACING 7
HUBS	FULCRUM RACING 7
SPOKES	FULCRUM RACING 7
TIRES	SCHWALBE LUGANO, 700X23C, FOLDING
PEDALS	N/A
CRANKS	FSA GOSSAMER TT, BB30, 52,38
BOTTOM BRACKET	FSA BB30
CHAIN	SHIMANO 105 5700
REAR COGS	SHIMANO 105 5700, 12-27, 10-SPEED
FRONT DERAILLEUR	SHIMANO ULTEGRA 6700
REAR DERAILLEUR	SHIMANO ULTEGRA 6700
SHIFTERS	SHIMANO DURA-ACE, BAR-END
HANDLEBAR	CANNONDALE C3 BASE BAR, 31.8 W/ FSA TRI MAX TEAM CLIP ONS
GRIPS	CANNONDALE BAR TAPE W/GEL, 2.5MM
STEM	CANNONDALE C3, 31.8, 6 DEG.
HEADSET	SLICE, SI, 15MM TOP CAP
BRAKES	SHIMANO ULTEGRA 6700
BRAKE LEVERS	ALLOY AERO LEVERS
SADDLE	FI'ZIK ARIONE TRI2, W/ MG RAILS
SEATPOST	CANNONDALE SLICE CARBON AERO
SIZES	51, 54, 56, 58, 60CM
COLOR 1 (CODE)	MAGNESIUM WHITE W/ PROCESS CYAN, GLOSS (WHT)
COLOR 2 (CODE)	MAGNESIUM WHITE W/ RUBY RED (GLOSS) (WHT)

SLICE 105

PRODUCT CODE	C13RM5D
FRAME	SLICE, FULL CARBON, AERO SAVE, BB30
FORK	SLICE AERO, FULL CARBON, 1-1/8"
RIMS	SHIMANO RS-10
HUBS	SHIMANO RS-10
SPOKES	SHIMANO RS-10
TIRES	SCHWALBE LUGANO, 700X23C
PEDALS	N/A
CRANKS	FSA GOSSAMER PRO, BB30, 53/39
BOTTOM BRACKET	FSA BB30
CHAIN	SHIMANO TIAGRA 4600, 10-SPEED
REAR COGS	SHIMANO TIAGRA 4600, 12-28, 10-SPEED
FRONT DERAILLEUR	SHIMANO 105 5700
REAR DERAILLEUR	SHIMANO 105 5700
SHIFTERS	MICROSHIFT BAR-END
HANDLEBAR	CANNONDALE C3 BASE BAR, 31.8 W/ FSA TRI MAX TEAM CLIP ONS
GRIPS	CANNONDALE BAR TAPE W/GEL, 2.5MM
STEM	CANNONDALE C3, 31.8, 6 DEG.
HEADSET	SLICE, SI, 15MM TOP CAP
BRAKES	TEKTRO RS50
BRAKE LEVERS	ALLOY AERO LEVERS
SADDLE	CANNONDALE ERGO TRI
SEATPOST	CANNONDALE SLICE CARBON AERO
SIZES	51, 54, 56, 58, 60CM
COLOR 1 (CODE)	JET BLACK W/ CHARCOAL GRAY, MATTE (BBQ)
COLOR 2 (CODE)	INDIGO BLUE W/ MAGNESIUM WHITE (GLOSS) (BLU)

SUPERX HI-MOD DISC

PRODUCT CODE	C13XC0C
FRAME	SUPERX DISC, BALLISTEC HI-MOD CARBON, SPEED SAVE, BB30
FORK	SUPERX DISC, BALLISTEC HI-MOD FULL CARBON, 1-1/8" TO 1-1/4" STEERER
RIMS	STANS ALPHA 340 DISC, TUBELESS, 24H FRONT, 28H REAR
HUBS	STANS 3.30 TI
SPOKES	DT COMPETITION
TIRES	SCHWALBE RACING RALPH 700X33C
PEDALS	N/A
CRANKS	FSA SL-K LIGHT CARBON BB30, 46/36
BOTTOM BRACKET	FSA BB30
CHAIN	KMC X10SL, 10-SPEED
REAR COGS	SRAM PG-1070, 11-26, 10-SPEED
FRONT DERAILLEUR	SRAM RED, BRAZE ON
REAR DERAILLEUR	SRAM RED
SHIFTERS	SRAM RED DOUBLETAP
HANDLEBAR	CANNONDALE C1 COMPACT
GRIPS	CANNONDALE BAR TAPE W/GEL, 2.5MM
STEM	CANNONDALE C1 31.8MM 6 DEG.
HEADSET	SUPER X, 1-1/4" LOWER BEARING, 25MM CARBON TOP CAP
BRAKES	AVID BB7 ULTIMATE
BRAKE LEVERS	SRAM RED
SADDLE	FI'ZIK TUNDRA 2
SEATPOST	CANNONDALE C1, LIGHTWEIGHT ALLOY 27.2X250MM
SIZES	44,48,50,52,54,56,58CM
COLOR 1 (CODE)	JET BLACK W/ BERSERKER GREEN, GLOSS (GRN)
COLOR 2 (CODE)	PORCELAIN BLUE W/WHITE PEARL (GLOSS) (BLU)

SUPERX HI-MOD ULTEGRA D12

PRODUCT CODE	C13XC1C
FRAME	SUPERX, D12 SPECIFIC, BALLISTEC HI-MOD CARBON, SPEED SAVE, BB30
FORK	SUPERX, BALLISTEC HI-MOD FULL CARBON, 1-1/8" TO 1-1/4" STEERER
RIMS	SHIMANO ULTEGRA 6700 TUBELESS
HUBS	SHIMANO ULTEGRA 6700
SPOKES	SHIMANO ULTEGRA 6700
TIRES	SCHWALBE RACING RALPH 700X33C
PEDALS	N/A
CRANKS	FSA SL-K LIGHT CARBON BB30, 46/36
BOTTOM BRACKET	FSA BB30
CHAIN	SHIMANO ULTEGRA 6700
REAR COGS	SHIMANO ULTEGRA 6700, 12-25, 10-SPEED
FRONT DERAILLEUR	SHIMANO ULTEGRA D12
REAR DERAILLEUR	SHIMANO ULTEGRA D12
SHIFTERS	SHIMANO ULTEGRA D12
HANDLEBAR	CANNONDALE C2 COMPACT
GRIPS	CANNONDALE BAR TAPE W/GEL, 2.5MM
STEM	CANNONDALE C2, 31.8, 6 DEG.
HEADSET	CANNONDALE SUPERX, 1-1/8" TO 1-1/4", 15MM TOP CAP
BRAKES	TRP EURO-X ALLOY
BRAKE LEVERS	SHIMANO ULTEGRA D12
SADDLE	FI'ZIK TUNDRA 2
SEATPOST	CANNONDALE C2, UD CARBON, 27.2X300MM
SIZES	44,48,50,52,54,56,58CM
COLOR 1 (CODE)	JET BLACK W/ BERSERKER GREEN, GLOSS (GRN)
COLOR 2 (CODE)	MAGNESIUM WHITE W/JET BLACK, GREEN APPLE (GLOSS) (WHT)

SUPERX CARBON ULTEGRA

PRODUCT CODE	C13XC3C
FRAME	SUPERX, BALLISTEC CARBON, SPEED SAVE, BB30
FORK	SUPERX, BALLISTEC CARBON, 1-1/8" TO 1-1/4" STEERER
RIMS	MAVIC KSYRIUM EQUIPE
HUBS	MAVIC KSYRIUM EQUIPE
SPOKES	MAVIC KSYRIUM EQUIPE
TIRES	SCHWALBE RAPID ROB, 700X35C
PEDALS	N/A
CRANKS	FSA GOSSAMER PRO, BB30, 46/36
BOTTOM BRACKET	FSA BB30
CHAIN	SHIMANO ULTEGRA 6700
REAR COGS	SHIMANO ULTEGRA 6700, 12-25, 10-SPEED
FRONT DERAILLEUR	SHIMANO ULTEGRA 6700
REAR DERAILLEUR	SHIMANO ULTEGRA 6700
SHIFTERS	SHIMANO ULTEGRA 6700
HANDLEBAR	CANNONDALE C2 COMPACT
GRIPS	CANNONDALE BAR TAPE W/GEL, 2.5MM
STEM	CANNONDALE C2, 31.8, 6 DEG.
HEADSET	CANNONDALE SUPERX, 1-1/8" TO 1-1/4", 15MM TOP CAP
BRAKES	TRP EURO-X ALLOY
BRAKE LEVERS	SHIMANO ULTEGRA
SADDLE	FI'ZIK TUNDRA 2
SEATPOST	CANNONDALE C2, UD CARBON, 27.2X300MM
SIZES	44,48,50,52,54,56,58CM
COLOR (CODE)	MAGNESIUM WHITE W/ JET BLACK, GLOSS (WHT)

SUPERX CARBON RIVAL

PRODUCT CODE	C13XC4C
FRAME	SUPERX, BALLISTEC CARBON, SPEED SAVE, BB30
FORK	SUPERX, BALLISTEC CARBON, 1-1/8" TO 1-1/4" STEERER
RIMS	FULCRUM RACING 7 CX
HUBS	FULCRUM RACING 7
SPOKES	FULCRUM RACING 7 CX
TIRES	SCHWALBE RAPID ROB, 700X35C
PEDALS	N/A
CRANKS	FSA GOSSAMER PRO, BB30, 46/36
BOTTOM BRACKET	FSA BB30
CHAIN	KMC X10, 10-SPEED
REAR COGS	SRAM PG-1050, 11-26 10-SPEED
FRONT DERAILLEUR	SRAM RIVAL
REAR DERAILLEUR	SRAM RIVAL
SHIFTERS	SRAM RIVAL DOUBLETAP
HANDLEBAR	CANNONDALE C2 COMPACT
GRIPS	CANNONDALE BAR TAPE W/GEL, 2.5MM
STEM	CANNONDALE C2, 31.8, 6 DEG.
HEADSET	CANNONDALE SUPERX, 1-1/8" TO 1-1/4", 15MM TOP CAP
BRAKES	TRP EURO-X ALLOY
BRAKE LEVERS	SRAM RIVAL
SADDLE	FI'ZIK TUNDRA 2
SEATPOST	CANNONDALE C3 ALLOY, 27.2MMX300MM
SIZES	44,48,50,52,54,56,58CM
COLOR (CODE)	MAGNESIUM WHITE W/ JET BLACK, GLOSS (WHT)

CAADX DISC ULTEGRA

PRODUCT CODE	C13XR1C
FRAME	CAADX CYCLOCROSS DISC, OPTIMIZED 6061 ALLOY, BB30
FORK	CANNONDALE ULTRA X DISC, CARBON BLADES, 1-1/8"
RIMS	MADDUX CX 2.0 DISC
HUBS	FORMULA, DC-20LW FRONT, DC-22LW REAR
SPOKES	STAINLESS STEEL, 15G
TIRES	SCHWALBE SAMMY SLICK, 700X35C
PEDALS	WELGGO PLATFORM
CRANKS	FSA GOSSAMER PRO, BB30, 46/36
BOTTOM BRACKET	FSA BB30
CHAIN	SHIMANO 105 5700
REAR COGS	SHIMANO 105 5700, 11-28T, 10-SPEED
FRONT DERAILLEUR	SHIMANO ULTEGRA 6700, 31.8 CLAMP
REAR DERAILLEUR	SHIMANO ULTEGRA 6700
SHIFTERS	SHIMANO ULTEGRA 6700
HANDLEBAR	CANNONDALE C3 COMPACT
GRIPS	CANNONDALE 3.5MM SUEDE W/ GEL BACKING BAR TAPE
STEM	CANNONDALE C3, 31.8, 6 DEG.
HEADSET	CAADX SI, 25MM TOP CAP
BRAKES	CANNONDALE MB700T DISC
BRAKE LEVERS	SHIMANO ULTEGRA 6700
SADDLE	CANNONDALE STAGE CX W/ CRMO RAILS
SEATPOST	CANNONDALE C3, CARBON WRAP, 27.2X300MM
SIZES	44, 48, 51, 54, 56, 58, 61CM
COLOR (CODE)	BLACK ANODIZED (BLA)

CAADX 105

PRODUCT CODE	C13XR5C
FRAME	CAADX CYCLOCROSS, OPTIMIZED 6061 ALLOY, BB30
FORK	CANNONDALE ULTRA X, CARBON BLADES, 1-1/8"
RIMS	MADDUX DRX 6000, 32 HOLE
HUBS	FORMULA, RB-51 FRONT, RB-52 REAR
SPOKES	STAINLESS STEEL, 15G
TIRES	SCHWALBE SAMMY SLICK, 700X35C
PEDALS	WELGGO PLATFORM
CRANKS	FSA GOSSAMER, BB30, 46/36
BOTTOM BRACKET	FSA BB30
CHAIN	KMC X10, 10-SPEED
REAR COGS	SHIMANO TIAGRA 4600, 12-28, 10-SPEED
FRONT DERAILLEUR	SHIMANO 105 5700, 34.9MM CLAMP
REAR DERAILLEUR	SHIMANO 105 5700
SHIFTERS	SHIMANO 105 5700
HANDLEBAR	CANNONDALE C3 COMPACT
GRIPS	CANNONDALE 3.5MM SUEDE W/ GEL BACKING BAR TAPE
STEM	CANNONDALE C3, 31.8, 6 DEG.
HEADSET	CAADX SI, 25MM TOP CAP
BRAKES	TEKTRO CR710
BRAKE LEVERS	SHIMANO 105 5700
SADDLE	CANNONDALE STAGE CX W/ CRMO RAILS
SEATPOST	CANNONDALE C3 ALLOY, 27.2MMX300MM
SIZES	44, 48, 51, 54, 56, 58, 61CM
COLOR (CODE)	BRUSHED ALUMINIUM, GLOSS (RAW)

CAADX TIAGRA

PRODUCT CODE	C13XR6C
FRAME	CAADX CYCLOCROSS, OPTIMIZED 6061 ALLOY, BB30
FORK	CANNONDALE ULTRA X, CARBON BLADES, 1-1/8"
RIMS	MADDUX DRX 6000, 32 HOLE
HUBS	CANNONDALE C4
SPOKES	STAINLESS STEEL, 15G
TIRES	SCHWALBE SAMMY SLICK, 700X35C
PEDALS	WELGGO PLATFORM
CRANKS	FSA OMEGA BB30, 46/36
BOTTOM BRACKET	FSA BB30
CHAIN	KMC X10, 10-SPEED
REAR COGS	SHIMANO TIAGRA 4600, 12-28, 10-SPEED
FRONT DERAILLEUR	SHIMANO TIAGRA 4600, 34.9MM CLAMP
REAR DERAILLEUR	SHIMANO TIAGRA 4600
SHIFTERS	SHIMANO TIAGRA 4600
HANDLEBAR	CANNONDALE C4 COMPACT
GRIPS	CANNONDALE 3.5MM SUEDE W/ GEL BACKING BAR TAPE
STEM	CANNONDALE C4, 31.8, 6 DEG.
HEADSET	CAADX SI, 25MM TOP CAP
BRAKES	TEKTRO CR520
BRAKE LEVERS	SHIMANO TIAGRA 4600
SADDLE	CANNONDALE STAGE CX W/ STEEL RAILS
SEATPOST	CANNONDALE C4 ALLOY, 27.2MMX300MM
SIZES	44, 48, 51, 54, 56, 58, 61CM
COLOR (CODE)	JET BLACK, MATTE (BBQ)
EXTRAS	N/A

URBAN SPECIFICATIONS

E-BIKE 1

PRODUCT CODE	C12EBM1
FRAME	E-SERIES SI HEADSHOK, MEN'S SPECIFIC W/ INTEGRATED RACK
FORK	HEADSHOK FATTY DL50, 50MM W/LOCKOUT, (DL50 XL FOR SIZE 55, 60)
RIMS	MADDUX C2 URBAN
HUBS	SHIMANO M525
SPOKES	STAINLESS XD BLACK, 15G
TIRES	SCHWALBE MARATHON SUPREME 700X35C
PEDALS	CANNONDALE QUICK
CRANKS	FSA METROPOLIS, BOSCH SPECIFIC
BOTTOM BRACKET	BOSCH INTEGRATED DRIVE UNIT MOTOR
CHAIN	SHIMANO HG53
REAR COGS	SHIMANO HG50 11-32, 9-SPEED.
FRONT DERAILLEUR	N/A
REAR DERAILLEUR	SHIMANO SLX
SHIFTERS	SHIMANO DEORE
HANDLEBAR	CANNONDALE TREKKING BLACK, 610MM
GRIPS	CANNONDALE ERGO PERFORMANCE, LOCK ON
STEM	CANNONDALE C3 HEADSHOK ADJUSTABLE BLACK
HEADSET	TANGE SI HEADSHOK
BRAKES	MAGURA MT2 HYDRAULIC DISC, 160/160MM
BRAKE LEVERS	MAGURA MT2 HYDRAULIC DISC
SADDLE	SELLE ROYAL FRECCIA
SEATPOST	CANNONDALE C2, 2 BOLT, ALLOY
SIZES	50, 55, 60 / WOMEN'S 45, 50, 55
COLOR (CODE)	JET BLACK, MATTE (BBQ)
EXTRAS	CURANA FENDERS & CHAINCASE, TRELLOCK LIGHT, AXA LOCK, BIBIA BELL AND CANNONDALE PUMP, INTEGRATED RACK MOUNTED BATTERY; 37V LI-ION, 288 WH

E-BIKE 2

PRODUCT CODE	C12EBM2
FRAME	E-SERIES SI HEADSHOK, MEN'S SPECIFIC W/ INTEGRATED RACK
FORK	HEADSHOK FATTY DL50, 50MM W/LOCKOUT, (DL50 XL FOR SIZE 55, 60)
RIMS	MADDUX C2 URBAN
HUBS	SHIMANO ALFINE DYNAMO HUB FRONT, SHIMANO M525 REAR
SPOKES	STAINLESS XD BLACK, 15G
TIRES	SCHWALBE MARATHON SUPREME 700X35C
PEDALS	CANNONDALE QUICK
CRANKS	FSA METROPOLIS, BOSCH SPECIFIC
BOTTOM BRACKET	BOSCH INTEGRATED DRIVE UNIT MOTOR
CHAIN	SHIMANO HG53
REAR COGS	SHIMANO HG50 11-32, 9-SPEED.
FRONT DERAILLEUR	N/A
REAR DERAILLEUR	SHIMANO SLX
SHIFTERS	SHIMANO DEORE
HANDLEBAR	CANNONDALE TREKKING BLACK, 610MM
GRIPS	CANNONDALE ERGO PERFORMANCE, LOCK ON
STEM	CANNONDALE C3 HEADSHOK ADJUSTABLE BLACK
HEADSET	TANGE SI HEADSHOK
BRAKES	MAGURA MT2 HYDRAULIC DISC, 160/160MM
BRAKE LEVERS	MAGURA MT2 HYDRAULIC DISC
SADDLE	SELLE ROYAL FRECCIA
SEATPOST	CANNONDALE C2, 2 BOLT, ALLOY
SIZES	50, 55, 60 / WOMEN'S 45, 50, 55
COLOR (CODE)	JET BLACK, MATTE (BBQ)
EXTRAS	CURANA FENDERS & CHAINCASE, TRELLOCK LIGHT, AXA LOCK, BIBIA BELL AND CANNONDALE PUMP, INTEGRATED RACK MOUNTED BATTERY; 37V LI-ION, 288 WH

URBAN SPECIFICATIONS

E-BIKE 1 ALFINE 8	
PRODUCT CODE	C12EBM8
FRAME	E-SERIES SI HEADSHOK, MEN'S SPECIFIC W/ INTEGRATED RACK
FORK	HEADSHOK FATTY DL50, 50MM W/LOCKOUT, (DL50 XL FOR SIZE 55, 60)
RIMS	MADDEX C2 URBAN
HUBS	SHIMANO ALFINE INTERNAL 8 REAR, M525 FRONT
SPOKES	STAINLESS XD BLACK, 15G
TIRES	SCHWALBE MARATHON SUPREME 700X35C
PEDALS	CANNONDALE QUICK
CRANKS	FSA METROPOLIS, BOSCH SPECIFIC
BOTTOM BRACKET	BOSCH INTEGRATED DRIVE UNIT MOTOR
CHAIN	SHIMANO HG53
REAR COGS	ALFINE 18T
FRONT DERAILLEUR	N/A
REAR DERAILLEUR	N/A
SHIFTERS	SHIMANO ALFINE 8, RAPIDFIRE PLUS
HANDLEBAR	CANNONDALE TREKKING BLACK, 610MM
GRIPS	CANNONDALE ERGO PERFORMANCE, LOCK ON
STEM	CANNONDALE C3 HEADSHOK ADJUSTABLE BLACK
HEADSET	TANGE SI HEADSHOK
BRAKES	MAGURA MT2 HYDRAULIC DISC, 160/160MM
BRAKE LEVERS	MAGURA MT2 HYDRAULIC DISC
SADDLE	SELLE ROYAL FRECCIA
SEATPOST	CANNONDALE C2, 2 BOLT, ALLOY
SIZES	50, 55, 60 / WOMEN'S 45, 50, 55
COLOR (CODE)	JET BLACK, MATTE (BBQ)
EXTRAS	CURANA FENDERS & CHAINCASE, TRELLOCK LIGHT, AXA LOCK, BIBIA BELL AND CANNONDALE PUMP, INTEGRATED RACK MOUNTED BATTERY, 37V LI-ION, 288 WH

BAD BOY 4	
PRODUCT CODE	C13BB4
FRAME	BAD BOY STEALTH, OPTIMIZED 6061 ALLOY, 1.5 SI HEAD TUBE
FORK	CANNONDALE FATTY RIGID OPI, 1.5" STEERER
RIMS	CANNONDALE C2 URBAN SL, 32 HOLE
HUBS	SHIMANO M475
SPOKES	STAINLESS XD BLACK, 15G
TIRES	SCHWALBE KOJAK RACE GUARD, 700X28C
PEDALS	CANNONDALE URBAN 6POINT3 ALLOY
CRANKS	SHIMANO DEORE, 48/36/26
BOTTOM BRACKET	SHIMANO DEORE
CHAIN	KMC Z99 BLACK, 9-SPEED
REAR COGS	SHIMANO HG81, 11-34, 9-SPEED
FRONT DERAILLEUR	SHIMANO DEORE, 34.9MM CLAMP
REAR DERAILLEUR	SHIMANO SLX, SHADOW
SHIFTERS	SHIMANO DEORE
HANDLEBAR	CANNONDALE SI URBAN OPI STEM/HANDLEBAR W/ SI LIGHT, 7 DEG.
GRIPS	CANNONDALE URBAN, LOCK-ON
STEM	CANNONDALE SI URBAN OPI STEM/HANDLEBAR W/ LIGHT, 7 DEG.
HEADSET	TANGE CUSTOM 1.5"
BRAKES	SHIMANO M446 HYDRAULIC DISC
BRAKE LEVERS	MAGURA MT2 HYDRAULIC DISC
SADDLE	CANNONDALE BAD BOY URBAN
SEATPOST	CANNONDALE C2, 2 BOLT, ALLOY, 31.6 X 350MM
SIZES	S, M, L, X
COLOR (CODE)	JET BLACK W/REFLECTIVE DECALS, MATTE (BBQ)

HOOLIGAN 1	
PRODUCT CODE	C13HL1
FRAME	HOOLIGAN DELTA V, URBAN COMPACT, 20" WHEEL, 1.5 SI HEAD TUBE
FORK	CANNONDALE SOLO RIGID, OPI, 1.5" STEERER
RIMS	CANNONDALE DC3.0, 20", 32 HOLE
HUBS	CANNONDALE LEFTY SL FRONT, SHIMANO NEXUS 3-SPEED, CENTERLOCK DISC REAR
SPOKES	STAINLESS XD BLACK, 15G
TIRES	KENDA QUEST, 20 X 1.5"
PEDALS	CANNONDALE URBAN 6POINT3 ALLOY
CRANKS	FSA VERO, SINGLE RING, DUAL ALLOY CHAINGUARD, 48T
BOTTOM BRACKET	CANNONDALE TP148 ECCENTRIC, TANGE CARTRIDGE, JIS
CHAIN	KMC Z72
REAR COGS	SHIMANO 16T
FRONT DERAILLEUR	N/A
REAR DERAILLEUR	N/A
SHIFTERS	SHIMANO NEXUS REVO 3-SPEED
HANDLEBAR	CANNONDALE URBAN 6061, 620MM
GRIPS	CANNONDALE URBAN, LOCK-ON
STEM	CANNONDALE C3 ADJUSTABLE, 1.5", 3-D FORGED
HEADSET	TANGE CUSTOM 1.5"
BRAKES	SHIMANO M375 MECHANICAL DISC, 160/160MM
BRAKE LEVERS	CANNONDALE C3
SADDLE	CANNONDALE HOOLIGAN URBAN
SEATPOST	CANNONDALE C3, 2 BOLT, ALLOY 31.6 X 520MM
SIZES	ONE SIZE
COLOR (CODE)	JET BLACK, MATTE (BBQ)
EXTRAS	INTEGRATED SLIDE2GO ACCESSORY MOUNT

E-BIKE 1 ALFINE 8 GER	
PRODUCT CODE	C12EBM8D
FRAME	E-SERIES SI HEADSHOK, MEN'S SPECIFIC W/ INTEGRATED RACK
FORK	HEADSHOK FATTY DL50, 50MM W/LOCKOUT, (DL50 XL FOR SIZE 55, 60)
RIMS	MADDEX C2 URBAN
HUBS	SHIMANO ALFINE INTERNAL 8 REAR, ALFINE DYNAMO HUB FRONT
SPOKES	STAINLESS XD BLACK, 15G
TIRES	SCHWALBE MARATHON SUPREME 700X35C
PEDALS	CANNONDALE QUICK
CRANKS	FSA METROPOLIS, BOSCH SPECIFIC
BOTTOM BRACKET	BOSCH INTEGRATED DRIVE UNIT MOTOR
CHAIN	SHIMANO HG53
REAR COGS	ALFINE 18T
FRONT DERAILLEUR	N/A
REAR DERAILLEUR	N/A
SHIFTERS	SHIMANO ALFINE 8, RAPIDFIRE PLUS
HANDLEBAR	CANNONDALE TREKKING BLACK, 610MM
GRIPS	CANNONDALE ERGO PERFORMANCE, LOCK ON
STEM	CANNONDALE C3 HEADSHOK ADJUSTABLE BLACK
HEADSET	TANGE SI HEADSHOK
BRAKES	MAGURA MT2 HYDRAULIC DISC, 160/160MM
BRAKE LEVERS	MAGURA MT2 HYDRAULIC DISC
SADDLE	SELLE ROYAL FRECCIA
SEATPOST	CANNONDALE C2, 2 BOLT, ALLOY
SIZES	50, 55, 60 / WOMEN'S 45, 50, 55
COLOR (CODE)	JET BLACK, MATTE (BBQ)
EXTRAS	CURANA FENDERS & CHAINCASE, TRELLOCK LIGHT, AXA LOCK, BIBIA BELL AND CANNONDALE PUMP, INTEGRATED RACK MOUNTED BATTERY, 37V LI-ION, 288 WH

BAD BOY 6	
PRODUCT CODE	C13BB6
FRAME	BAD BOY, OPTIMIZED 6061 ALLOY, 1-1/8" HEAD TUBE
FORK	CANNONDALE FATTY RIGID, 26", 1-1/8" STEERER
RIMS	CANNONDALE C3 URBAN SL, 32 HOLE
HUBS	SHIMANO RM66 FRONT, RM66 REAR
SPOKES	STAINLESS XD BLACK, 15G
TIRES	SCHWALBE KOJAK RACE GUARD, 700X28C
PEDALS	CANNONDALE URBAN 6POINT3 COMPOSITE
CRANKS	SHIMANO M431, BAD BOY, 48/36/26
BOTTOM BRACKET	TANGE CARTRIDGE
CHAIN	KMC Z99 BLACK, 9-SPEED
REAR COGS	SHIMANO HG50, 11-31, 9-SPEED
FRONT DERAILLEUR	SHIMANO ACERA, 34.9MM CLAMP
REAR DERAILLEUR	SHIMANO DEORE
SHIFTERS	SHIMANO ACERA
HANDLEBAR	CANNONDALE C4 ALLOY, FLAT, 620MM
GRIPS	CANNONDALE URBAN, LOCK-ON
STEM	CANNONDALE C4, 31.8, 6 DEG
HEADSET	TANGE SI 1-1/8"
BRAKES	CANNONDALE C4 V-BRAKE
BRAKE LEVERS	SHIMANO M395 HYDRAULIC DISC
SADDLE	CANNONDALE BAD BOY URBAN
SEATPOST	CANNONDALE C4, ALLOY, 31.6 X 350MM
SIZES	S, M, L, X
COLOR (CODE)	JET BLACK W/REFLECTIVE DECALS, MATTE (BBQ)

QUICK SPEED 1	
PRODUCT CODE	C13QS1
FRAME	QUICK FULL CARBON W/ SAVE FEATURES
FORK	QUICK FULL CARBON SI 1 1/8"
RIMS	DT SWISS R1800 WHITE
HUBS	DT SWISS R1800 WHITE
SPOKES	DT SWISS R1800 WHITE
TIRES	SCHWALBE MARATHON SUPREME, 700X28C
PEDALS	CANNONDALE URBAN 6POINT3 ALLOY
CRANKS	FSA SL-K, BB30, 50/34
BOTTOM BRACKET	FSA SL-K, BB30
CHAIN	SHIMANO ULTEGRA 6700, 10-SPEED
REAR COGS	SHIMANO ULTEGRA 6700 12-25, 10-SPEED
FRONT DERAILLEUR	SHIMANO ULTEGRA
REAR DERAILLEUR	SHIMANO ULTEGRA
SHIFTERS	SHIMANO RL-770
HANDLEBAR	CANNONDALE C2 FLATBAR
GRIPS	CANNONDALE CITYSCAPE GRIPS
STEM	CANNONDALE C2 6 DEGREE
HEADSET	TANGE SEMI-INTEGRATED
BRAKES	TEKTRO TRP CX9
BRAKE LEVERS	TEKTRO TRP ML940
SADDLE	FIZIK ALIANTE
SEATPOST	CANNONDALE QUICK FULL CARBON
SIZES	46, 51, 57
COLOR (CODE)	BLACK CARBON (MATTE)
EXTRAS	N/A

BAD BOY 0	
PRODUCT CODE	C13BB0
FRAME	BAD BOY STEALTH, OPTIMIZED 6061 ALLOY, HEADSHOK, EBB
FORK	HEADSHOK SOLO DL50, 50MM W/LOCKOUT, OPI
RIMS	CANNONDALE C2 URBAN SL, 32 HOLE
HUBS	CANNONDALE LEFTY SL FRONT, SHIMANO ALFINE 11 REAR
SPOKES	STAINLESS XD BLACK, 15G
TIRES	SCHWALBE KOJAK RACE GUARD, 700X28C
PEDALS	CANNONDALE URBAN 6POINT3 ALLOY
CRANKS	TRUVATIV FIREX, 42T
BOTTOM BRACKET	TRUVATIV GXP
CHAIN	KMC Z610 BLACK
REAR COGS	SHIMANO ALFINE 18T
FRONT DERAILLEUR	N/A
REAR DERAILLEUR	N/A
SHIFTERS	SHIMANO ALFINE 11 RAPIDFIRE, 11-SPEED
HANDLEBAR	CANNONDALE SI URBAN OPI STEM/HANDLEBAR W/ SI LIGHT, 7 DEG.
GRIPS	CANNONDALE URBAN, LOCK-ON
STEM	CANNONDALE SI URBAN OPI STEM/HANDLEBAR W/ LIGHT, 7 DEG.
HEADSET	CANNONDALE HEADSHOK SI
BRAKES	MAGURA MT2 HYDRAULIC DISC
BRAKE LEVERS	MAGURA MT2 HYDRAULIC DISC
SADDLE	CANNONDALE BAD BOY URBAN
SEATPOST	CANNONDALE C2, 2 BOLT, ALLOY, 31.6 X 350MM
SIZES	S, M, L, X
COLOR (CODE)	BLACK ANODIZED W/REFLECTIVE DECALS, MATTE (BBQ)
EXTRAS	N/A

BAD BOY 7	
PRODUCT CODE	C13BB7
FRAME	BAD BOY 26", OPTIMIZED 6061 ALLOY, 1-1/8" HEAD TUBE
FORK	CANNONDALE FATTY RIGID, 26", 1-1/8" STEERER
RIMS	CANNONDALE C3 URBAN SL 26", 32 HOLE
HUBS	SHIMANO RM40 FRONT, RM30 REAR
SPOKES	STAINLESS XD BLACK, 15G
TIRES	SCHWALBE KOJAK RACE GUARD, 26X2.0"
PEDALS	CANNONDALE URBAN 6POINT3 COMPOSITE
CRANKS	SHIMANO ACERA 48/36/26
BOTTOM BRACKET	TANGE CARTRIDGE
CHAIN	KMC Z99 BLACK, 9-SPEED
REAR COGS	SHIMANO HG50, 11-31, 9-SPEED
FRONT DERAILLEUR	SHIMANO ACERA, 34.9MM CLAMP
REAR DERAILLEUR	SHIMANO ACERA
SHIFTERS	CANNONDALE C4 ALLOY, FLAT, 620MM
HANDLEBAR	CANNONDALE URBAN, LOCK-ON
GRIPS	CANNONDALE C4, 31.8, 6 DEG
STEM	TANGE SI 1-1/8"
HEADSET	CANNONDALE C4 V-BRAKE
BRAKES	CANNONDALE C4
BRAKE LEVERS	CANNONDALE BAD BOY URBAN
SADDLE	CANNONDALE C4, ALLOY, 31.6 X 350MM
SEATPOST	S, M, L, X
SIZES	JET BLACK W/REFLECTIVE DECALS, MATTE (BBQ)

QUICK SPEED 2	
PRODUCT CODE	C13QS2
FRAME	QUICK SL, OPTIMIZED 6061 ALLOY, SAVE, 1-1/8" HEAD TUBE
FORK	QUICK SI, CARBON BLADES, 1-1/8" STEERER, W/ LOW RIDER MOUNTS
RIMS	MADDEX RS 3.0, DOUBLE WALL, EYELETED, 32 HOLE
HUBS	SHIMANO 105
SPOKES	STAINLESS STEEL XD BLACK W/ ALLOY NIPPLES, 15G
TIRES	SCHWALBE MARATHON SUPREME, 700X28C
PEDALS	CANNONDALE URBAN 6POINT3 ALLOY
CRANKS	SHIMANO 105 5700, 50/34
BOTTOM BRACKET	SHIMANO 105 5700
CHAIN	KMC X10, 10-SPEED
REAR COGS	SHIMANO TIAGRA 12-28, 10-SPEED
FRONT DERAILLEUR	SHIMANO 105 5700, 31.8 CLAMP
REAR DERAILLEUR	SHIMANO 105 5700
SHIFTERS	SHIMANO TIAGRA 4600 FLATBAR
HANDLEBAR	CANNONDALE C2 FLATBAR, 620MM
GRIPS	CANNONDALE ERGO PERFORMANCE, LOCK ON
STEM	CANNONDALE C3, 31.8, 6 DEG.
HEADSET	TANGE SI
BRAKES	CANNONDALE C2 MINI V, CARTRIDGE PADS
BRAKE LEVERS	TEKTRO MT5.0 CARBON
SADDLE	CANNONDALE QUICK SPEED ERGO
SEATPOST	CANNONDALE C3, 6061 ALLOY, 2 BOLT, 31.6 X 350MM
SIZES	48, 52, 56, 60 CM
COLOR (CODE)	BRUSHED ALUMINUM, GLOSS (RAW)
EXTRAS	N/A

BAD BOY 2	
PRODUCT CODE	C13BB2
FRAME	BAD BOY STEALTH, OPTIMIZED 6061 ALLOY, 1.5 SI HEAD TUBE
FORK	HEADSHOK FATTY DL50, 50MM W/LOCKOUT, OPI
RIMS	CANNONDALE C2 URBAN SL, 32 HOLE
HUBS	SHIMANO M525
SPOKES	STAINLESS XD BLACK, 15G
TIRES	SCHWALBE KOJAK RACE GUARD, 700X28C
PEDALS	CANNONDALE URBAN 6POINT3 ALLOY
CRANKS	FSA COMET 42/32/24
BOTTOM BRACKET	TANGE CARTRIDGE
CHAIN	KMC X10 BLACK, 10-SPEED
REAR COGS	SHIMANO ALFINE 18T
FRONT DERAILLEUR	SHIMANO DEORE, 34.9MM CLAMP
REAR DERAILLEUR	SHIMANO SLX, SHADOW
SHIFTERS	SHIMANO DEORE
HANDLEBAR	CANNONDALE SI URBAN OPI STEM/HANDLEBAR W/ SI LIGHT, 7 DEG.
GRIPS	CANNONDALE URBAN, LOCK-ON
STEM	CANNONDALE SI URBAN OPI STEM/HANDLEBAR W/ LIGHT, 7 DEG.
HEADSET	TANGE CUSTOM 1.5"
BRAKES	SHIMANO M446 HYDRAULIC DISC
BRAKE LEVERS	MAGURA MT2 HYDRAULIC DISC
SADDLE	CANNONDALE BAD BOY URBAN
SEATPOST	CANNONDALE C2, 2 BOLT, ALLOY, 31.6 X 350MM
SIZES	S, M, L, X
COLOR (CODE)	BLACK ANODIZED W/REFLECTIVE DECALS, MATTE (BBQ)
EXTRAS	N/A

BAD GIRL 2	
PRODUCT CODE	C13BWF2
FRAME	BAD GIRL, OPTIMIZED 6061 ALLOY, 1-1/8" HEAD TUBE
FORK	CANNONDALE FATTY RIGID, 1-1/8" STEERER
RIMS	MADDEX C3 URBAN, 32 HOLE
HUBS	CANNONDALE C4
SPOKES	STAINLESS XD BLACK, 15G
TIRES	FREEDOM THICK SLICK, 700X28C
PEDALS	CANNONDALE URBAN PLATFORM
CRANKS	FSA VERO SINGLE SPEED, 42
BOTTOM BRACKET	TANGE SEKI CARTRIDGE BB
CHAIN	KMC X-10, BLACK, 10-SPEED
REAR COGS	SRAM PG-1030, 11-36, 10-SPEED
FRONT DERAILLEUR	N/A
REAR DERAILLEUR	SHIMANO DEORE
SHIFTERS	SHIMANO DEORE
HANDLEBAR	CANNONDALE C3 ALLOY, FLAT, 600MM
GRIPS	CANNONDALE SI URBAN OPI STEM/HANDLEBAR, 7 DEG.
STEM	CANNONDALE CITYSCAPE URBAN LOCK-ON GRIPS
HEADSET	TANGE 1-1/8" SEMI INTEGRATED
BRAKES	CANNONDALE HELIX 6 HYDRAULIC DISC, 160/160MM
BRAKE LEVERS	CANNONDALE HELIX 6 HYDRAULIC DISC
SADDLE	CANNONDALE BAD GIRL
SEATPOST	CANNONDALE C4, 31.6X350MM
SIZES	S, T
COLOR (CODE)	JET BLACK W/REFLECTIVE DECALS, MATTE (BBQ)

QUICK SPEED 3	
PRODUCT CODE	C13QS3
FRAME	QUICK SL, EBB, OPTIMIZED 6061 ALLOY, SAVE, 1-1/8" HEAD TUBE
FORK	QUICK SI, CARBON BLADES, 1-1/8" STEERER, W/ LOW RIDER MOUNTS
RIMS	MADDEX TC5.0, DOUBLE WALL W/EYELET, 32 HOLE
HUBS	SHIMANO ALIVIO FRONT, NEXUS INTER-8 REAR
SPOKES	STAINLESS STEEL XD BLACK W/ ALLOY NIPPLES, 15G
TIRES	SCHWALBE MARATHON SUPREME, 700X28C
PEDALS	CANNONDALE URBAN 6POINT3 ALLOY
CRANKS	TRUVATIV FIREX 1.1G, 42T
BOTTOM BRACKET	CANNONDALE TP148 ECCENTRIC, TRUVATIV GXP
CHAIN	KMC Z51, BLACK
REAR COGS	SHIMANO NEXUS 18T
FRONT DERAILLEUR	N/A
REAR DERAILLEUR	N/A
SHIFTERS	SHIMANO NEXUS 8-SPEED
HANDLEBAR	CANNONDALE C3 FLATBAR, 620MM
GRIPS	CANNONDALE ERGO PERFORMANCE, LOCK ON
STEM	FSA VARIUS OS, ADJUSTABLE, 31.8

URBAN SPECIFICATIONS

	QUICK SPEED 4
PRODUCT CODE	C130S4
FRAME	QUICK SL, OPTIMIZED 6061 ALLOY, SAVE, 1-1/8" HEAD TUBE
FORK	QUICK SL, CARBON BLADES, 1-1/8" STEERER, W/ LOW RIDER MOUNTS
REAR SHOCK	N/A
RIMS	MADDUX TC5.0, DOUBLE WALL W/EYELET, 32 HOLE
HUBS	SHIMANO TIAGRA
SPOKES	STAINLESS STEEL XD BLACK W/ ALLOY NIPPLES, 15G
TIRES	SCHWALBE MARATHON SUPREME, 700X28C
PEDALS	CANNONDALE URBAN 6POINT3 ALLOY
CRANKS	SHIMANO TIAGRA, 50/34
BOTTOM BRACKET	SHIMANO TIAGRA
CHAIN	KMC X10, 10-SPEED
REAR COGS	SHIMANO TIAGRA 12-28, 10-SPEED
FRONT DERAILLEUR	SHIMANO TIAGRA, 31.8 CLAMP
REAR DERAILLEUR	SHIMANO TIAGRA
SHIFTERS	SHIMANO TIAGRA 4600 FLATBAR
HANDLEBAR	CANNONDALE C3, FLATBAR, 620MM
GRIPS	CANNONDALE ERGO PERFORMANCE, LOCK ON
STEM	CANNONDALE C3, 31.8, 6 DEG.
HEADSET	TANGE SI
BRAKES	CANNONDALE C2 MINI V, CARTRIDGE PADS
BRAKE LEVERS	CANNONDALE CBL 9.1
SADDLE	CANNONDALE QUICK SPEED ERGO
SEATPOST	CANNONDALE C4, 6061 ALLOY, 31.6 X 350MM
SIZES	48, 52, 56, 60 CM
COLOR (CODE)	JET BLACK, MATTE (BBQ)

	QUICK CX 4
PRODUCT CODE	C130X4
FRAME	QUICK CX RIGID, OPTIMIZED 6061 ALLOY, SAVE, 1-1/8" HEAD TUBE
FORK	FATTY RIGID DISC, ALLOY, 1-1/8" STEERER
RIMS	MADDUX TC 5.0, DOUBLE WALL, EYELET, MACHINED SIDEWALL, 32 HOLE
HUBS	CANNONDALE C4
SPOKES	STAINLESS STEEL XD BLACK, 15G
TIRES	SCHWALBE SAMMY SLICK, 700X35C
PEDALS	CANNONDALE URBAN 6POINT3 COMPOSITE
CRANKS	SHIMANO M171 48/38/28
BOTTOM BRACKET	TANGE CARTRIDGE
CHAIN	KMC Z82, 8-SPEED
REAR COGS	SUNRACE CSG66 11-32, 8 SPD
FRONT DERAILLEUR	SHIMANO ALIVIO, 31.8 CLAMP
REAR DERAILLEUR	SHIMANO ALIVIO
SHIFTERS	SHIMANO ALTUS
HANDLEBAR	CANNONDALE C4, 6061, 25MM RISE, 620MM
GRIPS	CANNONDALE ERGO PERFORMANCE
STEM	CANNONDALE C4, 1-1/8", 31.8, 12 DEG
HEADSET	TANGE 1-1/8"
BRAKES	TEKTRO 855 V-BRAKE
BRAKE LEVERS	CANNONDALE C4
SADDLE	CANNONDALE QUICK CX ERGO
SEATPOST	CANNONDALE C4, ALLOY, 31.6 X 350MM
SIZES	48, 52, 56, 60
COLOR (CODE)	STEALTH GREY, MATTE (GRY)
EXTRAS	N/A

	TESORO 3
PRODUCT CODE	C12TS4
FRAME	TESORO SI, OPTIMIZED 6061 ALLOY, SAVE
FORK	CANNONDALE FATTY RIGID ALLOY
REAR SHOCK	N/A
RIMS	CANNONDALE TC05, DOUBLE WALL, EYELETED, 32 HOLE
HUBS	SHIMANO ALIVIO
SPOKES	STAINLESS STEEL XD BLACK W/ RED NIPPLES, 15G
TIRES	SCHWALBE MARATHON SUPREME, 700X35C
PEDALS	CANNONDALE URBAN 6POINT3 ALLOY
CRANKS	SHIMANO ALIVIO
BOTTOM BRACKET	SHIMANO ALIVIO
CHAIN	SHIMANO HG53, 9-SPEED
REAR COGS	SHIMANO HG30 11-32, 9-SPEED
FRONT DERAILLEUR	SHIMANO ACERA
REAR DERAILLEUR	SHIMANO ALIVIO
SHIFTERS	SHIMANO ACERA
HANDLEBAR	CANNONDALE TREKKING BLACK
GRIPS	CANNONDALE ERGO PERFORMANCE, LOCK ON
STEM	CANNONDALE UP C3 ADJUSTABLE BLACK
HEADSET	TANGE SEMI-INTEGRATED
BRAKES	AVID SINGLE DIGIT 5
BRAKE LEVERS	AVID FR5
SADDLE	CANNONDALE QUICK CX
SEATPOST	CANNONDALE C3, 6061 ALLOY, 2 BOLT, 31.6 X 350MM
SIZES	48, 52, 56, 60
COLOR (CODE)	FINE SILVER, GLOSS (SLV)
EXTRAS	TUBUS RACK, BUSCH & MULLER LIGHTS, CURANA FENDERS & CHAINCASE

	QUICK CX 1
PRODUCT CODE	C130X1
FRAME	QUICK CX, OPTIMIZED 6061 ALLOY, SAVE, HEADSHOK
FORK	HEADSHOK FATTY DL50, 50MM W/LOCKOUT, OPI
REAR SHOCK	N/A
RIMS	MADDUX DC3.0, DOUBLE WALL W/EYELET, 32 HOLE
HUBS	SHIMANO SLX M665 CENTERLOCK DISC
SPOKES	STAINLESS STEEL XD BLACK, 15G
TIRES	SCHWALBE MARATHON SUPREME, 700X35C
PEDALS	CANNONDALE URBAN 6POINT3 ALLOY PLATFORM
CRANKS	SHIMANO SLX, 42/32/22
BOTTOM BRACKET	SHIMANO SLX
CHAIN	SHIMANO HG74, 10-SPEED
REAR COGS	SHIMANO SLX HG81, 11-32, 10-SPEED
FRONT DERAILLEUR	SHIMANO SLX, 31.8 CLAMP
REAR DERAILLEUR	SHIMANO XT
SHIFTERS	SHIMANO SLX
HANDLEBAR	CANNONDALE C3, BUTTED 6061 ALLOY, 5MM RISE, 600MM
GRIPS	CANNONDALE ERGO PERFORMANCE, LOCK ON
STEM	CANNONDALE C3, HEADSHOK 3-D FORGED 31.8, 7 DEG.
HEADSET	CANNONDALE HEADSHOK SI
BRAKES	MAGURA MT4 HYDRAULIC DISC
BRAKE LEVERS	MAGURA MT4
SADDLE	CANNONDALE QUICK CX ERGO
SEATPOST	CANNONDALE C3, 2 BOLT, 2014 ALLOY, 31.6 X 350MM,
SIZES	48, 52, 56, 60
COLOR (CODE)	BRUSHED ALUMINUM, GLOSS (RAW)

	TESORO 1
PRODUCT CODE	C12TS0
FRAME	TESORO SI, HEADSHOK, OPTIMIZED 6061 ALLOY, SAVE, EBB
FORK	HEADSHOK FATTY DL50, 50MM W/LOCKOUT, OPI
RIMS	CANNONDALE TC05, DOUBLE WALL, EYELETED, 32 HOLE
HUBS	SHIMANO ALFINE
SPOKES	STAINLESS STEEL XD BLACK W/ RED NIPPLES, 15G
TIRES	SCHWALBE MARATHON SUPREME, 700X35C
PEDALS	CANNONDALE URBAN 6POINT3 ALLOY
CRANKS	TRUVATIV FIREX, 42T
BOTTOM BRACKET	TRUVATIV GXP
CHAIN	KMC Z610H BLACK
REAR COGS	SHIMANO ALFINE 18T
FRONT DERAILLEUR	N/A
REAR DERAILLEUR	N/A
SHIFTERS	SHIMANO ALFINE 11
HANDLEBAR	CANNONDALE TREKKING BLACK
GRIPS	CANNONDALE ERGO PERFORMANCE, LOCK ON
STEM	CANNONDALE UP C3 ADJUSTABLE BLACK
HEADSET	TANGE SEMI-INTEGRATED
BRAKES	MAGURA MT2
BRAKE LEVERS	MAGURA MT2
SADDLE	CANNONDALE QUICK CX
SEATPOST	CANNONDALE C3, 6061 ALLOY, 2 BOLT, 31.6 X 350MM
SIZES	48, 52, 56, 60
COLOR (CODE)	BRUSHED ALUMINUM, GLOSS (RAW)
EXTRAS	TUBUS RACK, BUSCH & MULLER LIGHTS, CURANA FENDERS & CHAINCASE

	QUICK CX 2
PRODUCT CODE	C130X2
FRAME	QUICK CX, OPTIMIZED 6061 ALLOY, SAVE, 1.5" HEAD TUBE
FORK	RST NEON PRO CUSTOM 1.5" TREKKING, TNL LOCKOUT, 50MM
REAR SHOCK	MADDUX DC3.0, DOUBLE WALL W/EYELET, 32 HOLE
RIMS	SHIMANO DEORE M525 CENTERLOCK DISC
HUBS	STAINLESS STEEL XD BLACK, 15G
SPOKES	SCHWALBE SAMMY SLICK, 700X35C
TIRES	SCHWALBE MARATHON SUPREME, 700X35C
PEDALS	CANNONDALE URBAN 6POINT3 ALLOY PLATFORM
CRANKS	SHIMANO DEORE M591, 48/36/26
BOTTOM BRACKET	SHIMANO DEORE
CHAIN	SHIMANO HG53, 9-SPEED
REAR COGS	SHIMANO HG50, 11-32, 9-SPEED
FRONT DERAILLEUR	SHIMANO DEORE, 31.8 CLAMP
REAR DERAILLEUR	SHIMANO SLX
SHIFTERS	SHIMANO DEORE
HANDLEBAR	CANNONDALE C3, BUTTED 6061 ALLOY, 5MM RISE, 600MM
GRIPS	CANNONDALE ERGO PERFORMANCE, LOCK ON
STEM	CANNONDALE C3, 1.5", 3-D FORGED, 31.8, 7 DEG.
HEADSET	TANGE CUSTOM 1.5"
BRAKES	MAGURA MT2 HYDRAULIC DISC
BRAKE LEVERS	SHIMANO M446 HYDRAULIC DISC
SADDLE	CANNONDALE QUICK CX ERGO
SEATPOST	CANNONDALE C3, 2 BOLT, 2014 ALLOY, 31.6 X 350MM,
SIZES	48, 52, 56, 60
COLOR (CODE)	MAGNESIUM WHITE, GLOSS (WHT)
EXTRAS	BRUSHED ALUMINUM, GLOSS (RAW)

	TESORO 2
PRODUCT CODE	C12TS3
FRAME	TESORO SI, OPTIMIZED 6061 ALLOY, SAVE
FORK	CANNONDALE SI CARBON BLADES
RIMS	CANNONDALE TC05, DOUBLE WALL, EYELETED, 32 HOLE
HUBS	SHIMANO DEORE
SPOKES	STAINLESS STEEL XD BLACK W/ RED NIPPLES, 15G
TIRES	SCHWALBE MARATHON SUPREME, 700X35C
PEDALS	CANNONDALE URBAN 6POINT3 ALLOY
CRANKS	FSA COMET 46/36/28
BOTTOM BRACKET	FSA MEGAEXO
CHAIN	KMC X10, 10-SPEED
REAR COGS	SHIMANO 4600 12-30T, 10-SPEED
FRONT DERAILLEUR	SHIMANO SLX
REAR DERAILLEUR	SHIMANO XT
SHIFTERS	SHIMANO SLX
HANDLEBAR	CANNONDALE TREKKING BLACK
GRIPS	CANNONDALE ERGO PERFORMANCE, LOCK ON
STEM	CANNONDALE UP C3 ADJUSTABLE BLACK
HEADSET	TANGE SEMI-INTEGRATED
BRAKES	MAGURA HS11
BRAKE LEVERS	MAGURA HS11
SADDLE	CANNONDALE QUICK CX
SEATPOST	CANNONDALE C3, 6061 ALLOY, 2 BOLT, 31.6 X 350MM
SIZES	48, 52, 56, 60
COLOR (CODE)	JET BLACK, GLOSS (BLK)
EXTRAS	TUBUS RACK, BUSCH & MULLER LIGHTS, CURANA FENDERS & CHAINCASE

WOMEN'S SPECIFICATIONS

	SCARLET 1
PRODUCT CODE	C13VNW1
FRAME	SCARLET, 150/90MM, SMARTFORMED ALLOY, BB30, ISCG03, X-12, 1.5 SI HEADTUBE
FORK	FOX 32 FLOAT CTD O/C, EVOLUTION, 150MM, 15QR THRU AXLE, 1.5"
REAR SHOCK	FOX DYAD RT2 DUAL SHOCK, 150/90MM, W/REMOTE LEVER
RIMS	WTB ST I23 TCS, 32 HOLE, TUBELESS READY
HUBS	FORMULA DC71, 15MM FRONT, SUN RINGLE DIRTY FLEA, 142 X 12MM REAR
SPOKES	DT SWISS CHAMPION
TIRES	SCHWALBE HANS DAMPF, 26 X 2.35", FOLDING
PEDALS	N/A
CRANKS	SRAM S1000, BB30, 36/22 W/GUARD
BOTTOM BRACKET	SRAM BB30
CHAIN	KMC X10, 10-SPEED
REAR COGS	SHIMANO HG62-10, 11-36, 10-SPEED
FRONT DERAILLEUR	SRAM X7, DIRECT MOUNT
REAR DERAILLEUR	SHIMANO XT, SHADOW DESIGN, 10-SPEED
SHIFTERS	SHIMANO SLX
HANDLEBAR	CANNONDALE C2 RISER, 660X20MM, 2014 ALLOY
GRIPS	CANNONDALE DUAL LOCKING GRIPS
STEM	CANNONDALE C2, 1.5", 31.8
HEADSET	TANGE SEIKI, 1.5", INTEGRATED
BRAKES	MAGURA MT2 W/BAT HYDRAULIC DISC, 180/180MM
BRAKE LEVERS	MAGURA MT2 HYDRAULIC DISC
SADDLE	CANNONDALE WOMEN'S ERGO XC, CRO-MO RAILS
SEATPOST	CANNONDALE C2, 31.6 X 350MM
SIZES	P, S, M
COLOR (CODE)	JET BLACK, MATTE (BBQ)
EXTRAS	HIGH PRESSURE SHOCK PUMP, SYNTACE X-12 142MM REAR AXLE

	QUICK CX 3
PRODUCT CODE	C130X3
FRAME	QUICK CX, OPTIMIZED 6061 ALLOY, SAVE, 1.5" HEAD TUBE
FORK	RST NEON PRO CUSTOM 1.5" TREKKING ML LOCKOUT 50MM
REAR SHOCK	MADDUX TC 5.0, DOUBLE WALL, EYELET, MACHINED SIDEWALL, 32 HOLE
RIMS	SHIMANO ALIVIO M430
HUBS	STAINLESS STEEL XD BLACK, 15G
SPOKES	SCHWALBE SAMMY SLICK, 700X35C
TIRES	CANNONDALE URBAN 6POINT3 ALLOY PLATFORM
PEDALS	SHIMANO ACERA M391, 48/36/26
CRANKS	SHIMANO ACERA
BOTTOM BRACKET	KMC Z99, 9-SPEED
CHAIN	SUNRACE CSM96, 11-32, 9-SPEED
REAR COGS	SHIMANO ACERA, 31.8 CLAMP
FRONT DERAILLEUR	SHIMANO DEORE
REAR DERAILLEUR	SHIMANO ACERA
SHIFTERS	CANNONDALE C3, BUTTED 6061 ALLOY, 5MM RISE, 600MM
HANDLEBAR	CANNONDALE ERGO PERFORMANCE, LOCK ON
GRIPS	CANNONDALE C3, 1.5", 3-D FORGED, 31.8, 7 DEG.
STEM	TANGE CUSTOM 1.5"
HEADSET	TEKTRO 855 V-BRAKE
BRAKES	CANNONDALE C3
BRAKE LEVERS	CANNONDALE QUICK CX ERGO
SADDLE	CANNONDALE C4, ALLOY, 31.6 X 350MM
SEATPOST	48, 52, 56, 60
SIZES	JET BLACK, MATTE (BBQ)
COLOR (CODE)	BRUSHED ALUMINUM, GLOSS (RAW)

	TESORO 2
PRODUCT CODE	C12TS3
FRAME	TESORO SI, OPTIMIZED 6061 ALLOY, SAVE
FORK	CANNONDALE SI CARBON BLADES
RIMS	CANNONDALE TC05, DOUBLE WALL, EYELETED, 32 HOLE
HUBS	SHIMANO DEORE
SPOKES	STAINLESS STEEL XD BLACK W/ RED NIPPLES, 15G
TIRES	SCHWALBE MARATHON SUPREME, 700X35C
PEDALS	CANNONDALE URBAN 6POINT3 ALLOY
CRANKS	SHIMANO DEORE
BOTTOM BRACKET	SHIMANO OCTALINK
CHAIN	SHIMANO HG53, 9-SPEED
REAR COGS	SHIMANO DEORE HG50, 11-32, 9-SPEED
FRONT DERAILLEUR	SHIMANO SLX
REAR DERAILLEUR	SHIMANO SLX
SHIFTERS	SHIMANO DEORE
HANDLEBAR	CANNONDALE TREKKING BLACK
GRIPS	CANNONDALE ERGO PERFORMANCE, LOCK ON
STEM	CANNONDALE UP C3 ADJUSTABLE BLACK
HEADSET	TANGE SEMI-INTEGRATED
BRAKES	AVID SINGLE DIGIT 5
BRAKE LEVERS	AVID FR5
SADDLE	CANNONDALE QUICK CX
SEATPOST	CANNONDALE C3, 6061 ALLOY, 2 BOLT, 31.6 X 350MM
SIZES	48, 52, 56, 60
COLOR (CODE)	CHARCOAL GRAY, GLOSS (GRY)
EXTRAS	TUBUS RACK, BUSCH & MULLER LIGHTS, CURANA FENDERS & CHAINCASE

	LEXI 2
PRODUCT CODE	C13VLW2
FRAME	LEXI, 120MM, SMARTFORMED ALLOY, BB30, 1.5" SI HEAD TUBE
FORK	ROCKSHOX RECON GOLD TK, 120MM, SOLO AIR, LOCKOUT, REBOUND, 1.5"
REAR SHOCK	ROCKSHOX MONARCH RL
RIMS	MADDUX DC3.0, DOUBLE WALL W/EYELET, 32 HOLE
HUBS	FORMULA DC20 SL FRONT, DC22 SL 135X9MM REAR
SPOKES	DT SWISS COMPETITION
TIRES	SCHWALBE RACING RALPH PERFORMANCE, 26X2.1, FOLDING
PEDALS	FPD PLATFORM, ALLOY
CRANKS	SRAM S1000, BB30, 38/24
BOTTOM BRACKET	SRAM BB30
CHAIN	KMC X10, 10-SPEED
REAR COGS	SRAM PG 1030, 11-36, 10-SPEED
FRONT DERAILLEUR	SRAM X7, 34.9 HIGH CLAMP
REAR DERAILLEUR	SRAM X9 CARBON
SHIFTERS	SRAM X7, W/MATCHMAKER
HANDLEBAR	CANNONDALE C3 RISER, 640X20, 2014 ALLOY
GRIPS	CANNONDALE DUAL LOCKING GRIPS
STEM	CANNONDALE C3, 1.5", 31.8
HEADSET	TANGE SEIKI 1.5", INTEGRATED
BRAKES	AVID ELIXIR 3, 180/160MM
BRAKE LEVERS	AVID ELIXIR 3
SADDLE	CANNONDALE WOMEN'S ERGO XC
SEATPOST	CANNONDALE C3, 31.6X350MM
SIZES	P,S,M
COLOR (CODE)	MAGNESIUM WHITE, GLOSS (WHT)
EXTRAS	N/A

WOMEN'S SPECIFICATIONS

TRAIL SL WOMEN'S 2	
PRODUCT CODE	C13FW92
FRAME	TRAIL SL 29"ER WOMEN'S, OPTIMIZED 6061 ALLOY, SAVE, 1.5" HEADTUBE
FORK	ROCKSHOX RECON SILVER TK 29, 80MM, SOLO AIR, LOCKOUT, REBOUND, 1.5"
REAR SHOCK	N/A
RIMS	MADDUX DC3.0 29"ER, DOUBLE WALL W/EYELET, 32 HOLE
HUBS	FÓRMULA CDH20 FRONT, CDH22 REAR
SPOKES	STAINLESS STEEL, BLACK, 15G
TIRES	KENDA SMALL BLOCK 8, 29X2.1"
PEDALS	FPD PLATFORM
CRANKS	SHIMANO FC-M391-8, OCTALINK, 44/32/22
BOTTOM BRACKET	SHIMANO BB-ES25, OCTALINK
CHAIN	SHIMANO HG53, 9-SPEED
REAR COGS	SHIMANO HG51-9, 11-34, 9-SPEED
FRONT DERAILLEUR	SHIMANO ALIVIO, 31.8 CLAMP
REAR DERAILLEUR	SHIMANO DEORE, SHADOW DESIGN, 9-SPEED
SHIFTERS	SHIMANO ALIVIO W/GEAR DISPLAY
HANDLEBAR	CANNONDALE C3 FLAT, 660MM, 12 DEG SWEEP, 6061 DOUBLE-BUTTED ALLOY
GRIPS	CANNONDALE DUAL-DENSITY GRIPS
STEM	CANNONDALE C4, 1.5", 31.8, 7 DEGREE
HEADSET	TANGE CUSTOM 1.5"
BRAKES	CANNONDALE HELIX 6 HYDRAULIC DISC, 160/160MM
BRAKE LEVERS	CANNONDALE HELIX 6
SADDLE	CANNONDALE WOMEN'S ERGO XC
SEATPOST	CANNONDALE C4, 27.2X350MM
SIZES	S,M,T
COLOR (CODE)	MAGNESIUM WHITE, GLOSS (WHT)

SUPERSIX EVO WOMEN'S ULTEGRA DI2	
PRODUCT CODE	C13RW5C
FRAME	SUPERSIX EVO WOMEN'S, FULL CARBON, DI2 SPECIFIC, SPEED SAVE, PRESSFIT BB30
FORK	SUPERSIX EVO, SPEED SAVE, FULL CARBON, 1-1/8" TO 1-1/4" STEERER
REAR SHOCK	N/A
RIMS	SHIMANO ULTEGRA 6700 TUBELESS
HUBS	SHIMANO ULTEGRA 6700
SPOKES	SHIMANO ULTEGRA 6700
TIRES	SCHWALBE ULTREMO TUBELESS 700X23C
PEDALS	N/A
CRANKS	CANNONDALE HOLLOWGRAM SI, FSA CHAINRINGS, 50/34
BOTTOM BRACKET	SRAM PRESSFIT BB30
CHAIN	SHIMANO ULTEGRA 6700
REAR COGS	SHIMANO ULTEGRA 6700, 11-28, 10-SPEED
FRONT DERAILLEUR	SHIMANO ULTEGRA DI2 6770
REAR DERAILLEUR	SHIMANO ULTEGRA DI2 6770
SHIFTERS	SHIMANO ULTEGRA DI2 6770 W/ REACH ADJUST SHIMS
HANDLEBAR	CANNONDALE C1 WOMEN'S COMPACT WING, HYDROFORMED 7050 ALLOY
GRIPS	CANNONDALE BAR TAPE W/GEL, 2.5MM
STEM	CANNONDALE C1 31.8MM 6 DEG.
HEADSET	SUPERSIX EVO, 1-1/4" LOWER BEARING, 25MM CARBON TOP COVER (W/ 5MM ALLOY HIDDEN TOP COVER)
BRAKES	SHIMANO ULTEGRA 6700
BRAKE LEVERS	SHIMANO ULTEGRA DI2
SADDLE	FI'ZI:K ARIONE DONNA, W/ MG RAILS
SEATPOST	CANNONDALE C1, LIGHTWEIGHT ALLOY 27.2X250MM
SIZES	44, 48, 51, 54, 56
COLOR (CODE)	EXPOSED UNI-DIRECTIONAL CARBON W/ HOLLYWOOD SILVER, GLOSS (BLK)

SLICE WOMEN'S 3 ULTEGRA	
PRODUCT CODE	C13RW3C
FRAME	SLICE WOMEN'S, FULL CARBON, AERO SAVE, BB30
FORK	SLICE AERO, FULL CARBON, 1-1/8"
REAR SHOCK	N/A
RIMS	VISION TEAM 30
HUBS	VISION TEAM 30
SPOKES	VISION TEAM 30
TIRES	SCHWALBE LUGANO, 700X23C, FOLDING (VITTORIA RUBINO 650X23C, FOLDING)
PEDALS	N/A
CRANKS	FSA SL-K LIGHT CARBON BB30, 50/34
BOTTOM BRACKET	FSA BB30
CHAIN	SHIMANO ULTEGRA 6700
REAR COGS	SHIMANO ULTEGRA 6700, 11-28, 10-SPEED
FRONT DERAILLEUR	SHIMANO ULTEGRA 6700
REAR DERAILLEUR	SHIMANO ULTEGRA 6700
SHIFTERS	SHIMANO ULTEGRA 6700 W/ REACH ADJUST SHIMS
HANDLEBAR	CANNONDALE C3 BASE BAR, 31.8 W/ FSA TRI MAX TEAM CLIP ON'S
GRIPS	CANNONDALE BAR TAPE W/GEL, 2.5MM
STEM	CANNONDALE C2, 31.8, 6 DEG.
HEADSET	SLICE, SI, 15MM TOP CAP
BRAKES	SHIMANO ULTEGRA 6700
BRAKE LEVERS	SHIMANO ULTEGRA 6700
SADDLE	PROLOGO NAGO EVO TRI40 DEA W/ PROT 2.0 RAILS
SEATPOST	CANNONDALE SLICE CARBON AERO, 2 POSITION
SIZES	47, 51, 54
COLOR (CODE)	CHARCOAL GRAY W/ PORCELAIN BLUE, MATTE (GRY)

TRAIL SL WOMEN'S 3	
PRODUCT CODE	C13FSW3
FRAME	TRAIL SL WOMEN'S, OPTIMIZED 6061 ALLOY, SAVE, 1.5" HEADTUBE
FORK	ROCKSHOX XC 30 TK, 100MM, SIZE SPECIFIC COIL SPRING, LOCKOUT, 1.5"
REAR SHOCK	N/A
RIMS	MADDUX DC3.0, DOUBLE WALL W/EYELET, 28 HOLE
HUBS	CANNONDALE C4 DISC, FRONT AND REAR
SPOKES	STAINLESS STEEL, BLACK, 15G
TIRES	SCHWALBE RAPID ROB, 26X2.1"
PEDALS	FPD PLATFORM
CRANKS	SHIMANO FC-M430-8, 44/32/22
BOTTOM BRACKET	SHIMANO BB-ES25, OCTALINK
CHAIN	SHIMANO HG53, 9-SPEED
REAR COGS	SUNRACE M96, 11-34, 9-SPEED
FRONT DERAILLEUR	SHIMANO ALIVIO, 31.8 CLAMP
REAR DERAILLEUR	SHIMANO DEORE, SHADOW DESIGN, 9-SPEED
SHIFTERS	SHIMANO ALIVIO W/GEAR DISPLAY
HANDLEBAR	CANNONDALE C3, 640X15, 6061 DOUBLE-BUTTED ALLOY
GRIPS	CANNONDALE ALLOY LOCKING GRIPS W/CLOSED END
STEM	CANNONDALE C4, 1.5", 31.8, 7 DEGREE
HEADSET	TANGE CUSTOM 1.5"
BRAKES	SHIMANO BR-M446, 160/160MM
BRAKE LEVERS	SHIMANO BR-M446
SADDLE	CANNONDALE WOMEN'S ERGO XC
SEATPOST	CANNONDALE C3, 27.2X350MM
SIZES	P,S,M,T
COLOR (CODE)	MAGNESIUM WHITE, GLOSS (WHT)

SUPERSIX WOMEN'S 5 105	
PRODUCT CODE	C13RW5SC
FRAME	SUPERSIX WOMEN'S, FULL CARBON, BB30
FORK	SUPERSIX, FULL CARBON, 1-1/8" TO 1.5" TAPERED STEERER, ALLOY DROPOUTS
REAR SHOCK	N/A
RIMS	SHIMANO RS-10
HUBS	SHIMANO RS-10
SPOKES	SHIMANO RS-10
TIRES	SCHWALBE LUGANO, 700X23C, FOLDING
PEDALS	N/A
CRANKS	FSA GOSSAMER PRO, BB30, 50/34
BOTTOM BRACKET	SRAM PRESSFIT BB30
CHAIN	SHIMANO 105 5700
REAR COGS	SHIMANO 105 5700, 11-28, 10-SPEED
FRONT DERAILLEUR	SHIMANO 105 5700
REAR DERAILLEUR	SHIMANO 105 5700
SHIFTERS	SHIMANO 105 5700 W/ REACH ADJUST SHIMS
HANDLEBAR	CANNONDALE C3 WOMEN'S COMPACT WING, BUTTED 6061 ALLOY
GRIPS	CANNONDALE BAR TAPE W/GEL, 2.5MM
STEM	CANNONDALE C3, 31.8, 6 DEG
HEADSET	SUPERSIX, 1.5 LOWER BEARING, 30MM CARBON TOP CAP, W/5MM HIDDEN ALLOY TOP COVER
BRAKES	SHIMANO 105 5700
BRAKE LEVERS	SHIMANO 105 5700
SADDLE	PROLOGO, KAPPA EVO DEA W/ PROT 2.0 RAILS
SEATPOST	CANNONDALE C3, CARBON WRAP, 31.8X300MM
SIZES	44, 48, 51, 54
COLOR (CODE)	EXPOSED UNI-DIRECTIONAL CARBON W/ LIME FROST, GLOSS (BLK)

SYNAPSE CARBON WOMEN'S ULTEGRA	
PRODUCT CODE	C13RW3CT
FRAME	SYNAPSE WOMEN'S, FULL CARBON, SAVE PLUS, BB30
FORK	SYNAPSE, FULL CARBON, SAVE PLUS, 1-1/8"
REAR SHOCK	N/A
RIMS	MAVIC AKSIUM WTS
HUBS	MAVIC AKSIUM WTS
SPOKES	MAVIC AKSIUM WTS
TIRES	MAVIC AKSION, 700X25C, FOLDING
PEDALS	N/A
CRANKS	FSA SL-K LIGHT CARBON BB30, 52/39/30
BOTTOM BRACKET	FSA BB30
CHAIN	SHIMANO ULTEGRA 6700
REAR COGS	SHIMANO ULTEGRA 6700, 11-28, 10-SPEED
FRONT DERAILLEUR	SHIMANO ULTEGRA 6700
REAR DERAILLEUR	SHIMANO ULTEGRA 6700
SHIFTERS	SHIMANO ULTEGRA 6700 W/ REACH ADJUST SHIMS
HANDLEBAR	CANNONDALE C2 WOMEN'S COMPACT WING, BUTTED 2014 ALLOY
GRIPS	CANNONDALE BAR TAPE W/GEL, 3.5MM
STEM	CANNONDALE C2, 31.8, 6 DEG.
HEADSET	SYNAPSE SI, 25MM CARBON TOP CAP
BRAKES	SHIMANO ULTEGRA 6700
BRAKE LEVERS	SHIMANO ULTEGRA 6700
SADDLE	FI'ZI:K VESTA, W/ MG RAILS
SEATPOST	CANNONDALE C2, UD CARBON, 27.2X300MM
SIZES	44, 48, 51, 54
COLOR (CODE)	MAGNESIUM WHITE W/ TANGERINE DREAM, GLOSS (WHT)

TRAIL SL WOMEN'S 4	
PRODUCT CODE	C13FSW4
FRAME	TRAIL SL WOMEN'S, OPTIMIZED 6061 ALLOY, SAVE, 1.5" HEADTUBE
FORK	SR SUNTOUR XCR, 100MM, SIZE SPECIFIC COIL SPRING, LOCKOUT, 1-1/8"
REAR SHOCK	N/A
RIMS	MADDUX DC3.0, DOUBLE WALL W/EYELET, 28 HOLE
HUBS	CANNONDALE C4 DISC, FRONT AND REAR
SPOKES	STAINLESS STEEL, BLACK, 15G
TIRES	SCHWALBE RAPID ROB, 26X2.1"
PEDALS	FPD PLATFORM
CRANKS	SHIMANO FC-M391-8, OCTALINK, 44/32/22
BOTTOM BRACKET	SHIMANO BB-ES25, OCTALINK
CHAIN	SHIMANO HG53, 9-SPEED
REAR COGS	SUNRACE M96, 11-34, 9-SPEED
FRONT DERAILLEUR	SHIMANO ALTUS, 31.8 CLAMP
REAR DERAILLEUR	SHIMANO ALIVIO, 9-SPEED
SHIFTERS	SHIMANO ACERA, W/GEAR DISPLAY
HANDLEBAR	CANNONDALE C3, 640X15, 6061 DOUBLE-BUTTED ALLOY
GRIPS	CANNONDALE ALLOY LOCKING GRIPS W/CLOSED END
STEM	CANNONDALE C4, 1-1/8", 31.8, 7 DEGREE
HEADSET	TANGE REDUCER 1.5 - 1-1/8"
BRAKES	CANNONDALE HELIX 6 HYDRAULIC DISC, 160/160MM
BRAKE LEVERS	CANNONDALE HELIX 6
SADDLE	CANNONDALE WOMEN'S ERGO XC
SEATPOST	CANNONDALE C3, 27.2X350MM
SIZES	P,S,M,T
COLOR (CODE)	NIAGARA BLUE, GLOSS (BLU)

CAAD10 WOMEN'S 3 ULTEGRA	
PRODUCT CODE	C13RW3XC
FRAME	CAAD10 WOMEN'S, SMARTFORMED 6069 ALLOY, SPEED SAVE, BB30
FORK	CAAD10, SPEED SAVE FULL CARBON, 1-1/8" TO 1-1/4" TAPERED STEERER
REAR SHOCK	N/A
RIMS	MAVIC AKSIUM WTS
HUBS	MAVIC AKSIUM WTS
SPOKES	MAVIC AKSIUM WTS
TIRES	MAVIC AKSION, 700X23C, FOLDING
PEDALS	N/A
CRANKS	FSA SL-K LIGHT CARBON BB30, 50/34
BOTTOM BRACKET	FSA BB30
CHAIN	SHIMANO ULTEGRA 6700
REAR COGS	SHIMANO 105 5700, 11-28, 10-SPEED
FRONT DERAILLEUR	SHIMANO ULTEGRA 6700
REAR DERAILLEUR	SHIMANO ULTEGRA 6700
SHIFTERS	SHIMANO ULTEGRA 6700 W/ REACH ADJUST SHIMS
HANDLEBAR	CANNONDALE C3 WOMEN'S COMPACT WING, BUTTED 6061 ALLOY
GRIPS	CANNONDALE BAR TAPE W/GEL, 2.5MM
STEM	CANNONDALE C3, 31.8, 6 DEG
HEADSET	CAAD10, 1-1/4" LOWER BEARING, 25MM TOP CAP
BRAKES	SHIMANO ULTEGRA 6700
BRAKE LEVERS	SHIMANO ULTEGRA 6700
SADDLE	PROLOGO, KAPPA EVO DEA W/ PROT 2.0 RAILS
SEATPOST	CANNONDALE C2, UD CARBON, 27.2X300MM
SIZES	44, 48, 51, 54
COLOR (CODE)	MAGNESIUM WHITE W/ NIAGARA BLUE, GLOSS (WHT)

SYNAPSE CARBON WOMEN'S 5 105	
PRODUCT CODE	C13RW3CT
FRAME	SYNAPSE WOMEN'S, FULL CARBON, SAVE PLUS, BB30
FORK	SYNAPSE, FULL CARBON, SAVE PLUS, 1-1/8"
REAR SHOCK	N/A
RIMS	SHIMANO RS-10
HUBS	SHIMANO RS-10
SPOKES	SHIMANO RS-10
TIRES	SCHWALBE LUGANO, 700X25C, FOLDING
PEDALS	N/A
CRANKS	FSA GOSSAMER PRO, BB30, 50/39/30
BOTTOM BRACKET	FSA BB30
CHAIN	SHIMANO 105 5700
REAR COGS	SHIMANO 105 5700, 11-28, 10-SPEED
FRONT DERAILLEUR	SHIMANO 105 5700
REAR DERAILLEUR	SHIMANO 105 5700
SHIFTERS	SHIMANO 105 5700 W/ REACH ADJUST SHIMS
HANDLEBAR	CANNONDALE C3 WOMEN'S COMPACT WING, BUTTED 6061 ALLOY
GRIPS	CANNONDALE 2.5MM SUEDE W/ GEL BACKING GRIP TAPE
STEM	CANNONDALE C3, 31.8, 6 DEG
HEADSET	SYNAPSE SI, 25MM TOP CAP
BRAKES	SHIMANO 105 5700
BRAKE LEVERS	SHIMANO 105 5700
SADDLE	PROLOGO, KAPPA EVO DEA W/ PROT 2.0 RAILS
SEATPOST	CANNONDALE C3, ALLOY, 27.2X300MM
SIZES	44, 48, 51, 54
COLOR (CODE)	MAGNESIUM WHITE W/ HOLLYWOOD SILVER, GLOSS (WHT)

TRAIL SL WOMEN'S 5	
PRODUCT CODE	C13FSW5
FRAME	TRAIL SL WOMEN'S, OPTIMIZED 6061 ALLOY, SAVE, 1.5" HEADTUBE
FORK	SR SUNTOUR XCM, 100MM, SIZE SPECIFIC COIL SPRING, HYDRAULIC LOCKOUT, 1-1/8"
REAR SHOCK	N/A
RIMS	MADDUX DC3.0, DOUBLE WALL W/EYELET, 28 HOLE
HUBS	CANNONDALE C4 DISC, FRONT AND REAR
SPOKES	STAINLESS STEEL, BLACK, 15G
TIRES	SCHWALBE RAPID ROB, 26X2.1"
PEDALS	FPD PLATFORM
CRANKS	SHIMANO, FC-M311, 44/32/22
BOTTOM BRACKET	TANGE SEIKI SQUARE TAPER
CHAIN	KMC X8, 8-SPEED
REAR COGS	SHIMANO HG31-8, 11-32, 8-SPEED
FRONT DERAILLEUR	SHIMANO ALTUS, 31.8 CLAMP
REAR DERAILLEUR	SHIMANO ACERA, 8-SPEED
SHIFTERS	SHIMANO ALTUS, W/GEAR DISPLAY
HANDLEBAR	CANNONDALE C3, 640X15, 6061 DOUBLE-BUTTED ALLOY
GRIPS	CANNONDALE DUAL-DENSITY GRIPS
STEM	CANNONDALE C4, 1-1/8", 31.8, 7 DEGREE
HEADSET	TANGE REDUCER 1.5 - 1-1/8"
BRAKES	CANNONDALE HELIX 6 HYDRAULIC DISC, 160/160MM
BRAKE LEVERS	CANNONDALE HELIX 6
SADDLE	CANNONDALE WOMEN'S ERGO XC
SEATPOST	CANNONDALE C3, 27.2X350MM
SIZES	P,S,M
COLOR (CODE)	JET BLACK, GLOSS (BLK)

CAAD10 WOMEN'S 5 105	
PRODUCT CODE	C13RW5XC
FRAME	CAAD10 WOMEN'S, SMARTFORMED 6069 ALLOY, SPEED SAVE, BB30
FORK	CAAD10, SPEED SAVE FULL CARBON, 1-1/8" TO 1-1/4" TAPERED STEERER
REAR SHOCK	N/A
RIMS	SHIMANO RS-10
HUBS	SHIMANO RS-10
SPOKES	SHIMANO RS-10
TIRES	SCHWALBE LUGANO, 700X23C, FOLDING
PEDALS	N/A
CRANKS	FSA GOSSAMER PRO, BB30, 50/34
BOTTOM BRACKET	FSA BB30
CHAIN	SHIMANO 105 5700
REAR COGS	SHIMANO 105 5700, 11-28, 10-SPEED
FRONT DERAILLEUR	SHIMANO 105 5700
REAR DERAILLEUR	SHIMANO 105 5700
SHIFTERS	SHIMANO 105 5700 W/ REACH ADJUST SHIMS
HANDLEBAR	CANNONDALE C3 WOMEN'S COMPACT WING, BUTTED 6061 ALLOY
GRIPS	CANNONDALE BAR TAPE W/GEL, 2.5MM
STEM	CANNONDALE C3, 31.8, 6 DEG
HEADSET	CAAD10, 1-1/4" LOWER BEARING, 25MM TOP CAP
BRAKES	SHIMANO 105 5700
BRAKE LEVERS	SHIMANO 105 5700
SADDLE	PROLOGO, KAPPA EVO DEA W/ PROT 2.0 RAILS
SEATPOST	CANNONDALE C3, ALLOY, 27.2X300MM
SIZES	44, 48, 51, 54
COLOR (CODE)	MAGNESIUM WHITE W/ LIME FROST, GLOSS (WHT)

SY	
----	--

ROAD

SUPERSIX EVO & SUPERSIX

SPECIFICATIONS	48	50	52	54	56	58	60	63
A HORIZONTAL TOP TUBE LENGTH (CM)	51	52	53.5	54.5	56	57.5	59	60
B MEASURED SIZE (CM)*	46	48	50	52	54	56	58	61
C SEAT TUBE ANGLE (DEGREES)	74.5°	74.5°	74°	73.5°	73.5°	73°	72.5°	72°
D HEAD TUBE ANGLE (DEGREES)	71.5°	72.0°	72.5°	73°	73°	73.5°	73.5°	73.5°
E CHAINSTAY LENGTH (CM)	40.5	40.5	40.5	40.5	40.5	40.5	40.8	40.8
F FORK RAKE (CM)	4.5	4.5	4.5	4.5	4.5	4.5	4.5	4.5
G BOTTOM BRACKET HEIGHT (CM)	26.5	26.5	26.5	26.8	26.8	27	27	27
H WHEELBASE (CM)	96.2	96.7	97.3	97.5	99	99.6	100.8	101.1
I TRAIL (CM)	6.5	6.2	5.9	5.6	5.6	5.3	5.3	5.3
J STANDOVER AT TOP TUBE MIDPOINT (CM)	74.2	75.5	76.7	78.8	80.4	82.5	84.3	86.9
K BOTTOM BRACKET DROP (CM)	7.2	7.2	7.2	6.9	6.9	6.7	6.7	6.7
L FRONT CENTER DISTANCE (CM)	56.3	56.9	57.5	57.6	59.1	59.7	60.6	60.9
M HEAD TUBE LENGTH (CM)	11	11.5	12	14	15.5	17.5	19.5**	22
N STACK (CM)	51.3	51.9	52.6	54.4	55.8	57.7	59.6***	62
O REACH (CM)	36.8	37.6	38.4	38.4	39.5	39.9	40.2	39.9

* THE MEASURED SIZE IS FROM THE CENTER OF THE BOTTOM BRACKET TO THE TOP OF THE TOP TUBE, MEASURED ALONG THE SEAT TUBE AXIS.
 ** SIZE 60 EVO HAS A HEAD TUBE LENGTH OF 19.5 WHILE FOR SUPER SIX THE LENGTH IS 19
 *** SIZE 60 EVO HAS A STACK OF 59.6 WHILE FOR SUPER SIX THE STACK IS 59.3

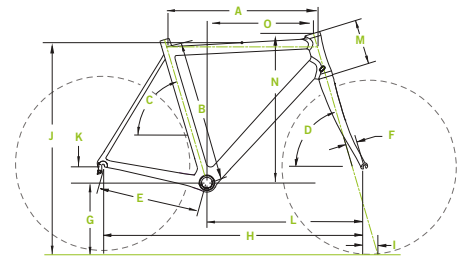

CAAD10

SPECIFICATIONS	48	50	52	54	56	58	60	63
A HORIZONTAL TOP TUBE LENGTH (CM)	51.5	52.5	53.5	54.5	56.0	57.5	59.0	60.0
B MEASURED SIZE (CM)*	46	48	50	52	54	56	58	61
C SEAT TUBE ANGLE (DEGREES)	74.5°	74.5°	74°	73.5°	73.5°	73°	72.5°	72°
D HEAD TUBE ANGLE (DEGREES)	72°	72.5°	73°	73°	73°	73.5°	73.5°	73.5°
E CHAINSTAY LENGTH (CM)	40.5	40.5	40.8	40.8	40.8	40.8	40.8	40.8
F FORK RAKE (CM)	5	5	5	5	4.5	4.5	4.5	4.5
G BOTTOM BRACKET HEIGHT (CM)	26.5	26.5	26.5	26.8	26.8	27.0	27.0	27.0
H WHEELBASE (CM)	96.5	97.2	97.7	97.8	99.3	99.9	100.1	101.3
I TRAIL (CM)	6.2	5.9	5.6	5.6	5.6	5.3	5.3	5.3
J STANDOVER AT TOP TUBE MIDPOINT (CM)	74	75.3	76.5	78.5	80.1	82.2	83.8	86.6
K BOTTOM BRACKET DROP (CM)	7.2	7.2	7.2	6.9	6.9	6.7	6.7	6.7
L FRONT CENTER DISTANCE (CM)	57	57.7	57.9	58.0	59.7	60.1	61.0	61.4
M HEAD TUBE LENGTH (CM)	11	11.5	12.0	14.0	15.5	17.5	19.0	22.0
N STACK (CM)	51.7	52.3	52.9	54.6	56.0	57.9	59.3	62.2
O REACH (CM)	36.8	37.8	38.2	38.3	39.4	39.9	40.4	39.9

CAAD8

SPECIFICATIONS	48	51	54	56	58	61
A HORIZONTAL TOP TUBE LENGTH (CM)	51	53	54.5	56	57.5	59.5
B MEASURED SIZE (CM)*	46	49	52	54	56	59
C SEAT TUBE ANGLE (DEGREES)	75°	74.5°	73.5°	73.5°	73°	72.5°
D HEAD TUBE ANGLE (DEGREES)	72°	72.5°	73°	73°	73.5°	73.5°
E CHAINSTAY LENGTH (CM)	40.8	40.8	40.8	40.8	40.8	40.8
F FORK RAKE (CM)	5	5	4.5	4.5	4.5	4.5
G BOTTOM BRACKET HEIGHT (CM)	26.5	26.5	26.8	26.8	27	27
H WHEELBASE (CM)	96.6	97.9	97.8	99.3	100	101.4
I TRAIL (CM)	5.6	5.3	5.5	5.5	5.2	5.2
J STANDOVER AT TOP TUBE MIDPOINT (CM)	74.4	76.6	78.9	80.6	82.6	85.4
K BOTTOM BRACKET DROP (CM)	7.2	7.2	6.9	6.9	6.7	6.7
L FRONT CENTER DISTANCE (CM)	56.4	57.8	57.6	59.1	59.7	61.1
M HEAD TUBE LENGTH (CM)	12.5	14	15.5	17	19	22
N STACK (CM)	52.8	54.4	55.8	57.3	59.2	62
O REACH (CM)	36.4	37.7	37.9	39	39.5	40.1

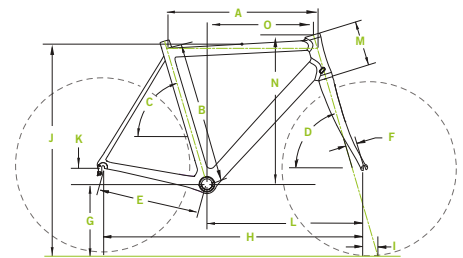

SYNAPSE CARBON

SPECIFICATIONS	48	51	54	56	58	61
A HORIZONTAL TOP TUBE LENGTH (CM)	51	52.5	54	58	60	59
B MEASURED SIZE (CM)*	42	45	48	53	56	58
C SEAT TUBE ANGLE (DEGREES)	74.5°	74°	74°	73°	72.5°	72.5°
D HEAD TUBE ANGLE (DEGREES)	71°	72°	72°	73°	73°	73.5°
E CHAINSTAY LENGTH (CM)	41	41	41	41	41	40.8
F FORK RAKE (CM)	5	5	5	5	5	4.5
G BOTTOM BRACKET HEIGHT (CM)	26.5	26.5	26.8	27.0	27.0	27
H WHEELBASE (CM)	97.0	97.5	98.7	101.1	102.6	100.8
I TRAIL (CM)	6.3	5.7	6.2	5.6	5.6	5.3
J STANDOVER AT TOP TUBE MIDPOINT (CM)	72.1	74.4	77.1	81.1	83.4	84.3
K BOTTOM BRACKET DROP (CM)	7.2	7.2	6.9	6.7	6.7	6.7
L FRONT CENTER DISTANCE (CM)	57.1	57.6	58.7	61.0	62.5	60.6
M HEAD TUBE LENGTH (CM)	13	14.5	16.5	20	22	19.5**
N STACK (CM)	53.0	54.8	56.6	60.1	62.0	59.6***
O REACH (CM)	35.5	36.3	37.4	39.6	40.5	40.2

SYNAPSE ALLOY

SPECIFICATIONS	48	51	54	56	58	61
A HORIZONTAL TOP TUBE LENGTH (CM)	51	52.5	54	56	58	60
B MEASURED SIZE (CM)*	44	47	50	53	55	58
C SEAT TUBE ANGLE (DEGREES)	74.5°	74°	74°	73.5°	73°	72.5°
D HEAD TUBE ANGLE (DEGREES)	70.5°	72°	72°	72.5°	73°	73°
E CHAINSTAY LENGTH (CM)	41.5	41.5	41.5	41.5	41.5	41.5
F FORK RAKE (CM)	5	5	5	5	5	5
G BOTTOM BRACKET HEIGHT (CM)	26.5	26.5	26.8	26.8	27.0	27.0
H WHEELBASE (CM)	97.9	98.0	99.8	100.9	102.1	103.6
I TRAIL (CM)	6.6	5.7	5.7	5.4	5.1	5.1
J STANDOVER AT TOP TUBE MIDPOINT (CM)	73.2	75.6	78.1	80.2	82.2	84.5
K BOTTOM BRACKET DROP (CM)	7.2	7.2	6.9	6.9	6.7	6.7
L FRONT CENTER DISTANCE (CM)	57.5	57.6	59.3	60.4	61.5	63.0
M HEAD TUBE LENGTH (CM)	13	14.5	16.5	18	20	22
N STACK (CM)	52.9	54.8	56.4	58.0	59.9	61.9
O REACH (CM)	35.5	36.4	37.5	38.7	39.7	40.6

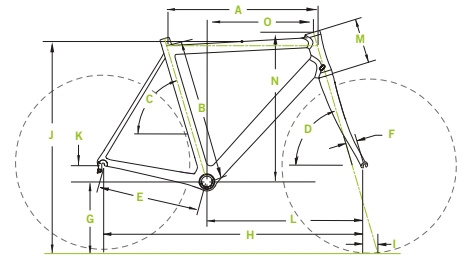

ROAD

SUPERX HI-MOD

SPECIFICATIONS	44	48	51	54	56	58
A HORIZONTAL TOP TUBE LENGTH (CM)	51	52	54	55	57	59
B MEASURED SIZE (CM)*	44	48	52	54	56	58
C SEAT TUBE ANGLE (DEGREES)	75°	74°	73.5°	73.5°	73°	73°
D HEAD TUBE ANGLE (DEGREES)	69°	69.5°	71.5°	72°	72.5°	72.5°
E CHAINSTAY LENGTH (CM)	43	43	43	43	43	43
F FORK RAKE (CM)	4.5	4.5	4.5	4.5	4.5	4.5
G BOTTOM BRACKET HEIGHT (CM)	28.1	28.1	28.1	28.1	28.1	28.1
H WHEELBASE (CM)	101.7	101.4	101.1	101.7	102.6	104.7
I TRAIL (CM)	8.5	8.4	7.0	6.7	6.4	6.4
J STANDOVER AT TOP TUBE MIDPOINT (CM)	74.9	77.0	80.4	82.2	83.6	85.5
K BOTTOM BRACKET DROP (CM)	6.7	6.7	6.7	6.7	6.7	6.7
L FRONT CENTER DISTANCE (CM)	59.6	59.3	59.0	59.6	60.5	62.6
M HEAD TUBE LENGTH (CM)	10	11	13.5	15	16	18
N STACK (CM)	51.8	52.9	56.0	57.6	58.8	60.7
O REACH (CM)	37.1	36.8	37.4	37.9	39.0	40.5

CAADX

SPECIFICATIONS	44	48	51	54	56	58	61
A HORIZONTAL TOP TUBE LENGTH (CM)	51.5	52.5	53.5	54.5	56	57.5	59
B MEASURED SIZE (CM)*	44	47	50	53	55	57	60
C SEAT TUBE ANGLE (DEGREES)	75°	74.5°	74°	73.5°	73.0°	73.0°	72.5°
D HEAD TUBE ANGLE (DEGREES)	69.5°	70.5°	71°	72°	72.5°	72.5°	72.5°
E CHAINSTAY LENGTH (CM)	43.2	43.2	43.2	43.2	43.2	43.2	43.2
F FORK RAKE (CM)	4.5	4.5	4.5	4.5	4.5	4.5	4.5
G BOTTOM BRACKET HEIGHT (CM)	26.7	26.7	26.7	26.7	26.7	26.7	26.7
H WHEELBASE (CM)	101	101.1	101.4	101.2	101.8	101.8	101.8
I TRAIL (CM)	7.7	7.1	6.7	6.1	5.8	5.8	5.8
J STANDOVER AT TOP TUBE MIDPOINT (CM)	73.9	76.2	78.5	80.7	82	84	86
K BOTTOM BRACKET DROP (CM)	6.7	6.7	6.7	6.7	6.7	6.7	6.7
L FRONT CENTER DISTANCE (CM)	58.7	58.8	59.1	58.9	59.5	61	62
M HEAD TUBE LENGTH (CM)	12	13	14.5	15.5	16	18	20
N STACK (CM)	51.2	52.5	54.1	55.4	56	58	60
O REACH (CM)	36.9	37.4	37.6	37.9	38.8	39.7	40.1

* THE MEASURED SIZE IS FROM THE CENTER OF THE BOTTOM BRACKET TO THE TOP OF THE TOP TUBE, MEASURED ALONG THE SEAT TUBE AXIS.

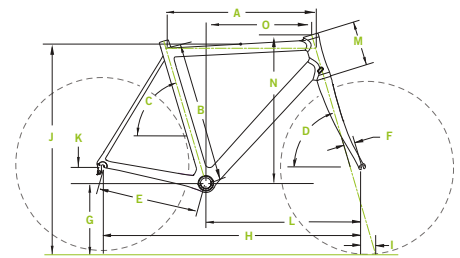

SLICE RS

SPECIFICATIONS	50	52	54	56	58
A HORIZONTAL TOP TUBE LENGTH (CM)	50.4	51.9	53.4	54.9	56.4
B MEASURED SIZE (CM)*	50.0	51.0	53.0	55.0	57.0
C SEAT TUBE ANGLE (DEGREES)	75.0°	75.0°	75.0°	75.0°	75.0°
D HEAD TUBE ANGLE (DEGREES)	71.5°	71.5°	71.5°	71.5°	71.5°
E CHAINSTAY LENGTH (CM)	40.5	40.5	40.5	40.5	40.5
F FORK RAKE (CM)	4.5	4.5	4.5	4.5	4.5
G BOTTOM BRACKET HEIGHT (CM)	26.5	26.5	26.5	26.5	26.5
H WHEELBASE (CM)	96.2	97.8	99.4	101.0	102.7
I TRAIL (CM)	6.5	6.5	6.5	6.5	6.5
J STANDOVER AT TOP TUBE MIDPOINT (CM)	76.5	77.5	79.5	81.5	83.5
K BOTTOM BRACKET DROP (CM)	7.2	7.2	7.2	7.2	7.2
L FRONT CENTER DISTANCE (CM)	56.5	58.0	59.7	61.3	62.9
M HEAD TUBE LENGTH (CM)	7.0	8.0	10.2	12.3	14.4
N STACK (CM)	50.0	51.0	53.0	55.0	57.0
O REACH (CM)	36.9	38.2	39.2	40.1	41.1
P PAD STACK LOWEST (CM/IN)	53.5	54.5	56.5	58.5	60.5
Q PAD STACK HIGHEST (CM/IN)	60.5	61.5	63.5	65.5	67.5
R PAD REACH SHORTEST (CM/IN)	44.1	45.4	46.4	47.3	48.3
S PAD REACH LONGEST (CM/IN)	48.1	49.4	50.4	51.3	52.3

SLICE

SPECIFICATIONS	51	54	56	58	60
A HORIZONTAL TOP TUBE LENGTH (CM)	50.5	53.5	55	56.5	58
B MEASURED SIZE (CM)*	50	51.5	53.5	55.5	57.5
C SEAT TUBE ANGLE (DEGREES)	*VARIABLE	*VARIABLE	*VARIABLE	*VARIABLE	*VARIABLE
D HEAD TUBE ANGLE (DEGREES)	71.5°	71.5°	72°	72°	72°
E CHAINSTAY LENGTH (CM)	40	40	40	40	40
F FORK RAKE (CM)	4.5	4.5	4.5	4.5	4.5
G BOTTOM BRACKET HEIGHT (CM)	26.5	26.5	26.5	26.5	26.5
H WHEELBASE (CM)	95.4	98.5	99.7	101.3	102.6
I TRAIL (CM)	6.5	6.5	6.2	6.2	6.2
J STANDOVER AT TOP TUBE MIDPOINT (CM)	74.9	76.4	78.3	80.2	82.2
K BOTTOM BRACKET DROP (CM)	7.2	7.2	7.2	7.2	7.2
L FRONT CENTER DISTANCE (CM)	56.5	59.6	60.7	62.3	63.9
M HEAD TUBE LENGTH (CM)	9	10.5	12.5	14.5	17
N STACK (CM)	**49.4	50.9	52.9	54.8	57.2
O REACH (CM)	**37.1	39.8	40.7	41.7	42.5

PAD STACK AND REACH ARE MEASURED TO THE CENTER OF THE PAD. SUBTRACT 40MM FOR REAR OF PAD, FSA AERO EXTENSIONS AND ARM RESTS.

* THE SLICE SEAT POST HAS TWO POSITIONS FOR MOUNTING THE SADDLE. A FULL RANGE OF ANGLES FROM 73 TO 79 DEGREES IS ACHIEVABLE DEPENDING ON THE RIDER'S PREFERENCE AND/OR THE EVENT.

**STACK IS MEASURED VERTICALLY FROM THE CENTER OF THE BB TO THE TOP OF THE HEAD TUBE. REACH IS MEASURED HORIZONTALLY FROM THE CENTER OF THE BB TO THE TOP OF THE HEAD TUBE. IF YOU RIDE A 56 ROAD FRAME, YOU SHOULD CHOOSE A SIZE 56 SLICE FRAME.

ALL SIZES HAVE 700C WHEELS.

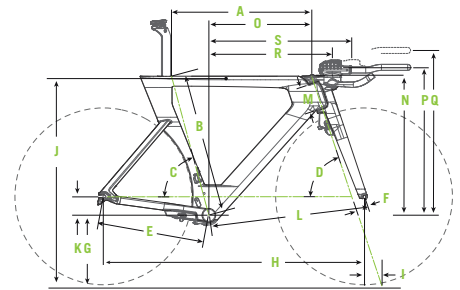

MOUNTAIN

CLAYMORE

SPECIFICATIONS	S	M	L	XL
A SEAT TUBE LENGTH (CM/IN)	39.5/15.6	43.0/16.9	47.0/18.5	51.0/20.1
B TOP TUBE HORIZONTAL (CM/IN)	54.9/21.6	58.2/22.9	61.1/24.1	64.3/25.3
C TOP TUBE ACTUAL (CM/IN)	52.9/20.8	55.6/21.9	58.2/22.9	61.3/24.1
D HEAD TUBE ANGLE HI BB (DEGREES)	66.5°	67.0°	67.0°	67.0°
D HEAD TUBE ANGLE LOW BB (DEGREES)	65.5°	66.0°	66.0°	66.0°
E SEAT TUBE ANGLE EFFECT. (DEGREES)	73.0°	72.6°	72.1°	71.8°
F STANDOVER HI BB (CM/IN)	73.7/29.0	75.6/29.8	78.2/30.8	80.7/31.8
F STANDOVER LOW BB (CM/IN)	72.6/28.6	74.5/29.3	77.1/30.3	79.6/31.3
G HEAD TUBE LENGTH (CM/IN)	11.5/4.5	13.0/5.1	14.0/5.5	15.0/5.9
H WHEELBASE (CM/IN)	110.9/43.7	113.2/44.6	115.7/45.6	118.5/46.7
I FRONT CENTER (CM/IN)	67.6/26.6	69.9/27.5	72.4/28.5	75.2/29.6
J CHAIN STAY LENGTH (CM/IN)	43.3/17.0	43.3/17.0	43.3/17.0	43.3/17.0
K BOTTOM BRACKET DROP HI BB (CM/IN)	2.0/0.8	2.0/0.8	2.0/0.8	2.0/0.8
K BOTTOM BRACKET DROP LOW BB (CM/IN)	0.8/0.3	0.8/0.3	0.8/0.3	0.8/0.3
L BOTTOM BRACKET HEIGHT HI BB (CM/IN)	35.8/14.1	35.8/14.1	35.8/14.1	35.8/14.1
L BOTTOM BRACKET HEIGHT LOW BB (CM/IN)	34.6/13.6	34.6/13.6	34.6/13.6	34.6/13.6
M FORK RAKE (CM/IN)	3.9/1.5	3.9/1.5	3.9/1.5	3.9/1.5
N TRAIL (CM/IN)	10.5/4.1	10.2/4.0	10.2/4.0	10.2/4.0

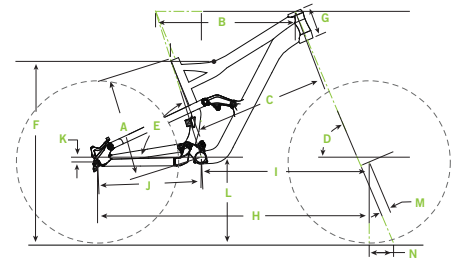

JEKYLL

SPECIFICATIONS	S	M	L	XL
A SEAT TUBE LENGTH (CM/IN)	43.2/17.0	45.7/18.0	48.3/19.0	50.8/20.0
B TOP TUBE HORIZONTAL (CM/IN)	55.6/21.9	58.8/23.1	61.4/24.2	64.2/25.3
C TOP TUBE ACTUAL (CM/IN)	53.4/21.0	56.4/22.2	59.1/23.3	61.8/24.3
D HEAD TUBE ANGLE HI BB (DEGREES)	67.7°	67.8°	67.9°	68.0°
D HEAD TUBE ANGLE LOW BB (DEGREES)	73.6°	73.6°	73.6°	73.5°
E SEAT TUBE ANGLE EFFECT. (DEGREES)	73.6°	73.6°	73.6°	73.6°
F STANDOVER HI BB (CM/IN)	75.2/29.6	75.3/29.6	76.4/30.1	77.7/30.6
F STANDOVER LOW BB (CM/IN)	13.4/5.3	13.4/5.3	13.4/5.3	16.0/6.3
G HEAD TUBE LENGTH (CM/IN)	110.0/43.3	113.1/44.5	115.5/45.5	118.4/46.6
H WHEELBASE (CM/IN)	67.2/26.5	70.3/27.7	72.7/28.6	75.6/29.8
I FRONT CENTER (CM/IN)	42.8/16.9	42.8/16.9	42.8/16.9	42.8/16.9
J CHAIN STAY LENGTH (CM/IN)	1.2/0.5	1.2/0.5	1.2/0.5	1.2/0.5
K BOTTOM BRACKET DROP HI BB (CM/IN)	35.0/13.8	35.0/13.8	35.0/13.8	35.0/13.8
M FORK RAKE (CM/IN)	4.0/1.6	4.0/1.6	4.0/1.6	4.0/1.6
N TRAIL (CM/IN)	9.5/3.8	9.5/3.8	9.4/3.7	9.3/3.7

TRIGGER

S	M	L	XL
43.2/17.0	45.7/18.0	48.3/19.0	50.8/20.0
55.7/21.9	58.6/23.1	61.3/24.1	63.9/25.2
52.9/20.8	55.7/21.9	58.6/23.1	61.2/24.1
68.5°	69.0°	69.0°	69.0°
73.0°	73.0°	73.0°	73.0°
73.0°	73.0°	73.0°	73.0°
72.5/28.5	73.5/28.9	74.0/29.1	75.0/29.5
13.4/5.3	13.4/5.3	13.4/5.3	16.0/6.3
108.6/42.7	110.9/43.6	113.6/44.7	116.4/45.8
66.1/26.0	68.4/26.9	71.1/28.0	73.9/29.1
42.5/16.7	42.5/16.7	42.5/16.7	42.5/16.7
0.0/0.0	0.0/0.0	0.0/0.0	0.0/0.0
33.0/13.0	33.0/13.0	33.0/13.0	33.0/13.0
4.5/1.8	4.5/1.8	4.5/1.8	4.5/1.8
8.2/3.2	7.9/3.1	7.9/3.1	7.9/3.1

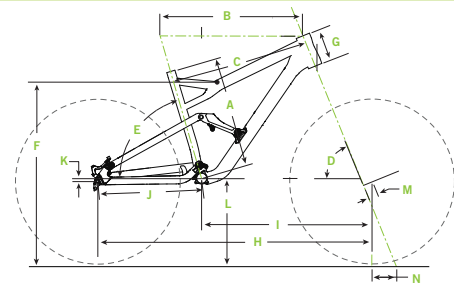

TRIGGER 29ER

SPECIFICATIONS	S	M	L	XL
A SEAT TUBE LENGTH (CM/IN)	42.5/16.7	44.5/17.5	48.5/19.1	50.9/20.0
B TOP TUBE HORIZONTAL (CM/IN)	56.8/22.4	59.6/23.5	62.4/24.6	65.2/25.7
C TOP TUBE ACTUAL (CM/IN)	51.7/20.4	54.0/21.3	56.6/22.3	59.1/23.3
D HEAD TUBE ANGLE HI BB (DEGREES)	69.0°	69.0°	69.0°	69.0°
D HEAD TUBE ANGLE LOW BB (DEGREES)	73.5°	73.5°	73.5°	73.5°
E SEAT TUBE ANGLE EFFECT. (DEGREES)	69.2°	69.2°	69.2°	69.2°
F STANDOVER HI BB (CM/IN)	73.4/28.9	75.4/29.7	76.8/30.2	78.3/30.8
F STANDOVER LOW BB (CM/IN)	9.7/3.8	11.0/4.3	12.2/4.8	13.4/5.3
G HEAD TUBE LENGTH (CM/IN)	111.4/43.9	114.3/45.0	116.6/45.9	119.5/47.0
H WHEELBASE (CM/IN)	66.8/26.3	69.7/27.4	72.0/28.3	74.8/29.4
I FRONT CENTER (CM/IN)	44.8/17.6	44.8/17.6	44.8/17.6	44.8/17.6
J CHAIN STAY LENGTH (CM/IN)	2.8/1.1	2.8/1.1	2.8/1.1	2.8/1.1
K BOTTOM BRACKET DROP HI BB (CM/IN)	34.8/13.7	34.8/13.7	34.8/13.7	34.8/13.7
M FORK RAKE (CM/IN)	5.3/2.1	5.3/2.1	5.3/2.1	5.3/2.1
N TRAIL (CM/IN)	8.8/3.5	8.8/3.5	8.8/3.5	8.8/3.5

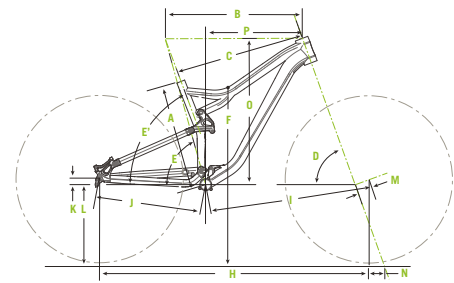

RZ120 / RZ120 XLR

SPECIFICATIONS	S	M	L	XL
A SEAT TUBE LENGTH (CM/IN)	43.2/17.0	45.7/18.0	48.3/19.0	50.9/20.0
B TOP TUBE HORIZONTAL (CM/IN)	56.0/22.0	58.7/23.1	61.3/24.1	64.1/25.2
C TOP TUBE ACTUAL (CM/IN)	53.5/21.1	56.2/22.1	59.1/23.3	61.9/24.4
D HEAD TUBE ANGLE (DEGREES)	69.0°	69.0°	69.0°	69.0°
E SEAT TUBE ANGLE EFFECT. (DEGREES)	73.5°	73.5°	73.5°	73.5°
F STANDOVER (CM/IN)	73.1/28.8	76.0/29.9	76.1/30.0	76.0/29.9
F HEAD TUBE LENGTH (CM/IN)	13.4/5.3	13.4/5.3	13.4/5.3	16.0/6.3
G WHEELBASE (CM/IN)	107.6/42.4	110.3/43.4	113.0/44.5	116.0/45.7
H FRONT CENTER (CM/IN)	65.2/25.7	67.8/26.7	70.5/27.8	73.5/28.9
I CHAIN STAY LENGTH (CM/IN)	42.5/16.7	42.5/16.7	42.5/16.7	42.5/16.7
J BOTTOM BRACKET DROP (CM/IN)	0.0/0.0	0.0/0.0	0.0/0.0	0.0/0.0
K BOTTOM BRACKET HEIGHT (CM/IN)	33.0/13.0	33.0/13.0	33.0/13.0	33.0/13.0
M FORK RAKE (CM/IN)	4.5/1.8	4.5/1.8	4.5/1.8	4.5/1.8
N TRAIL (CM/IN)	7.8/3.1	7.8/3.1	7.8/3.1	7.8/3.1

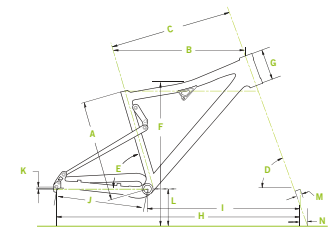

MOUNTAIN

SCALPEL 29ER CARBON

SPECIFICATIONS	S	M	L	XL
A SEAT TUBE LENGTH (CM/IN)	42.0/16.5	44.5/17.5	48.5/19.1	53.5/21.1
B TOP TUBE HORIZONTAL (CM/IN)	56.9/22.4	59.3/23.3	61.7/24.3	64.1/25.2
C TOP TUBE ACTUAL (CM/IN)	53.5/21.1	55.5/21.9	57.8/22.8	60.5/23.8
D HEAD TUBE ANGLE (DEGREES)	70.5°	71.0°	71.2°	71.4°
E SEAT TUBE ANGLE EFFEC. (DEGREES)	73.5°	73.5°	73.5°	73.5°
F STANDOVER (CM/IN)	73.6/29.0	74.7/29.4	75.6/29.8	77.2/30.4
F HEAD TUBE LENGTH (CM/IN)	12.2/4.8	12.2/4.8	12.2/4.8	12.2/4.8
G WHEELBASE (CM/IN)	108.2/42.6	110.0/43.3	112.2/44.2	114.3/45.0
H FRONT CENTER (CM/IN)	64.0/25.2	65.9/25.9	68.0/26.8	70.2/27.6
I CHAIN STAY LENGTH (CM/IN)	44.4/17.5	44.4/17.5	44.4/17.5	44.4/17.5
J BOTTOM BRACKET DROP (CM/IN)	3.8/1.5	3.8/1.5	3.8/1.5	3.8/1.5
K BOTTOM BRACKET HEIGHT (CM/IN)	33.2/13.1	33.2/13.1	33.2/13.1	33.2/13.1
M FORK RAKE (CM/IN)	4.5/1.8	4.5/1.8	4.5/1.8	4.5/1.8
N TRAIL (CM/IN)	8.3/3.3	8.0/3.1	7.8/3.1	7.7/3.0
O STACK (CM/IN)	61.2/24.1	61.4/24.2	61.5/24.2	61.5/24.2
P REACH (CM/IN)	38.8/15.3	41.2/16.2	43.5/17.1	45.9/18.1

SCALPEL 29ER ALLOY

S	M	L	XL
41.1/16.2	43.0/16.9	48.5/19.1	53.5/21.1
56.9/22.4	59.3/23.3	61.7/24.3	64.1/25.2
53.2/20.9	55.3/21.8	57.8/22.8	60.8/23.9
70.5°	71.0°	71.2°	71.4°
73.9°	73.7°	73.5°	73.3°
73.5/28.9	73.5/28.9	75.3/29.6	76.6/30.1
12.2/4.8	12.2/4.8	12.2/4.8	12.2/4.8
108.2/42.6	110.0/43.3	112.2/44.2	114.3/45.0
64.0/25.2	65.9/25.9	68.0/26.8	70.2/27.6
44.4/17.5	44.4/17.5	44.4/17.5	44.4/17.5
3.8/1.5	3.8/1.5	3.8/1.5	3.8/1.5
33.2/13.1	33.2/13.1	33.2/13.1	33.2/13.1
4.5/1.8	4.5/1.8	4.5/1.8	4.5/1.8
8.3/3.3	8.0/3.1	7.8/3.1	7.7/3.0
61.0/24.0	61.2/24.1	61.3/24.1	61.4/24.2
38.9/15.3	41.2/16.2	43.6/17.2	46.0/18.1

SCALPEL

S	M	L	XL
40.5/15.9	43.5/17.1	48.2/19.0	53.2/20.9
55.5/21.9	58.5/23.0	61.5/24.2	64.0/25.2
53.4/21.0	56.2/22.1	59.5/23.4	62.7/24.7
69.3	69.6	69.8	70.0
74.0	74.0	74.0	74.0
75.9/29.9	75.7/29.8	75.4/29.7	75.4/29.7
13.4/5.3	13.4/5.3	13.4/5.3	13.4/5.3
107.4/42.3	110.0/43.3	112.8/44.4	115.1/45.3
65.0/25.6	67.7/26.6	70.4/27.7	72.7/28.6
42.4/16.7	42.4/16.7	42.4/16.7	42.4/16.7
1.2/0.5	1.2/0.5	1.2/0.5	1.2/0.5
31.8/12.5	31.8/12.5	31.8/12.5	31.8/12.5
4.5/1.8	4.5/1.8	4.5/1.8	4.5/1.8
7.7/3.0	7.5/2.9	7.4/2.9	7.2/2.8

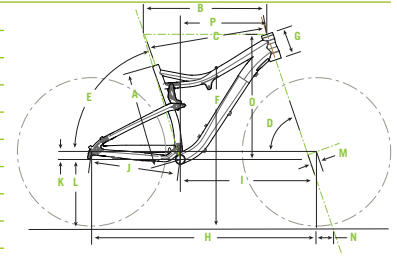

F29ER

SPECIFICATIONS	S	M	L	XL
A SEAT TUBE LENGTH (CM/IN)	39.0/15.4	43.3/17	47.5/18.7	52.5/20.7
B TOP TUBE HORIZONTAL (CM/IN)	56.5/22.2	59.3/23.3	62.2/24.5	64.1/25.2
C TOP TUBE ACTUAL (CM/IN)	56.4/22.2	57.8/22.8	59.7/23.5	61.2/24.1
D HEAD TUBE ANGLE (DEGREES)	71.0°	71.0°	71.0°	71.5°
E SEAT TUBE ANGLE EFFEC. (DEGREES)	73.5°	73.5°	73.0°	72.5°
F STANDOVER (CM/IN)	78.8/31	80.9/31.9	82.9/32.6	85.3/33.6
F HEAD TUBE LENGTH (CM/IN)	13.4/5.3	13.4/5.3	13.4/5.3	13.4/5.3
G WHEELBASE (CM/IN)	106.0/41.7	108.8/42.8	111.1/43.7	111.8/44
H FRONT CENTER (CM/IN)	62.4/24.6	65.2/25.7	67.5/26.6	68.2/26.9
I CHAIN STAY LENGTH (CM/IN)	44.4/17.5	44.4/17.5	44.4/17.5	44.4/17.5
J BOTTOM BRACKET DROP (CM/IN)	6.5/2.6	6.5/2.6	6.5/2.6	6.5/2.6
K BOTTOM BRACKET HEIGHT (CM/IN)	30.5/12	30.5/12	30.5/12	30.5/12
M FORK RAKE (CM/IN)	4.5/1.8	4.5/1.8	4.5/1.8	4.5/1.8
N TRAIL (CM/IN)	8.0/3.1	8.0/3.1	8.0/3.1	7.6/3
O STACK (CM/IN)	64.1/25.2	64.1/25.2	64.1/25.2	64.3/25.3
P REACH (CM/IN)	37.5/14.8	40.3/15.9	42.6/16.8	43.8/17.2

S	M	L	XL
38.0/15	43.3/17	47.5/18.7	52.5/20.7
55.0/21.7	58.5/23	61.4/24.2	62.9/24.8
53.8/21.2	56.3/22.2	58.9/23.2	60.8/23.9
70.0°	70.0°	70.0°	70.0°
73.5°	73.5°	73.5°	73.5°
74.4/29.3	74.4/29.3	74.4/29.3	74.4/29.3
13.4/5.3	13.4/5.3	13.4/5.3	13.4/5.3
104.9/41.3	108.4/42.7	110.8/43.6	111.7/44
62.7/24.7	66.2/26.1	68.6/27	69.5/27.4
42.4/16.7	42.4/16.7	42.4/16.7	42.4/16.7
3.0/1.2	3.0/1.2	3.0/1.2	3.0/1.2
29.5/11.6	29.5/11.6	29.5/11.6	29.5/11.6
4.5/1.8	4.5/1.8	4.5/1.8	4.5/1.8
7.0/2.8	7.0/2.8	7.0/2.8	7.0/2.8

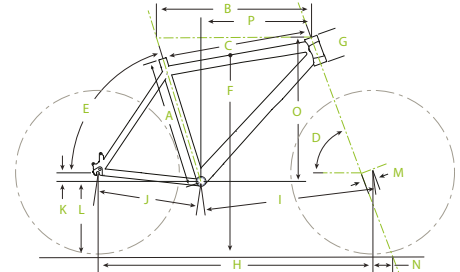

TRAIL SL 29ER

SPECIFICATIONS	S	M	L	XL	JUMBO
A SEAT TUBE LENGTH (CM/IN)	38.0/15.0	43.3/17.0	47.5/18.7	52.5/20.7	57.0/22.4
B TOP TUBE HORIZONTAL (CM/IN)	55.0/21.7	59.4/23.4	62.3/24.5	64.0/25.2	65.0/25.6
C TOP TUBE ACTUAL (CM/IN)	56.1/22.1	60.3/23.7	62.9/24.8	64.4/25.4	65.2/25.7
D HEAD TUBE ANGLE (DEGREES)	71.0°	71.0°	71.0°	71.0°	71.5°
E SEAT TUBE ANGLE EFFEC. (DEGREES)	73.5°	73.5°	73.0°	72.5°	72.5°
E SEAT TUBE ANGLE ACTUAL	73.5°	73.5°	73.0°	72.5°	72.5°
F STANDOVER (CM/IN)	76.3/30.0	79.4/31.3	81.9/32.2	84.9/33.4	87.8/34.6
G HEAD TUBE LENGTH (CM/IN)	9.0/3.5	10.2/4.0	11.4/4.5	12.7/5.0	14.0/5.5
H WHEELBASE (CM/IN)	104.3/41.1	108.8/42.8	111.1/43.7	112.3/44.2	112.7/44.4
I FRONT CENTER (CM/IN)	60.7/23.9	65.2/25.7	67.5/26.6	68.7/27.0	69.1/27.2
J CHAIN STAY LENGTH (CM/IN)	44.4/17.5	44.4/17.5	44.4/17.5	44.4/17.5	44.4/17.5
K BOTTOM BRACKET DROP (CM/IN)	6.5/2.6	6.5/2.6	6.5/2.6	6.5/2.6	6.5/2.6
L BOTTOM BRACKET HEIGHT (CM/IN)	30.5/12.0	30.5/12.0	30.5/12.0	30.5/12.0	30.5/12.0
M FORK RAKE (CM/IN)	4.5/1.8	4.5/1.8	4.5/1.8	4.5/1.8	4.5/1.8
N TRAIL (CM/IN)	8.0/3.1	8.0/3.1	8.0/3.1	8.0/3.1	7.6/3.0
O STACK (CM/IN)	59.8/23.5	61.0/24.0	62.2/24.5	63.4/25.0	64.8/25.5
P REACH (CM/IN)	37.3/14.7	41.3/16.3	43.3/17.0	44.0/17.3	44.6/17.6

TRAIL SL

S	M	L	XL	JUMBO
38.0/15.0	43.3/17.0	47.5/18.7	52.5/20.7	57.0/22.4
55.0/21.7	58.4/23.0	61.4/24.2	62.9/24.8	63.7/25.1
56.4/22.2	59.5/23.4	62.2/24.5	63.4/25.0	64.0/25.2
70.0°	70.0°	70.0°	70.0°	70.0°
73.5°	73.5°	73.0°	72.5°	72.5°
73.5°	73.5°	73.0°	72.5°	72.5°
74.5/29.3	77.7/30.6	80.2/31.6	83.2/32.8	85.9/33.8
9.0/3.5	10.2/4.0	11.4/4.5	12.7/5.0	14.0/5.5
104.6/41.2	108.1/42.6	110.6/43.5	111.6/43.9	112.4/44.3
62.4/24.6	65.9/25.9	68.4/26.9	69.4/27.3	70.3/27.7
42.4/16.7	42.4/16.7	42.4/16.7	42.4/16.7	42.4/16.7
3.0/1.2	3.0/1.2	3.0/1.2	3.0/1.2	3.0/1.2
31.0/12.2	31.0/12.2	31.0/12.2	31.0/12.2	31.0/12.2
4.5/1.8	4.5/1.8	4.5/1.8	4.5/1.8	4.5/1.8
7.6/3.0	7.6/3.0	7.6/3.0	7.6/3.0	7.6/3.0
56.4/22.2	57.6/22.7	58.8/23.1	59.9/23.6	61.1/24.1
38.2/15.0	41.3/16.3	43.4/17.1	44.0/17.3	44.4/17.5

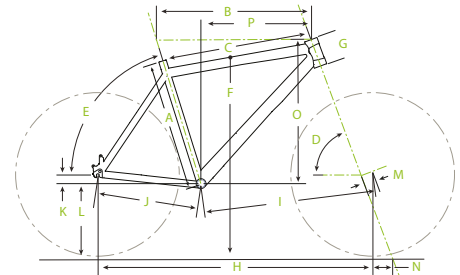

URBAN

BAD BOY HEADSHOK

SPECIFICATIONS	S	M	L	XL
A SEAT TUBE LENGTH (CM/IN)	39/15.4	46/18.1	51/20.1	56/22.0
B TOP TUBE HORIZONTAL (CM)	55	57.5	60	62
C TOP TUBE ACTUAL (CM/IN)	52.1/20.5	54.7/21.5	57.3/22.6	59.7/23.5
D HEAD TUBE ANGLE (DEGREES)	70°	71°	71°	71°
E SEAT TUBE ANGLE (DEGREES)	74.5°	73.5°	73°	72.5°
F STANDOVER HEIGHT (CM)	77	80.4	82.6	84.7
G HEAD TUBE LENGTH (CM)	11.4	11.4	11.4	11.4
H WHEELBASE (CM)	104.4	105.8	108.1	109.8
I FRONT CENTER (CM)	61.4	62.8	65.1	66.8
J CHAIN STAY LENGTH (CM)	43.5	43.5	43.5	43.5
K BOTTOM BRACKET DROP (CM)	5.1	5.1	5.1	5.1
L BOTTOM BRACKET HEIGHT (CM)	29.5	29.5	29.5	29.5
M FORK RAKE (CM)	4.5	4.5	4.5	4.5
N TRAIL (CM)	7.8	7.2	7.2	7.2

BAD BOY

S	M	L	XL
39/15.4	46/18.1	51/20.1	56/22.0
55	57.5	60	62
52.1/20.5	54.7/21.5	57.3/22.6	59.7/23.5
70°	71°	71°	71°
74.5°	73.5°	73°	72.5°
73.9	78.2	81.4	84.5
13	15	17	19
104.4	105.8	108.1	109.8
61.4	62.8	65.1	66.8
43.5	43.5	43.5	43.5
5.1	5.1	5.1	5.1
73.9	78.2	81.4	84.5
4.5	4.5	4.5	4.5
7.8	7.2	7.2	7.2

BAD GIRL

S	L
34.0	41.0
74.5°	73.5°
70.0°	71.0°
52.0	55.5
42.4	42.4
4.5	4.5
27.3	27.3
100.9	103.0
7.5	6.9
62.4	70.9
6.6	6.6
59.1	61.1
13.0	17.0
2.6	

HOOLOGAN

ONE SIZE
39/15.4
58.0
54.7/21.5
70°
73°
60
17.1
106
66.2
40
3.6
30.5
4.5
2.6

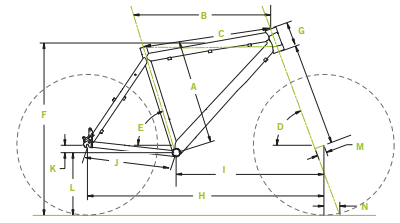

QUICK SPEED CARBON

SPECIFICATIONS	46	51	57
A MEASURED SIZE (CM/IN)*	46	51	57
B SEAT TUBE ANGLE (DEGREES)	74.5°	73°	72.5°
C HEAD TUBE ANGLE (DEGREES)	71.5°	72°	72.5°
D HORIZONTAL TOP TUBE LENGTH (CM)	56	58.5	62
E CHAIN STAY LENGTH (CM)	43	43	43
F FORK RAKE (CM)	5.0	5.0	5.0
G BOTTOM BRACKET HEIGHT (CM)	27.4	27.4	27.4
H WHEELBASE (CM)	103.9	104.8	107.5
I TRAIL (CM)	6.2	5.9	5.6
J STANDOVER HEIGHT (CM)	78.7	82.8	87
K BOTTOM BRACKET DROP (CM)	7.0	7.0	7.0
L FRONT CENTER (CM)	61.9	62.8	65.4
M HEAD TUBE LENGTH (CM)	16	19	24

QUICK SPEED

S	M	L	XL	W42	W46	W52
44.2/17.4	48.2/19.5	52.2/20.5	56.2/22.1	34.0	38.5	43.0
73.5	73	73	72.5	74.0	74.0	73.5
69	70	70.5	71.5	69.0	69.0	69.0
54	56	58	60.5	51.0	52.0	54.0
45	45	45	45	45.0	45.0	45.0
4.5	4.5	4.5	4.5	4.5	4.5	4.5
28.0	28.0	28.0	28.0	27.3	27.3	27.3
105.8	106.2	107.5	108.6	103.3	104.7	105.7
8.5	7.8	7.5	6.9	8.2	8.2	8.2
77.9	80.0	82.4	85.0	66.5	69.5	72.0
6.7	6.7	6.7	6.7	6.6	6.6	6.6
61.6	62.1	63.3	64.5	58.7	60.2	61.2
15	16	17	18	12.0	14.0	16.0

QUICK SPEED WOMENS

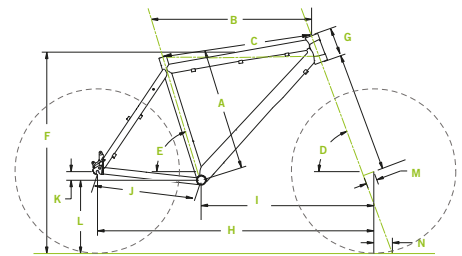

QUICK CX

SPECIFICATIONS	48	52	56	60	W48	W53	W55
A MEASURED SIZE (CM/IN)*	40.2/15.8	44.2/17.4	48.2/19.5	52.2/20.5	44.2/17.4	49.2/19.4	52.2/20.2
B SEAT TUBE ANGLE	74	73.5	73	73	74	73.5	73
C HEAD TUBE ANGLE	69	69	70	70.5	69	70	71
D HORIZONTAL TOP TUBE LENGTH (CM)	54	55	56.5	58	54.5	56	58
E CHAIN STAY LENGTH (CM)	45	45	45	45	45	45	45
F FORK RAKE (CM)	4.5	4.5	4.5	4.5	4.5	4.5	4.5
G BOTTOM BRACKET HEIGHT (CM)	28.0	28.0	28.0	28.0	28.0	28.0	28.0
H WHEELBASE (CM)	104.9	105.8	106.2	107.5	105.7	106.3	107.0
I TRAIL (CM)	8.5	8.5	7.8	7.5	8.5	7.8	7.2
J STANDOVER HEIGHT (CM)	76.1	79.2	82.2	85.0	68.0	68.9	69.9
K BOTTOM BRACKET DROP (CM)	6.7	6.7	6.7	6.7	6.7	6.7	6.7
L FRONT CENTER (CM)	60.7	61.6	62.1	63.3	61.6	62.2	62.8
M HEAD TUBE LENGTH (CM)	14	15	16	17	15	16	17

QUICK CX MIXTE

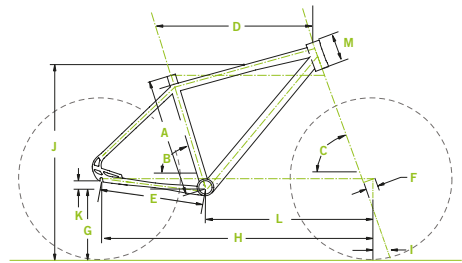

TESORO

SPECIFICATIONS	48	52	56	60	W48	W53	W55
A MEASURED SIZE (CM/IN)*	40.2/15.8	44.2/17.4	48.2/19.5	52.2/20.5	44.2/17.4	49.2/19.4	52.2/20.2
B SEAT TUBE ANGLE	74	73.5	73	73	74	73.5	73
C HEAD TUBE ANGLE	69	69	70	70.5	69	70	71
D HORIZONTAL TOP TUBE LENGTH (CM)	54	55	56.5	58	54.5	56	58
E CHAIN STAY LENGTH (CM)	45	45	45	45	45	45	45
F FORK RAKE (CM)	4.5	4.5	4.5	4.5	4.5	4.5	4.5
G BOTTOM BRACKET HEIGHT (CM)	28.0	28.0	28.0	28.0	28.0	28.0	28.0
H WHEELBASE (CM)	104.9	105.8	106.2	107.5	105.7	106.3	107.0
I TRAIL (CM)	8.5	8.5	7.8	7.5	8.5	7.8	7.2
J STANDOVER HEIGHT (CM)	75.3	77.9	80.0	82.4	67.7	69.7	69.9
K BOTTOM BRACKET DROP (CM)	6.7	6.7	6.7	6.7	6.7	6.7	6.7
L FRONT CENTER (CM)	60.7	61.6	62.1	63.3	61.6	62.2	62.8
M HEAD TUBE LENGTH (CM)	11.4	11.4	11.4	11.4	11.4	11.4	11.4

TESORO MIXTE

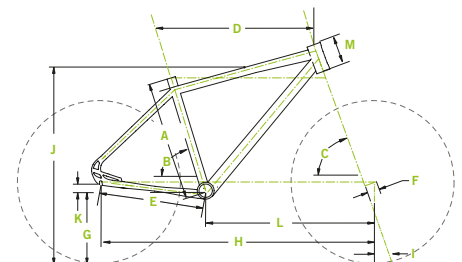

URBAN

E-SERIES

E-SERIES WOMENS

SPECIFICATIONS	50	55	60	45	50	55
A SEAT TUBE LENGTH	50	55	60	45	50	55
B TOP TUBE HORIZONTAL	570	58.4	60.8	56.2	56.8	56
C TOP TUBE ACTUAL	54.7	55.9	58.8	--	--	--
D HEAD TUBE ANGLE	71°	71.5°	72°	71°	71°	71°
E SEAT TUBE ANGLE	74°	73.5°	73°	75°	75°	75°
F STANDOVER	4.5	82.9	85.4	41.1	41.1	41.1
G HEAD TUBE LENGTH	11.4	11.4	11.4	11.4	11.4	11.4
H WHEELBASE	109.3	109.6	111	109.9	110.7	112.1
I FRONT CENTER	63.1	63.4	64.9	63.5	64.4	65.7
J CHAIN STAY LENGTH	47	47	47	47	47	47
K BOTTOM BRACKET DROP	67	67	67	58	58	58
L BOTTOM BRACKET HEIGHT	28.3	28.3	28.3	29.2	29.2	29.2
M FORK RAKE	45	45	45	45	45	45
N TRAIL	72.9	69.6	66.4	72.9	72.9	72.9
O REACH	36.8	37.8	38.2	38.3	39.4	39.9

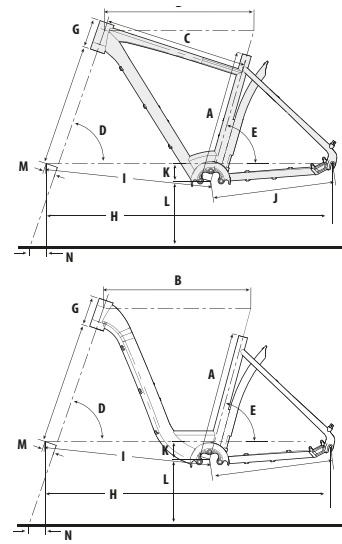

WOMEN'S

SUPERSIX EVO

CAAD10

SPECIFICATIONS	44	48	51	54	56	48	51	54	56
A HORIZONTAL TOP TUBE LENGTH (CM)	49.4	50.9	52.3	53.9	55.3	50	51.5	52	53.5
B MEASURED SIZE (CM)*	40	43	46	47	50	42	46	49	52
C SEAT TUBE ANGLE (DEGREES)	75°	74.6°	74.2°	73.8°	73.4°	76	74.5	74.5	73.5
D HEAD TUBE ANGLE (DEGREES)	70°	70.8°	71.5°	72.2°	72.9°	70.5	72	72.5	73
E CHAINSTAY LENGTH (CM)	40.5	40.5	40.5	40.5	40.5	40.5	40.5	40.5	40.5
F FORK RAKE (CM)	5	5	5	4.5	4.5	5	5	5	4.5
G BOTTOM BRACKET HEIGHT (CM)	26.5	26.5	26.5	26.8	26.8	26.5	26.5	26.5	26.5
H WHEELBASE (CM)	96.7	97.3	97.8	97.9	98.4	96.3	95.9	96.1	96.3
I TRAIL (CM)	7	6.5	6.1	6.2	5.8	71.6	6.2	59.1	56
J STANDOVER (CM)	70.5	72.8	75.0	77.0	78.8	71.3	74	76.1	78.5
K BOTTOM BRACKET DROP (CM)	7.2	7.2	7.2	6.9	6.9	7.2	7.2	7.2	7.2
L FRONT CENTER DISTANCE (CM)	56.9	57.4	58	58	58.5	56.9	56.5	56.7	56.9
M HEAD TUBE LENGTH (CM)	10.5	11.2	13.4	15	16.5	10.5	11	13	15
N STACK (CM)	50.1	51.8	53.5	55.2	56.9	50.3	51.7	53.4	55.7
O REACH (CM)	36	36.6	37.2	37.8	38.4	36.5	36.8	36.8	37

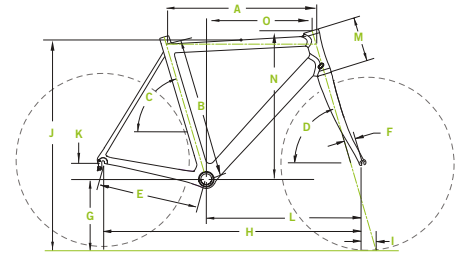

SYNAPSE CARBON

SYNAPSE ALLOY

SPECIFICATIONS	44	48	51	54	44	48	51	54	56	47	51	54
WHEEL SIZE	700C	700C	700C	700C	700C	700C	700C	700C	700C	650C	700C	700C
A HORIZONTAL TOP TUBE LENGTH (CM)	50	51	52.5	53.5	50	51	52	53	54.5	49.5	50.5	53.5
B MEASURED SIZE (CM)*	38	42	45	49	40	44	47	50	52	46	50	51.5
C SEAT TUBE ANGLE (DEGREES)	76°	74.5°	74°	74°	76°	76°	74°	74°	73.5°	VARIABLE	VARIABLE	VARIABLE
D HEAD TUBE ANGLE (DEGREES)	70.5°	71°	72°	72.5°	70.5°	70.5	72°	72°	72.5°	71°	71.5°	71.5°
E CHAIN STAY LENGTH (CM)	41	41	41	41	41.5	41.5	41.5	41.5	41.5	37	40	40
F FORK RAKE (CM)	5.0	5.0	5.0	5.0	50.0	50.0	50.0	50.0	50.0	4	4.5	4.5
G BOTTOM BRACKET HEIGHT (CM)	26.5	26.5	26.5	26.5	26.5	26.5	26.5	29.5	29.5	26.5	26.5	26.5
H WHEELBASE (CM)	97.2	97.0	97.5	98.2	97.7	97.9	98.0	99.3	98.9	92	95.4	98.5
I TRAIL (CM)	6.6	6.3	5.7	5.4	6.6	6.6	5.7	5.7	5.4	6.6	6.5	6.5
J STANDOVER AT TOP TUBE MIDPOINT (CM)	69.8	72.1	74.4	77.0	71.6	73.2	75.6	77.0	79.0	71.9	74.9	76.4
K BOTTOM BRACKET DROP (CM)	7.2	7.2	7.2	7.2	72.0	72.0	72.0	69.0	69.0	5	7.2	7.2
L FRONT CENTER DISTANCE (CM)	57.3	57.1	57.6	58.3	57.3	57.5	57.6	58.8	58.4	55.6	56.5	59.6
M HEAD TUBE LENGTH (CM)	12.5	13	14.5	16	13	13	14.5	16	18.5	10.3	9	10.5
N STACK (CM)	52.4	53.0	54.8	56.4	52.9	52.9	54.8	56.9	59.2	47.8	49.4	50.9
O REACH (CM)	35.3	35.5	36.3	37.1	35.4	36.8	36.4	36.4	36.8	36.5	37.1	39.8

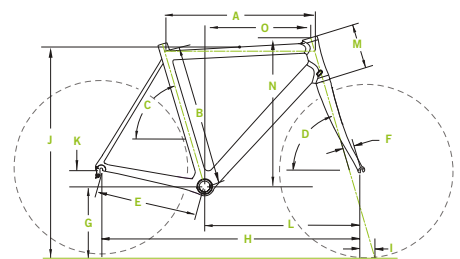

WOMEN'S

SCARLET

SPECIFICATIONS	P	S	M
A SEAT TUBE LENGTH (CM/IN)	40.7/16.0	43.2/17.0	45.7/18.0
B TOP TUBE HORIZONTAL (CM/IN)	54.0/21.3	55.6/21.9	57.2/22.5
C TOP TUBE ACTUAL (CM/IN)	52.1/20.5	53.4/21.0	54.9/21.6
D HEAD TUBE ANGLE (DEGREES)	67.6°	67.7°	67.8°
E SEAT TUBE ANGLE EFFECTIVE (DEGREES)	73.7°	73.6°	73.6°
F STANDOVER (CM/IN)	71.8/28.3	72.4/28.5	73.0/28.7
G HEAD TUBE LENGTH (CM/IN)	13.4/5.3	13.4/5.3	13.4/5.3
H WHEELBASE (CM/IN)	108.6/42.8	110.0/43.3	113.1/44.5
I FRONT CENTER (CM/IN)	65.8/25.9	67.2/26.5	70.3/27.7
J CHAIN STAY LENGTH (CM/IN)	42.8/16.9	42.8/16.9	42.8/16.9
K BOTTOM BRACKET DROP (CM/IN)	1.2/0.5	1.2/0.5	1.2/0.5
L BOTTOM BRACKET HEIGHT (CM/IN)	35.0/13.8	35.0/13.8	35.0/13.8
M FORK RAKE (CM/IN)	4.0/1.6	4.0/1.6	4.0/1.6
N TRAIL (CM/IN)	9.6/3.8	9.5/3.8	9.5/3.8

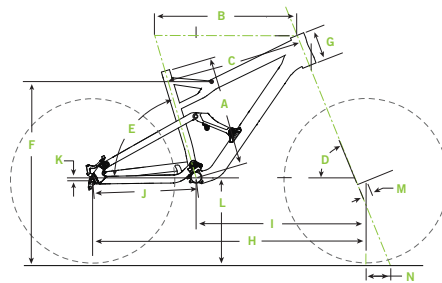

LEXI

SPECIFICATIONS	P	S	M
A SEAT TUBE LENGTH (CM/IN)	40.6/16.0	43.2/17.0	45.7/18.0
B TOP TUBE HORIZONTAL (CM/IN)	53.0/20.9	56.0/22.0	57.5/22.6
C TOP TUBE ACTUAL (CM/IN)	50.8/20.0	53.5/21.1	55.0/21.7
D HEAD TUBE ANGLE (DEGREES)	68.5°	69.0°	69.0°
E SEAT TUBE ANGLE EFFECTIVE (DEGREES)	73.5°	73.5°	73.5°
F STANDOVER (CM/IN)	72.9/28.7	73.1/28.8	75.9/29.9
G HEAD TUBE LENGTH (CM/IN)	13.4/5.3	13.4/5.3	13.4/5.3
H WHEELBASE (CM/IN)	105.2/41.4	107.6/42.4	109.1/43.0
I FRONT CENTER (CM/IN)	62.8/24.7	65.2/25.7	66.6/26.2
J CHAIN STAY LENGTH (CM/IN)	42.5/16.7	42.5/16.7	42.5/16.7
K BOTTOM BRACKET DROP (CM/IN)	0.0/0.0	0.0/0.0	0.0/0.0
L BOTTOM BRACKET HEIGHT (CM/IN)	33.0/13.0	33.0/13.0	33.0/13.0
M FORK RAKE (CM/IN)	4.5/1.8	4.5/1.8	4.5/1.8
N TRAIL (CM/IN)	8.2/3.2	7.8/3.1	7.8/3.1

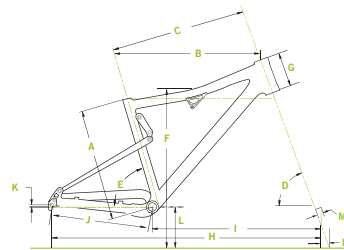

TRAIL SL 29ER WOMEN'S

SPECIFICATIONS	S	M	L
A SEAT TUBE LENGTH (CM/IN)	35.0/13.8	41.5/16.3	45.0/17.7
B TOP TUBE HORIZONTAL (CM/IN)	52.2/20.6	57.0/22.4	58.9/23.2
C TOP TUBE ACTUAL (CM/IN)	54.4/21.4	58.2/22.9	60.0/23.6
D HEAD TUBE ANGLE (DEGREES)	70.5°	71.0°	71.0°
E SEAT TUBE ANGLE (DEGREES)	73.5°	73.5°	73.0°
F STANDOVER - 7.5 CM IN FRONT OF BB(CM/IN)	68.0/26.8	68.7/27.0	71.6/28.2
G HEAD TUBE LENGTH (CM/IN)	9.0/3.5	10.2/4.0	11.4/4.5
H WHEELBASE (CM/IN)	108.4/41.8	106.4/41.9	107.8/42.4
I FRONT CENTER (CM/IN)	61.3/24.1	62.8/24.7	64.3/25.3
J CHAIN STAY LENGTH (CM/IN)	44.4/17.5	44.4/17.5	44.4/17.5
K BOTTOM BRACKET DROP (CM/IN)	6.5/2.6	6.5/2.6	6.5/2.6
L BOTTOM BRACKET HEIGHT (CM/IN)	30.5/12.0	30.5/12.0	30.5/12.0
M FORK RAKE (CM/IN)	4.5/1.8	4.5/1.8	4.5/1.8
N TRAIL (CM/IN)	8.3/3.3	8.0/3.1	8.0/3.1
O STACK (CM/IN)	59.6/23.5	61.0/24.0	62.2/24.5
P REACH (CM/IN)	37.3/14.7	38.9/15.3	40.0/15.7

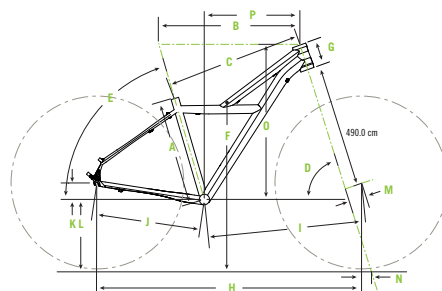

TRAIL SL WOMEN'S

SPECIFICATIONS	P	S	M	L
A SEAT TUBE LENGTH (CM/IN)	35.0/13.8	38.0/15.0	41.5/16.3	45.0/17.7
B TOP TUBE HORIZONTAL (CM/IN)	52.2/20.6	55.0/21.7	57.0/22.4	58.9/23.2
C TOP TUBE ACTUAL (CM/IN)	54.4/21.4	56.4/22.2	58.2/22.9	60.0/23.6
D HEAD TUBE ANGLE (DEGREES)	70.0°	70.0°	70.0°	70.0°
E SEAT TUBE ANGLE (DEGREES)	75.0°	73.5°	73.5°	73.5°
F STANDOVER - 7.5 CM IN FRONT OF BB(CM/IN)	69.5/27.4	71.6/28.2	74.2/29.2	76.7/30.2
G HEAD TUBE LENGTH (CM/IN)	9.0/3.5	9.0/3.5	10.2/4.0	11.4/4.5
H WHEELBASE (CM/IN)	103.4/40.7	104.6/41.2	106.7/42.0	108.7/42.8
I FRONT CENTER (CM/IN)	61.2/24.1	62.4/24.6	64.5/25.4	66.5/26.2
J CHAIN STAY LENGTH (CM/IN)	42.4/16.7	42.4/16.7	42.4/16.7	42.4/16.7
K BOTTOM BRACKET DROP (CM/IN)	3.0/1.2	3.0/1.2	3.0/1.2	3.0/1.2
L BOTTOM BRACKET HEIGHT (CM/IN)	31.0/12.2	31.0/12.2	31.0/12.2	31.0/12.2
M FORK RAKE (CM/IN)	4.5/1.8	4.5/1.8	4.5/1.8	4.5/1.8
N TRAIL (CM/IN)	7.6/3.0	7.6/3.0	7.6/3.0	7.6/3.0
O STACK (CM/IN)	56.4/22.2	56.4/22.2	57.6/22.7	58.8/23.1
P REACH (CM/IN)	37.1/14.6	38.2/15.0	39.9/15.7	41.5/16.3

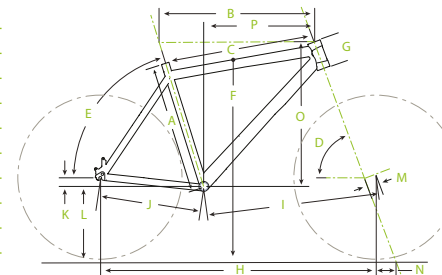

REGISTERED TRADEMARKS® OF CYCLING SPORTS GROUP, INC.:

Cannondale, the Cannondale "C" logo, the Cannondale train station logo, Daytripper, Claymore, CSGXCHANGE, Fatty, Gemini, Jekyll, Lefty, Perp, Prophet, Scalpel, Slice, Velopods, Synapse, System6, Systemsix, Hooligan, Felicity, SIMON, ELO, Felicity, Scarlet, SuperSix.

TRADEMARKS™ OF CYCLING SPORTS GROUP, INC.:

BB30, CAAD (Cannondale Advanced Aluminum Design), HeadShok, Hi-MOD, Hollowgram, "Fit, Features and Fashion", PowerPyramid, Quick, Q-Lab, RZ, SAVE, Si, System Integration, BallisTec Carbon, SmartFormed Alloy, ECS-TC (Enhanced Center-Stiffness, Torsion Control) System, Zero Pivot, Lexi, Althea, Trigger, Narrow is Aero, Durathon and PopTop.

Liquigas is a registered trademark and used with their permission. FOX, FOX Racing Shox and Dyad RT2 are registered trademarks of FOX Factory Inc. and are used with their permission. Solo Air, RockShok, XLoc are registered trademarks of SRAM and are used with their permission. X-12 is a trademark of Syntace GmbH and is used with their permission. EVO is a trademark of Aprebic Industry Co. Ltd. and used under license.

Cannondale supports pro teams. We are grateful for the past and/or current support of: FSA, Mavic, SRAM (including Avid, Rockshox, Zipp), Lotto, Rudy Project, MeT, Nalini, Sidi, fi'zi:k, SRM, Speedplay, Schwalbe, Elite, Sci Con, Crankbrothers, Avid, Cyclocrossworld.com, Zipp, Grip Grab, Campagnolo, Shimano. Branding from these partners, based on sponsor agreements may be seen on photos in this catalog. Individual athletes may display other sponsored brands, based upon their own sponsorship agreements with those brands.

WWW.CANNONDALE.COM

Please visit cannondale.com to learn more about Cannondale and the 2013 bikes! Specifications subject to change without notice.

Please refer to www.cannondale.com for the most recent specifications.

NO WEIGHTS? Don't believe the hype. Scales differ, and marketing departments have been known to fib. The best way to compare bike weights is to head to your local bike shop. Grab two comparably spec'd and built bikes, and ask the proprietor for a scale. Hang 'em high, and see who's the lightest.

Bicycling has risks of serious injury or death that cannot be completely avoided. Risk can be minimized by: Reading and following all warnings and instructions in owner's manuals, owner's manual supplements, always wearing a helmet, practice and step-by-step learning, riding in control and within your capabilities. Catalog text and descriptions are marketing materials, not instructions or guidelines for use! Visit <http://www.cannondale.com/bikes/tech/safety> for warnings, technical documents, and safety guidelines.

Warning: Reflectors are not a substitute for proper lights. It is your responsibility to equip your bicycle with all state and locally mandated lights. Riding at dawn, at dusk, at night or at other times of poor visibility without a bicycle lighting system which meets local and state laws and without reflectors is dangerous and may result in serious injury or death.

If you ride your bike before dawn or after dusk, your bicycle must be equipped with lights so that you can see the road and avoid road hazards, and so that others can see you. Traffic laws treat bicycles like any other vehicle. That means you must have a white front and a red rear light operating if you are riding after dusk. Your bike dealer can recommend a battery or generator powered lighting system appropriate to your needs.

Cannondale also strongly urges you to use a flashing light or strobe. All of us at Cannondale who ride at night or in conditions of lower visibility use flashers. They can save your life

Please note: Despite our nagging, members of the Liquigas pro road racing team (and other professional sponsored teams) may appear or race without helmets. We don't think it's a good idea, but they are experienced, professional cyclists and they know the risks. They are also adults, so we respect their right to choose. Despite the intransigence of any teams, we strongly advocate the use of helmets on every ride. Wearing a helmet is perhaps your single best defense against a major medical catastrophe while riding, so buckle up!

Warning: Free riding is inherently dangerous. Read Free ride Warning at <http://www.cannondale.com/bikes/tech/safety.html>

CANNONDALE AUTHORIZED DISTRIBUTORS

The following lists are subject to change without notice.

BELARUS: Sinij Medved, Osipenko 2, 92, 220053, Minsk, tel: +375 29 621 86 07, email: contact@velozona.by

BULGARIA: KCP Group, 50 Sfakion STR 12131, Greece, tel: +30 210 5317960, fax: +30 210 5317961, email: info@kcp.gr, ht tp://www.kcp.gr

CROATIA: Keindl Sport, Reljkoviceva 2, 10000 Zagreb, tel: +385 1 3711 711, fax: +385 13708324, email: info@keindl-sport.com, http://www.keindl-sport.com

CZECH REPUBLIC: Aspire Sports s.r.o., Karasek 11, Brno, 62100, tel: +420 532 199 540, fax: +420 532 199 554, email: Marian.Materna@aspire.cz, http://www.aspire.cz

CYPRUS: KCP Group, 50 Sfakion STR 12131, Greece, tel: +30 210 5317960, fax: +30 210 5317961, email: info@kcp.gr, http://www.kcp.gr

ESTONIA: Extreme Sport AS, Merivälja tee 1, 11911 Tallinn, tel: +372 650 8686, fax: +372 650 8687, email: info@extreme.ee, http://www.extreme.ee

GREECE: KCP Group, 50 Sfakion STR 12131, Greece, tel: +30 210 5317960, fax: +30 210 5317961, email: info@kcp.gr, http://www.kcp.gr

HUNGARY: Mali Bicycle Technology, Szinesfem u. 22-24, 1211 Budapest, tel: +36-1420-5032, fax: +36-142-0532, email: mali@mali.hu

ICELAND: GA Petursson Ltd., Faxafen 7, 108 Reykjavik, Box 8176, tel: +354 5200 200, fax: +354 5200 301, email: mogens@gap.is, http://www.gap.is

KAZAKHSTAN: Limpopo Outdoor, 534 Seifallin Str., Almaty, 050022, tel: 73272617061, fax: 73272617265, email: limpop@nursat.kz, http://www.limpopo.kz

LATVIA: IKS SPORTS, Dzutas str 8, Riga, Lv1006, www.xsports.lv, info@xsports.lv, tel. 0037167545537, fax 0037167545523

LITHUANIA: EGMINDA UAB, Ukmerges g. 283A, LT06313 Vilnius, Tel (8-5) 2323080, p.dainius@umaras.com

MALTA: Pedal Power, 56 Triq Is-Stazzjon, B'Kara BKR 12, Malta, tel: +356 212 27265, fax: +356 212 227265, email: musco@global.net.mt, http://www.pedpowermalta.com

POLAND: PGR Sp. Z.O.O., ul Rydygiera 8/bud.20B, lok 227, Warszawa 01-793, tel: +48 22 6699690, email: biuro@grupapgr.pl, http://www.grupapgr.pl

ROMANIA: Maros Bike, Aurel Vlaicu no. 120, Cluj Napoca, tel: +40 2644 10779, email: office@marosport.ro, http://www.marosbike.ro

RUSSIA: SLOPESTYLE, 15, Proektnaya Street, Gagariń's Microdistrict, Balashikha, Moscow Region, 143900, tel: 007 495 9684908, email: info@slopestyle.com, website: http://slopestyle.ru

SERBIA: Planet Bike Co. doo, Milosa Obilica 9-11, 37000 Krusevac, tel: +381 37 420000, fax: +381 37 420011, email: office@planetbike.rs, http://www.planetbike.rs

SLOVENIA: Sport trade 2000 d.o.o., Celovska 280, Ljubljana, 1000, tel: +386-15104940, fax: +386-151 82163, email: sandi.gabrovsek@siol.net, http://www.funssports.si

SLOVAKIA: Aspire Sports s.r.o., Karasek 11, Brno, 62100, tel: +420 532 199 540, fax: +420 532 199 554, email: Marian.Materna@aspire.cz, http://www.aspire.cz

TURKEY: Delta Bisiklet HQ, BosnaHersek Cd. 20/D, 06510, Emek Ankara, Turkey, tel: +90312 2236027, fax: +90312 223492, email: info@deltabisiklet.com, http://www.deltabisiklet.com

UKRAINE: Veloplaneta, Enakievskaya 2E, 61158 Khar'kov, Ukraine, tel: +380504023705, fax: +38057 7544 981, email: veloplaneta@gmail.com, www.veloplaneta.com.ua

EUROPEAN DISTRIBUTORS: distributors@cannondale.com, tel: 0041 61 4879387, fax: 0041 61 4879385 0031-541-573587, fax: 0031-541-514240

EUROPEAN TOURISM/RESORTS: distributors@cannondale.com, tel: 0041 61 4879387, fax: 0041 61 4879385, 0031-541-573587, fax: 0031-541-514240

EUROPEAN APPAREL/ACCESSORIES DEALERS: distributors@cannondale.com, tel: 0041 61 4879387, fax: 0041 61 4879385

INTERNATIONAL SALES: 172 Friendship Village RD, Bedford, PA 15522 USA, tel: 814-623-4391, fax: 814-623-2107, email: international@cannondale.com

ARGENTINA: Lauro Competicion, Avda. San Pedrito 577, Buenos Aires, Argentina 01406, tel: 4613-8859, fax: 54-11-4612-8805, email: laurocompeticion@hotmail.com, http://www.cannondaleargentina.com

ARGENTINA: 10X SRL, Mexico 3662 PB 35, Buenos Aires Argentina 1223, tel: 54-11-49316003

BERMUDA: The New Winners Edge, 34 Church Street, Hamilton HM11, Bermuda, tel: 441-295-6012, fax: 411-292-1904

BOLIVIA: Visal Import & Export, Avenida Banzer #656, Santa Cruz, Bolivia, tel: (591-3) 341 4141, fax: (591-3) 341 4600

BORNEO: Cannasia, 101 Frankel Ave., Singapore tel/fax: 65-6441-4772, http://www.cannasia.com

BRAZIL: Cannondale Brasil, Av. Prof. Sylia Matos, 370, CEP 04182-010 Sao Paulo Brazil, tel: 2264-2167/2264-2143, http://www.cannondale.com.br

BRUNEI: Cannasia, 101 Frankel Ave., Singapore, 458224, tel: 65-6441-4772, email: cannasia@mbox5.singnet.com.sg, http://www.cannasia.com

CAMBODIA: Flying Bike Shop, No. 8 Street 114, Phnom Pehn Cambodia 12000, tel: 855-128-06035, email: flyingbikes@online.com.kh

CHILE: Inversiones Intercycles Ltda., Av. Neuva Las Condes, 12.270 #101, Santiago, Chile, South America, tel: 562-215-3470, fax: 562-217-3167, email: cycles@cannondale.cl

COSTA RICA: Xcesso S.A., San José, Costa Rica, tel: 506-2290-5696, fax: 506-2290-3412, email: xcesso@racsa.co.cr

DOMINICAN REPUBLIC: Aro & Pedal, 27 de Febrero #112, Santo Domingo, Dominican Republic, tel: (809) 686-5861, fax: (809) 687-6548, email: aro.pedal@codetel.net.do

ECUADOR: BikeLife, Shirys N41-206 e Isla Floreana, Quito Ecuador tel: 593-99-217050, fax: 593-22-440312

EL SALVADOR: Grupo Extremo, Blvd Santa Elena Atrium Plata 5y6 Antiquo Cuscattan San Salvador, El Salvador, tel: 502-228-99636

GUAM: Hornet Bicycles, PO Box 8290, Tamuning, Guam 96931, tel: 671-646-9191, fax: 671-646-1194, email: hikko@guamcell.net

GUATEMALA: Bike Center, S. A., 20 Calle 24-67 Zona 10, Paris Plaza, Local 2-3, Guatemala City Guatemala, tel: 502-333-4388, fax: 502-333-7394, email: bikecenter@intelnet.net

HONDURAS: Hondubikes, Col.Humuya Av.Sabana Tegucigalpa, Honduras, tel/fax: 504-239-2192

HONG KONG: Flying Ball Bicycle, Unit G58 Lai Sun Commercial Center, 680 Cheung Sha Wan Road, Kowloon, Hong Kong, tel: 852-238-13661, fax: 852-239-74406, http://www.flyingball.com

INDIA: Tube Investments of India, PO Box 5, MTH Rd Ambattur, Chennai 60053, India, tel: 914 428 553492, fax: 914 -428-553757

INDONESIA: Cannasia Pte. Ltd., 101 Frankel Ave., Singapore, 458224, tel: 65-6441-4772, email: cannasia@mbox5.singnet.com.sg, http://www.cannasia.com

ISRAEL: O.R Cycling Ltd., 6296,Netanya 42160, tel: +972-(0)-891-7395, email: info@cannondale.co.il, http://www.cannondale.co.il

JAMAICA: Hi Tech Industries LTD., 8 Dumfries Road Kingston 10 Jamaica W. Indies, tel: 876 855 8888 , fax: 876 978 7414

KOREA: Sanbada Sports, 1F Gungdo Building 278-19, NonHyun-Dong, Seoul, Korea, tel: 822-543-6390, fax: 822-3442-6391, email: sanbada1@unitel.co.kr

MALAYSIA: Cannasia Pte. Ltd., 101 Frankel Avenue, Singapore, 458224, tel: 65-6441-4772, cannasia@singnet.com.sg, http://www.cannasia.com

MAURITIUS: Emcar Ltd, Old Moka Road , Bell Village, Republic of Mauritius, tel: 230-208-6335, fax: (230) 212-5952

MEXICO: Bicicletas Mercurio S.A. DE C.V., Carretera Central 422 Zona Industrial, San Luis Potosi, Mexico 78090, tel: 5201-444-144-2403

NETHERLAND ANTILLES: Tri-Sport N.V., #14B Airport Blvd Simpsonbay, St. Maarten, Netherlands Antilles, tel: (599)545-4385, fax: (599)545-4384, http://www.trisport@sintmaarten.net

NEW CALEDONIA: Royal Motors SA., 9, route de la Baie des Dames B.P. 2548, Nouméa, New-Caledonia, 98846, tel: 687 285 912, fax: 687 286 320, http://www.r.motors@groupedang.nc

NEW ZEALAND: WH Worrall, 43 Felix Street, Penrose, Auckland, New Zealand; tel: (649) 636 0641; email: office@worrall.co.nz

PANAMA: Latin Bikes S.A., Calle 50 Final y Via Cincuentenario, Edificio Adelina, Local #1, San Francisco, Panama, tel: (507) 60902002

PERU: Inversiones Intercycles Ltda., Av. Nueva Las Condes, 12.270 #101 Santiago, Chile, tel: 562-215-3470, fax: 562-217-3167, email: cycles@cannondale.cl

PUERTO RICO: Bikeworks, 1500 Bori St Suite 4, San Juan Puerto Rico 00927, tel: 787-763-4369

PHILIPPINES: Newton Multi-Sales, 689-D Del monte Ave., SFDM Quezon City, Metro Manila, Philippines, 1100, tel: (0632)3725127-28 & 3717231, 5595301, 5595311, fax: (0632) 3735439, email: bike_newton@yahoo.com

PUERTO RICO: TL Bicycle Distributor Inc, Jose A. Lugo, Edif. Mar de Isla Verde Apt 10-Q, San Juan Puerto Rico, 00979, tel: 787 613 1040,

SINGAPORE: Cannasia Pte. Ltd., 101 Frankel Avenue, Singapore 458224, tel: 65-6441-4772, Cannasia@singnet.com.sg, http://www.cannasia.com

SOUTH AFRICA: Omnico (PTY) Ltd, Unit 1 B Kimbult Industrial Park, 8 Zeiss Road, Honeydew, South Africa, 2170, Lionel Dippenaar, tel: +27(0)117943808, Mobile : +27(0)832587777, lionel@omnico.co.za, http://www.omnico.co.za

TAIWAN: Three Peaks Bicycle Company, No. 222 Jin-Xian 8th Rd, Taichung Taiwan, tel: 886-424-368842, http://www.threepeaks.com.tw

THAILAND: Cychoholic 45/39 Soi Atthakrawee 1, Sukhumvit 26 Road (Soi Aere) Bangkok, Thailand 10110 tel: +66815678886 email: thaicann@cannasia.com, http://www.thaicannasia.com

TRINIDAD: Motorcycles Etc., 89 Eastern Main Road, Barataria, Trinidad and Tobago, tel: 868-675-2453, fax: 868-675-3816, email: larrya@wow.net

TRINIDAD: Sports & Games 47 Tissue Drive Trincity, Trinidad, tel: 868-640-2507, fax: 868-640-0505

UNITED ARAB EMIRATES: Prozone P.O. Box # 123500 Dubai (United Arab Emirates) tel: +9714 33-88644, fax: +009714 3385552, email: Info@prozoneld.com, http://www.dubaicycles.com

URUGUAY: Motociclo SA, AV Sayago 1385-CP 12400, Montevideo, Uruguay, tel: 5982 354 20 80

VENEZUELA: Bici Bikes, 2A AV, Ed. Artelito local 5 (WINDCTR) Los Palos Grandes, Caracas, Venezuela 1041, tel: 58-212-286-0285; fax: 58-212-283-7466

VENEZUELA: Puff, CA, Av. Jovito Villaiba, Am Centro Empressarial, Piso 1, OFC. 1-2. Porlamar Margarita Venezuela 6301, tel: 582-869-626155, fax: 584-148-672749, email: jorgegraublanc@gmail.com

VIETNAM: Jett Cycles, 348-350 Tran Phu, Ho chin Minh Vietnam 12345, tel: 848-385-39018, email: daniel@jett-cycles.com

WORLD WIDE MILITARY SALES: tel: 814 623 4391; fax: 814 623 2107, international@cannondale.com

WORLD WIDE TOURISM & RESORTS: tel: 814 623 4391; fax: 814 623 2107, international@cannondale.com

CANNONDALE CORPORATE OFFICES

CANNONDALE AMERICAS

Cycling Sports Group, Inc.
172 Friendship Road,
Bedford, Pennsylvania, 15522-6600,
USA
Tel: 1-800-BIKE-USA
Fax: 814-623-6173
Email: custserv@
cyclingsportsgroup.com

CANNONDALE EUROPE

Cycling Sports Group Europe, B.V.
mail: Postbus 5100
visits: Hanzeplein 27
7570 GC, Oldenzaal, Netherlands
Tel: +41 61.4879380
Fax: 31-5415-14240
Email: servicedeskurop@
cyclingsportsgroup.com

CANNONDALE UK

Cycling Sports Group
Vantage Way, The Fulcrum, Poole,
Dorset, BH12 4NU
Tel: +44 (0)1202 732288
Fax: +44 (0)1202 723366
Email: sales@
cyclingsportsgroup.co.uk

CANNONDALE AUSTRALIA

Cycling Sports Group
Unit 8, 31-41 Bridge Road
Stanmore NSW 2048
Tel: +61 (0)2 8595 4444
Fax: +61 (0)2 8595 4499
Email: askus@
cyclingsportsgroup.com.au

CANNONDALE JAPAN

Namba Sumiso Building 9F,
4-19, Minami Horie 1-chome,
Nishi-ku, Osaka 550-0015,
Japan
Tel: 06-6110-9390
Fax: 06-6110-9361
Email: cjcustserv@
cannondale.com

CANNONDALE CHINA

Cycling Sports Group China Co., Ltd.
Room 208, No. 3203, Minhang District
Hongmei Road, Shanghai 201103,
China
Tel: 86 21 6446 8999
Fax: 86 21 6465 6570
Email: csg@dorelchina.com



CANNONDALE EUROPE
© 2012 CANNONDALE BICYCLE CORPORATION
WWW.CANNONDALE.COM

129135